

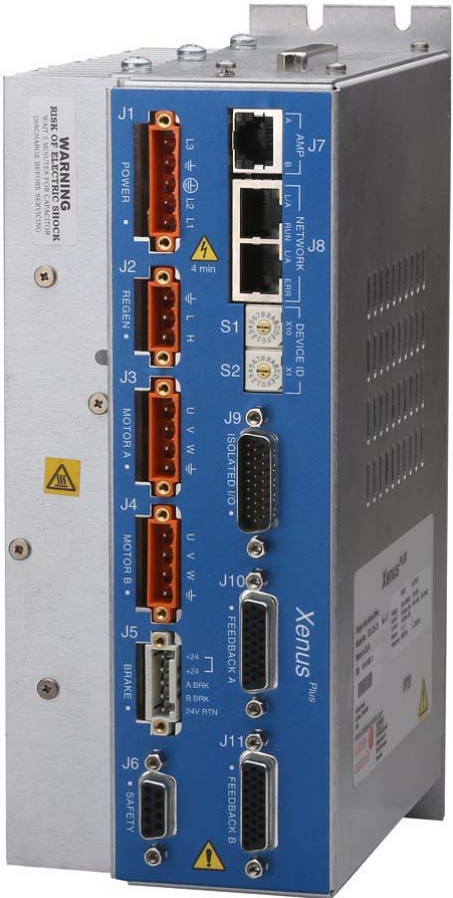

# Xenus Plus™

## User Guide



P/N 16-01344  
Revision 01  
April 2, 2015

This page for notes

TABLE OF CONTENTS

**About This Manual** ..... 5

**1: Introduction** ..... 10

    1.1: Xenus Plus Family Overview ..... 11

    1.2: CME 2 ..... 12

    1.3: CML/CMO ..... 13

    1.4: Copley Virtual Machine (CVM) ..... 13

    1.5: Indexer 2 ..... 13

    1.6: CPL ..... 13

**2: Operational Theory** ..... 14

    2.1: Drive Power Architecture ..... 15

    2.2: Operating Modes ..... 17

    2.3: Input Command Types ..... 28

    2.4: Communication ..... 33

    2.5: Status Indicators ..... 38

    2.6: Protection ..... 50

    2.7: Position and Velocity Errors ..... 52

    2.8: Inputs XEL/XPL/XML ..... 55

    2.9: Inputs XE2/XP2/XM2/800-1818/800-1819 ..... 56

    2.10: Outputs, XEL/XPL/XML ..... 58

    2.11: Outputs, XE2/XP2/XM2/800-1818/800-1819 ..... 58

    2.12: Brake Operation ..... 58

    2.13: Regen Resistor Theory ..... 61

**3: Specifications** ..... 64

    3.1: Agency Approvals ..... 65

    3.2: Power Input ..... 65

    3.3: Power Output ..... 66

    3.4: Control Loops ..... 67

    3.5: Regen Circuit Output (External Regen Resistor) ..... 67

    3.6: Regen Circuit Output (Internal Regen Resistor) ..... 67

    3.7: Digital Command Inputs ..... 68

    3.8: Analog Inputs ..... 68

    3.9: Digital Inputs ..... 69

    3.10: Analog Outputs ..... 70

    3.11: Digital Outputs ..... 70

    3.12: Encoder Power Outputs ..... 71

    3.13: Primary Encoder Inputs ..... 71

    3.14: Analog Encoder Inputs ..... 72

    3.15: Hall Switch Inputs ..... 73

    3.16: Resolver Interface ..... 74

    3.17: Multi-Mode Port ..... 75

    3.18: Serial Interface ..... 76

    3.19: Network Interfaces ..... 77

    3.20: Status Indicators ..... 78

    3.21: Fault Levels ..... 78

    3.22: Power Dissipation ..... 79

    3.23: Thermal Impedance ..... 79

    3.24: Mechanical and Environmental ..... 80

    3.25: Dimensions ..... 81

**4: Wiring** ..... 84

    4.1: General Wiring Instructions ..... 85

    4.2: AC Mains (J1) ..... 88

    4.3: Motor(s) ..... 91

    4.4: Regen Resistor (Optional) ..... 93

    4.5: Logic Supply / Brake ..... 96

    4.6: Ferrules – XE2/XP2/XM2/800-1818/800-1819 ..... 98

    4.7: Safe Torque Off ..... 99

    4.8: RS-232 Serial Communications ..... 103

    4.9: Network Ports ..... 104

    4.10: Control I/O ..... 107

    4.11: Motor Feedback ..... 123

**A: Regen Resistor Sizing and Configuration** ..... 132

    A.1: Sizing a Regen Resistor ..... 133

**B: I<sup>2</sup>T Time Limit Algorithm** ..... 137

    B.1: I<sup>2</sup>T Algorithm ..... 138

**C: Thermal Considerations** ..... 141

    C.1: Operating Temperature and Cooling Configurations ..... 142

    C.2: Heatsink Mounting Instructions (XEL/XPL/XML) ..... 145

**D: Xenus Plus Filter** ..... 146

    D.1: Overview ..... 147

D.2: XTL-FA-01 Edge Filter Wiring ..... 150

**E: Connecting XPL/XP2 for Serial Control..... 154**

E.1: Single-Axis and Multi-Drop..... 155

**F: Ordering Guide and Accessories..... 156**

F.1: Drive Model Numbers ..... 157

F.2: Accessory Model Numbers..... 160

F.3: Heatsink Kits..... 161

F.4: Regen Resistor Assemblies ..... 162

F.5: Edge Filter ..... 162

F.6: Order Example ..... 162

F.7: Copley Standard Regen Resistor Specifications..... 163

# ABOUT THIS MANUAL

## Title, Number, Revision

Title	The Xenus Plus User Guide
Document Number	16-01344
Current Revision	01

## Revision History

Revision	Date	ECO	Comments
AA	December 30, 2014	ECO-056871	Initial Release. Originated from 16-01018 Rev 07
00	March 9, 2015	ECO-056484	Updated PE symbols and clarified mandatory use of line filters.
01	April 2, 2015	ECO-057985	OVC II Mains Requirement and full address for Mfr & EU Rep. Add model 800-1818

## EC Declaration of Conformity

The products covered by this user guide comply with the applicable EC Directives including 2004/108/EC (EMC Directive) and 2006/95/EC (Low Voltage Directive). Complete EC Declarations of Conformity are available on the internet at [www.copleycontrols.com](http://www.copleycontrols.com).

**Name and Address of the Manufacturer:**  
 Analogic Corporation d/b/a Copley Controls  
 20 Dan Road  
 Canton, MA 02021  
 USA

**Name and Address of the authorized representative:**  
 BK Medical ApS  
 Mileparken 34, DK-2730  
 Herlev  
 Denmark

## Overview and Scope

This manual describes the operation and installation of the XEL, XE2, XPL, XP2, XML, XM2, 800-1818 and 800-1819 drives manufactured by Copley Controls. All Xenus plus products have serial numbers that incorporate the week and year of production into the first 4 digits (WWYY) of the serial number.

**EC Declaration of Conformity**

The complete EC Declarations of Conformity for all products are available on the internet at [www.copleycontrols.com](http://www.copleycontrols.com).



**EC DECLARATION OF CONFORMITY**

*Objects of this declaration:*

Product Description	Model Numbers
Xenus Plus Dual Axis EtherCAT Drive	XE2-230-20, XE2-230-20-R, 800-1818, 800-1819
Xenus Plus Dual Axis CANopen Drive	XP2-230-20, XP2-230-20-R
Xenus Plus Dual Axis MACRO Drive	XM2-230-20, XM2-230-20-R

*We, AnaLogic Corporation d/b/a Copley Controls, hereby declare that the objects of this declaration manufactured by us and described above are in conformity with EC Directives 2006/42/EC (Machinery Directive), 2004/108/EC (EMC Directive), 2006/95/EC (Low Voltage Directive) and 2011/65/EU (RoHS Directive). Conformity is declared under the following standards:*

**EMC**

IEC 61800-3:2004 /A1:2011     Adjustable Speed Electric Power Drive Systems – Part 3: EMC Requirements and Specific Test Methods. Category 3 PDS.

**PRODUCT SAFETY**

IEC 61800-5-1:2007     Adjustable Speed Electric Power Drive Systems – Part 5-1: Safety Requirements – Electrical, Thermal and Energy

**FUNCTIONAL SAFETY**

IEC 61800-5-2:2007     Adjustable Speed Electric Power Drive Systems – Part 5-2: Safety Requirements – Functional

ISO 13849-1:2006     Safety of Machinery – Safety-Related Parts of Control Systems – Part 1: General Principles for Design

*These products also comply with the following Underwriters Laboratories standard and SEMI standard*

UL 61800-5-1:2012     Adjustable Speed Electric Power Drive Systems – Part 5-1: Safety Requirements – Electrical, Thermal and Energy (File No. E168959)

SEMI F47-0706     Specification for Semiconductor Processing Equipment Voltage Sag Immunity

**Testing Performed By:**

Underwriters Laboratories 1285 Walt Whitman Road Melville, NY [www.ul.com](http://www.ul.com)  
 TÜV SÜD America Inc., 10040 Mesa Rim Road, San Diego, CA [www.TUVamerica.com](http://www.TUVamerica.com)  
 Test Site Services, Inc., P.O. Box 766, Marlboro, MA [www.testsiteservices.com](http://www.testsiteservices.com)

---

*Year in which the CE Marking was affixed:* 2014

---

*Signed for and on behalf of the above named manufacturer*

*Place and date of issue:*             Canton, MA USA             03/31/2015

*Name, function:*                     Timothy Walsh, Manager, Corporate Product Compliance & Reliability

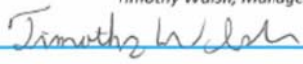
*Signature:* 

---

*EC Authorized Representative: BK Medical ApS, Mileparken 34, DK-2730, Herlev, Denmark, Tel: 45 44528100*

*Person Authorized to compile technical file: Jens Rasmussen, Director of Quality, BK Medical ApS*

---

AnaLogic Corporation d/b/a Copley Controls 20 Dan Road, Canton, MA 02021 781-828-8090 [www.copleycontrols.com](http://www.copleycontrols.com)

16-01368 rev00

**Original Instructions**

This manual is considered to be “original instructions” as defined in EC Directive 2006/42/EC and the contents have been verified by Copley Controls.

## Related Documentation

---

For important setup and operation information, see the *CME 2 User Guide* (Under Using CME2 here: <http://www.copleycontrols.com/Motion/Downloads/software.html>).

Users of the CANopen features should also read these Copley Controls documents:

- *CANopen Programmer's Manual*
  - *CMO (Copley Motion Objects) Programmer's Guide*
  - *CML Reference Manual*
- And, this guide for MACRO network users:
- *MACRO Network User Guide*

Also of related interest:

- *Indexer 2 Program User's Guide* (describes use of Indexer Program to create motion control sequences)
- *ASCII Programmer's Guide* (describes how to send ASCII format commands over a drive's serial bus to set up and control one or more drives)
- *Copley Amplifier Parameter Dictionary*
- *Copley Camming User Guide*
- *Copley Controls Serial Encoder Guide*
- *CPL User Guide*
- *Xenus Plus Dual-Axis STO Manual*

Links to these publications, along with other documents, data sheets and software releases, can be found at: <http://www.copleycontrols.com/Motion/Downloads/index.html>.

## Comments

---

Copley Controls welcomes your comments on this manual.

For contact information, see <http://www.copleycontrols.com/Motion/Contact/index.html>.

## Copyrights

---

No part of this document may be reproduced in any form or by any means, electronic or mechanical, including photocopying, without express written permission of Copley Controls.

Xenus XEL, XE2, XPL, XP2, XML and XM2 are registered trademarks of Copley Controls.

CME 2 is a registered trademark of Copley Controls.

Windows XP, Windows 7, Visual Basic, and .NET are trademarks or registered trademarks of the Microsoft Corporation.

LabVIEW is a registered trademark of National Instruments.

EtherCAT is a registered trademark and patented technology, licensed by Beckhoff Automation GmbH, Germany.

## Document Validity







---

We reserve the right to modify our products. The information in this document is subject to change without notice and does not represent a commitment by Copley Controls.

Copley Controls assumes no responsibility for any errors that may appear in this document.

**Product Warnings**

Observe all relevant state, regional and local safety regulations when installing and using this product. There are no user serviceable parts in the Xenus Plus servo drives. Removal of the cover or tampering with internal components will void the warranty

 <b>DANGER</b>	<b>DANGER: Hazardous voltages.</b>				
	<p>Exercise caution when installing and adjusting. Persons responsible for installing and commissioning Xenus Plus servo drives must be experienced in all aspects of electrical equipment installations.</p> <p><b>Failure to heed this warning can cause equipment damage, injury, or death.</b></p>				
 <b>DANGER</b>	<b>Risk of electric shock. Wait 5 minutes after disconnecting mains power before handling.</b>				
	<p>High-voltage circuits connected to mains power. After disconnecting mains power, wait 5 minutes before handling drive to allow for discharge of internal DC bus capacitance.</p> <table border="1" data-bbox="407 701 1151 785"> <tr> <td>XEL/XPL/XML</td> <td>J1, J2, J3</td> </tr> <tr> <td>XE2/XP2/XM2/800-1818/800-1819</td> <td>J1, J2, J3, and J4</td> </tr> </table>	XEL/XPL/XML	J1, J2, J3	XE2/XP2/XM2/800-1818/800-1819	J1, J2, J3, and J4
	XEL/XPL/XML	J1, J2, J3			
XE2/XP2/XM2/800-1818/800-1819	J1, J2, J3, and J4				
<p><b>Failure to heed this warning can cause equipment damage, injury, or death.</b></p>					
 <b>DANGER</b>	<b>Risk of unexpected motion with non-latched faults.</b>				
	<p>After the cause of a non-latched fault is corrected, the drive re-enables the PWM output stage without operator intervention. In this case, motion may re-start unexpectedly. Configure faults as latched unless a specific situation calls for non-latched behavior. When using non-latched faults, be sure to safeguard against unexpected motion.</p> <p><b>Failure to heed this warning can cause equipment damage, injury, or death.</b></p>				
 <b>DANGER</b>	<b>Using CME 2 or serial commands may affect or suspend CANopen operations.</b>				
	<p>When operating the drive as a CANopen node, the use of CME 2 or ASCII serial commands may affect CANopen operations in progress. Using such commands to initiate motion may cause CANopen operations to suspend. CANopen operations may restart unexpectedly when the commanded motion is stopped.</p> <p><b>Failure to heed this warning can cause equipment damage, injury, or death.</b></p>				
 <b>DANGER</b>	<b>Latching an output does not eliminate the risk of unexpected motion with non-latched faults.</b>				
	<p>Associating a fault with a latched, custom-configured output does not latch the fault itself. After the cause of a non-latched fault is corrected, the drive re-enables without operator intervention. In this case, motion may re-start unexpectedly. For more information, see <a href="#">Clearing Latched Faults (p.51)</a>.</p> <p><b>Failure to heed this warning can cause equipment damage, injury, or death.</b></p>				
 <b>DANGER</b>	<b>Use equipment as described.</b>				
	<p>Operate drives within the specifications provided in this manual.</p> <p><b>Failure to heed this warning can cause equipment damage, injury, or death.</b></p>				
 <b>DANGER</b>	<b>Drive heatsink surfaces can exceed 80C and regen resistor surface can exceed 100C depending on drive use conditions</b>				
	<p>Do not touch drive heatsink during operation and allow it to cool before handling after power is removed.</p> <p><b>Failure to heed this warning can cause injury</b></p>				



This page for notes.

# CHAPTER

# 1: INTRODUCTION

This chapter provides an overview of the Copley Controls Xenus Plus drives.

Contents include:

1.1: Xenus Plus Family Overview .....	11
1.2: CME 2 .....	12
1.3: CML/CMO .....	13
1.4: Copley Virtual Machine (CVM) .....	13
1.5: Indexer 2 .....	13
1.6: CPL .....	13

## 1.1: Xenus Plus Family Overview

Each Xenus Plus servo drive provides 100% digital control of brushless or brush motors in an off-line powered package. It can also control a Copley Controls ServoTube motor. Xenus Plus can operate from single or three-phase mains with a continuous power output of up to 4 kW.

Xenus Plus comes in six basic models to support three network interface protocols: single axis XEL and dual axis XE2, which support CANopen over EtherCAT, the single axis XML and dual axis XM2, which support MACRO, and single axis XPL and dual axis XP2, which support CANopen.

All of the Xenus Plus models provide a Safe Torque off (STO) function. Two inputs are provided which, when de-energized, prevent the upper and lower devices in the PWM outputs from being operated by the digital control core. This provides a positive OFF capability that cannot be overridden by the control firmware, or associated hardware components. When the inputs are energized, the control core will be able to control the on/off state of the PWM outputs. Although all models have the STO feature, there are important differences in the STO design between the Single Axis (XEL/XPL/XML) and the Dual Axis (XE2/XP2/XM2/800/1818/800-1819) versions.

The STO circuit in the single axis models was designed using guidance from IEC 61800-5-2, an international standard that specifies requirements for motor drive functional safety features including STO.

The STO feature in the dual axis models was developed in accordance with several functional safety standards and has both SIL and Category/Performance Level ratings. The design and development of the STO feature on these models are being submitted to TÜV SÜD for approval. Following approval the Xenus Plus Dual Axis products will bear the TÜV SÜD Functional Safety mark. For more information on STO for the Xenus Plus Dual Axis models, see the *Xenus Plus Dual-Axis STO Manual*.

Xenus Plus models support a wide range of feedback devices. The standard versions support digital quadrature encoders, analog sin/cos encoders, and EnDat, BiSS, SSI, and Absolute A encoders. The -R version supports brushless resolvers. The standard and -R versions can emulate a digital quadrature encoder output from the analog encoder or resolver respectively.

Xenus Plus models can operate in several basic ways:

- As a traditional motor drive accepting current, velocity or position commands from an external controller. In current and velocity modes they can accept  $\pm 10$  Vdc analog, digital 50% PWM or PWM/polarity inputs. In position mode, inputs can be incremental position commands from step-motor controllers in Pulse and Direction or Count Up/Count Down format, as well as A/B quadrature commands from a master-encoder. Pulse-to-position ratio is programmable for electronic gearing.
- As a node on a CANopen network. CANopen compliance allows the drive to take instruction from a master application to perform torque, velocity, and position profiling, interpolated position, and homing operations. Multiple drives can be tightly synchronized for high performance coordinated motion.
- As a node on an EtherCAT or MACRO network.
- As a stand-alone controller running CVM control programs such as the Indexer 2 Program. It can also be controlled directly over an RS232 serial link with simple ASCII format commands.

Mains input voltage to the drive can range from 100 to 240 Vac, single or three-phase, and 47 to 63 Hz. This allows Xenus Plus the ability to work in the widest possible range of industrial settings. Several models are available, with peak output current ratings of 18 to 40 Amps:

Model		Data		
Standard	Resolver	Continuous Current Adc (Arms)	Peak Current Adc (Arms)	Vac
XEL-230-18 XML-230-18 XPL-230-18	XEL-230-18 -R XML-230-18 -R XPL-230-18 -R	6 (4.24)	18 (12.7)	100~240 1Ø, 3Ø 50~60 Hz
XEL-230- 36 XML-230- 36 XPL-230- 36	XEL-230- 36 -R XML-230- 36 -R XPL-230- 36 -R	12 (8.49)	36 (25.5)	
XEL-230-40 XML-230-40 XPL-230-40	XEL-230-40 -R XML-230-40 -R XPL-230-40 -R	20 (14.1)	40 (28.3)	
XE2-230-20 XP2-230-20 XM2-230-20 800-1819	XE2-230-20-R XP2-230-20-R XM2-230-20-R	10 (7.07)	20 (14.1)	
800-1818	-	4.5 (3.18)	9 (6.36)	
- The XEL/XML/XPL model numbers may be followed by “-HL” or “-HS” to specify the low profile or standard heatsink option respectively				

Note that as a convenience to customers Copley offers a certain level of customization to tailor Xenus Plus drives for a given application. This level of customization is most often limited to factory configuration of user programmable parameters, but can include signal level hardware differences to accommodate less common motor feedback devices. Drives with this customization carry the “Xenus Plus” or “Xenus Plus 2-Axis” marking, but are assigned customer specific model numbers that begin with “800-“ followed by four or five alphanumeric characters. These Xenus Plus and Xenus Plus 2-Axis “800” number models are included within the scope of this manual unless otherwise noted.

A separate +24 Vdc logic supply is required to power the internal logic and control circuits. These are isolated from the high-voltage power supply and inverter stage that connect to the mains. This simplifies system design by allowing the mains to be completely disconnected from the drive for safety reasons while allowing the logic side of the drive to stay powered. This allows the drive to retain position information and maintain communication through the digital I/O or over the serial or CAN, EtherCAT, or MACRO ports when disconnected from the mains.

The Xenus Plus models are RoHS compliant.

## 1.2: CME 2

Drive commissioning is fast and simple using Copley Controls CME 2 software. CME 2 communicates with Xenus Plus via an RS-232, CANopen, or EtherCAT link, and all of the operations needed to configure the drive are accessible through CME 2.

The multi-drop feature allows CME 2 to use a single RS-232 serial connection to one drive as a gateway to other drives linked together by CAN bus connections.

Auto phasing of brushless motor Hall sensors and phase wires eliminates “wire and try.” Connections are made once and CME 2 does the rest. Encoder or resolver wire swapping to establish the direction of positive motion is also eliminated.

Motor data can be saved as .CCM files. Drive data is saved as .CCX files that contain all drive settings plus motor data. This makes it possible to quickly set up drives by copying configurations from one drive to another.

## 1.3: CML/CMO

Copley Motion Libraries (CML) and Copley Motion Objects (CMO) make CANopen or EtherCAT network commissioning fast and simple. All network housekeeping is taken care of automatically by a few simple commands linked into your application program. CML provides a suite of C++ libraries, allowing a C++ application program to communicate with and control a drive over the CANopen network. CMO provides a similar suite of COM objects that can be used by Visual Basic, .NET, LabVIEW, or any other program supporting the Microsoft COM object interface.

## 1.4: Copley Virtual Machine (CVM)

Copley Virtual Machine (CVM) is an embedded virtual programmable controller used to download Copley's Indexer 2 or CPL programs to Copley drives. It is accessed via CME 2 and can be opened from CME 2's main window.

## 1.5: Indexer 2

Copley's Indexer 2 is an indexer configured and programmed using the tools built into CME 2.

## 1.6: CPL

CPL is Copley's high level programming language for writing custom CVM programs. It expands on the features of Indexer 2 with interrupts and features that are faster and more flexible, including looping and branching capabilities.

# CHAPTER

## 2: OPERATIONAL THEORY

This chapter describes the basics of Xenus Plus operation. Contents include:

- 2.1: Drive Power Architecture ..... 15
- 2.2: Operating Modes ..... 17
- 2.3: Input Command Types ..... 28
- 2.4: Communication ..... 33
- 2.5: Status Indicators ..... 38
- 2.6: Protection ..... 50
- 2.7: Position and Velocity Errors ..... 52
- 2.8: Inputs XEL/XPL/XML ..... 55
- 2.9: Inputs XE2/XP2/XM2/800-1819 ..... 56
- 2.10: Outputs, XEL/XPL/XML ..... 58
- 2.11: Outputs, XE2/XP2/XM2/800-1819 ..... 58
- 2.12: Brake Operation ..... 58
- 2.13: Regen Resistor Theory ..... 61

## 2.1: Drive Power Architecture

Power distribution within Xenus Plus is divided into three sections: +24 Vdc, logic/signal, and high voltage. Each is isolated from the other.

### 2.1.1: Logic/Signal Power

---

An internal DC/DC converter operates from the +24 Vdc Logic Supply input and creates the required logic/signal operating voltages, the isolated voltages required for the high-voltage control circuits, and a +5 Vdc supply for powering the motor encoder and Hall circuits.

With the Xenus Plus Single Axis drives, digital inputs IN1~6 and IN15, analog inputs AIN1~3, digital outputs OUT1~3, Hall inputs and encoder inputs are all referenced to signal ground. Inputs IN7~10 and IN11~14 are groups of four opto-isolated inputs with a common terminal for each group. Outputs OUT4~5 are two-terminal Darlington opto-isolators. The brake output OUT6 is opto-isolated and referenced to the +24Vdc return. The CAN interface is optically isolated.

With the Xenus Plus Dual Axis drives, digital inputs IN1~5, IN10~11, and IN16~22, analog inputs AIN1~2, Hall inputs, and encoder inputs are referenced to signal ground. Inputs IN6~9 and IN16~19 are two groups of four opto-isolated inputs with a common terminal for each group. Brake outputs OUT6~7 are opto-isolated and referenced to the 24V return. Outputs OUT1~5 are two-terminal MOSFET SSRs. The CAN interface is optically isolated.

Deriving internal operating voltages from a separate source enables the drive to stay on-line when the mains have been disconnected for emergency-stop or operator-intervention conditions. This allows CAN bus and serial communications to remain active so that the drive can be monitored by the control system while the mains power is removed.

### 2.1.2: High Voltage

---

Mains power drives the high-voltage section. It is rectified and capacitor-filtered to produce the DC bus: the DC “link” power that drives the PWM inverter, where it is converted into the voltages that drive a three-phase brushless or DC brush motor. An internal solid-state switch, together with an external power resistor, provides dissipation during regeneration when the mechanical energy of the motor is converted back into electrical energy. This prevents charging the internal capacitors to an overvoltage condition.

**2.1.3: Power and Isolation Diagram**

The graphic below shows the different power sections within the Xenus Plus drives and the isolation barriers between them. Note that the diagram shows the power and feedback connections to one motor and applies directly to the single axis model. Although not shown, connections to a second motor (applicable for the dual axis drive models) are essentially duplicates of the first. The second motor power connections originate from a second PWM inverter in the Mains circuit block and the second motor feedback connections originate from a second set of Feedback Power and Decoding circuitry in the Signal GND referenced block.

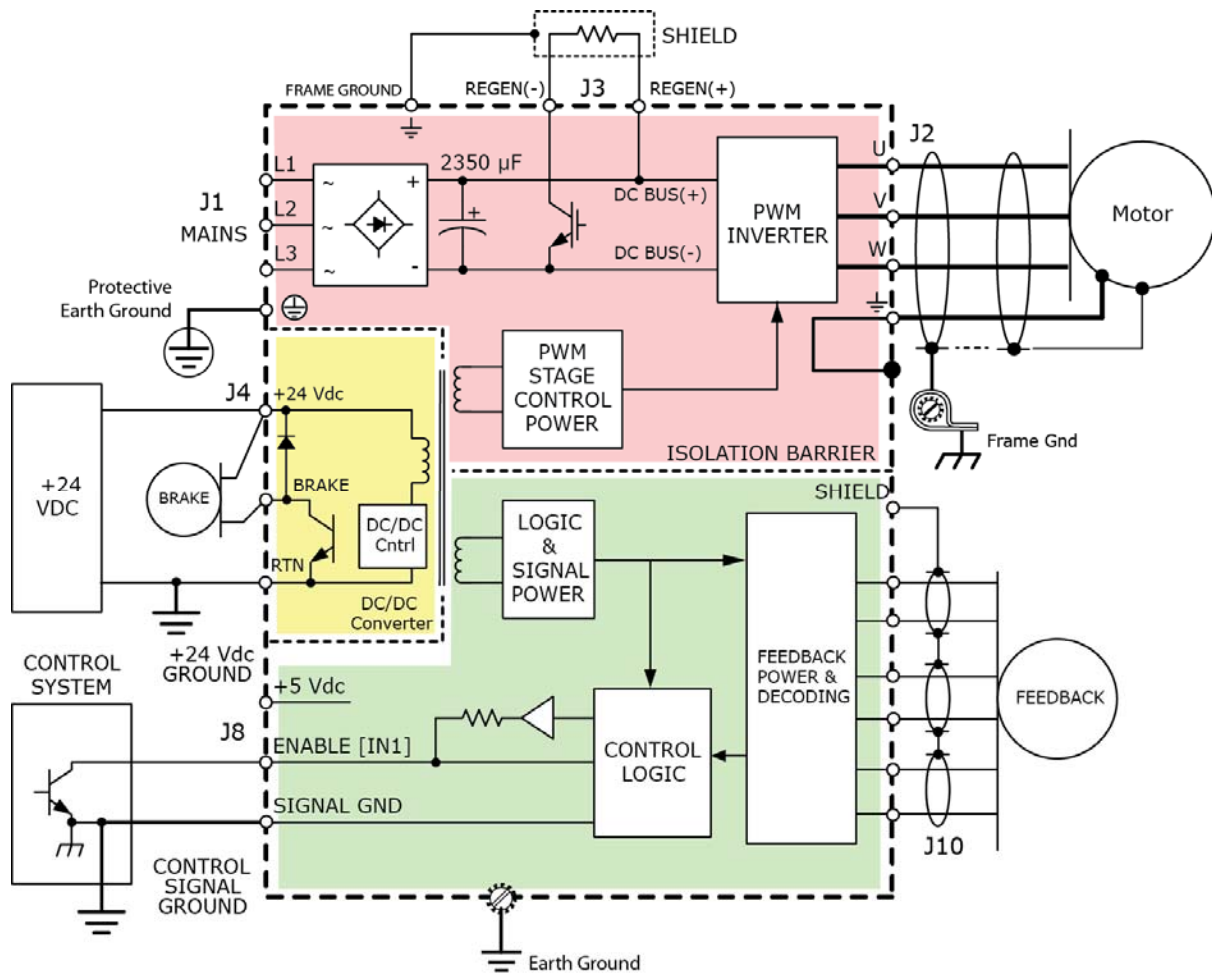

The isolation barriers associated with the general purpose inputs and outputs or the STO inputs are not shown.



## 2.2: Operating Modes

### 2.2.1: Commutation Modes

---

The drive supports three commutation modes to drive brush and brushless motors: brushless sinusoidal, brushless trapezoidal, and DC brush.

Brushless motors driven with sinusoidal phase currents are commonly called AC brushless, while those which commute using only Hall feedback are called DC brushless motors. In DC brushless motors, only two phases are driven at a time and the current between them is controlled to be DC. AC brushless motors drive all three phases, each with sinusoidal currents and 120 degrees of phase shift between them. In most applications, sinusoidal commutation is preferred over trapezoidal, because it reduces torque ripple and offers the smoothest motion at any velocity or torque. In the sinusoidal commutation mode, an encoder or a resolver are required for all modes of operation.

When driving a DC brush motor, the drive operates as a traditional H-Bridge drive using only the U & V PWM outputs.

### 2.2.2: Position Feedback Types

---

#### Encoder and Resolver Support

The standard versions of the Xenus Plus drives support digital quadrature encoders, analog sin/cos encoders, and a variety of serial and absolute encoder formats.

Resolver versions, designated by “-R” in the model number, support standard, single speed, transmit-type resolvers.

Digital quadrature and sin/cos analog encoders are “incremental” types that typically use Hall feedback for commutating brushless motors. Resolvers and absolute rotary encoders do not require Halls for commutation because they provide the absolute feedback of the position of the motor rotor.

#### Multi-Mode Port

All versions support a multi-mode port. This interface can be configured to:

- Provide a buffered digital encoder output based on the digital quadrature encoder input.
- Provide an emulated digital encoder output based on the analog encoder or resolver input.
- Provide an emulated serial encoder output.
- Provide a second digital encoder input to be used in the dual encoder position mode. In this mode, an encoder attached to the load provides position loop feedback, and the motor encoder or resolver provides velocity loop feedback.

### 2.2.3: Control Modes and Loops

---

#### Nesting of Control Loops and Modes

Copley Controls drives use up to three nested control loops - current, velocity, and position - to control a motor in three associated operating modes.

#### Control Loops Illustration

In position mode, the drive uses all three loops. As shown below, the position loop drives the nested velocity loop, which drives the nested current loop. In velocity mode, the velocity loop drives the current loop. In current mode, the current loop is driven directly by external or internal current commands.

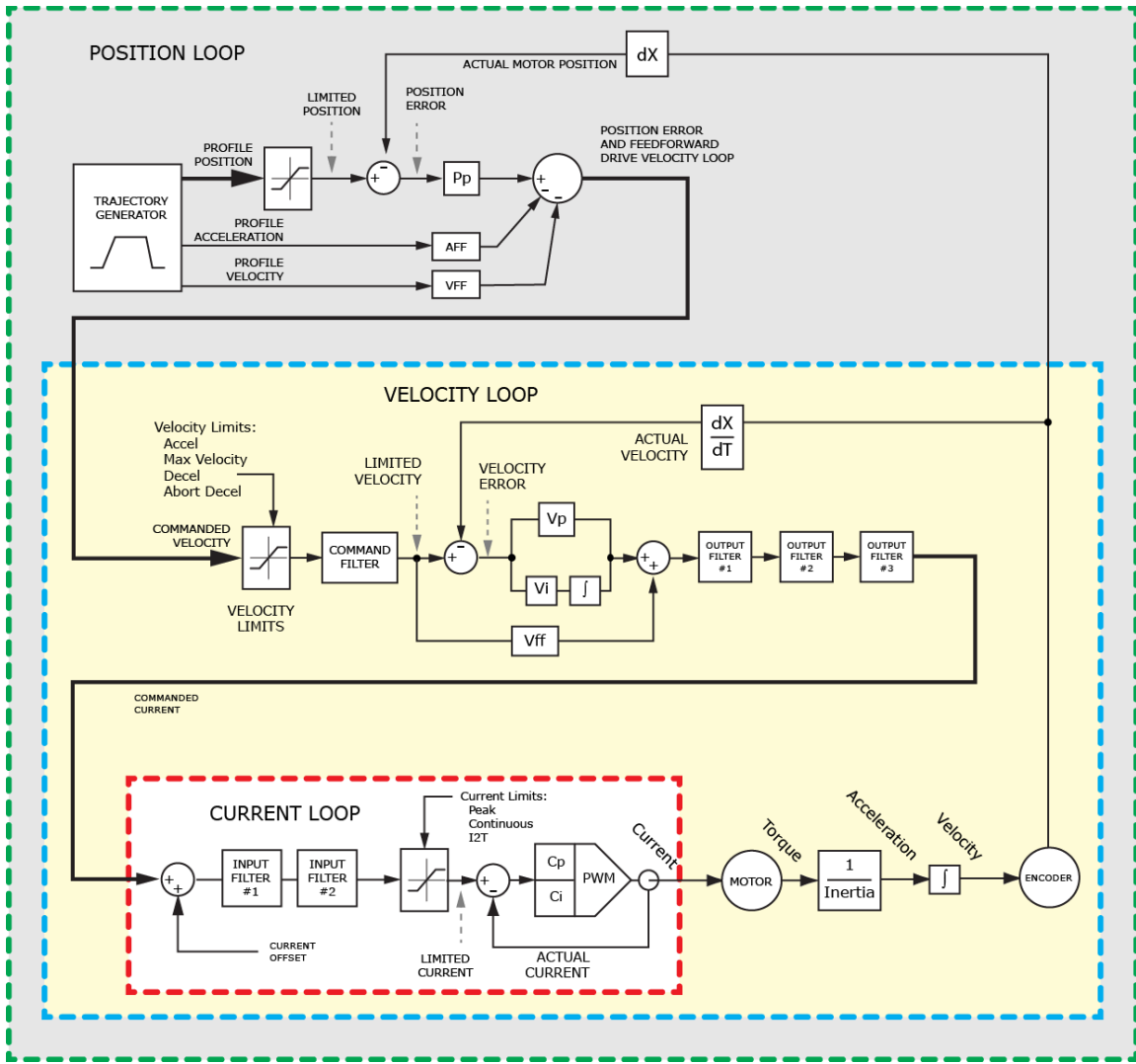

**Basic Attributes of All Control Loops**

These loops (and servo control loops in general) share several common attributes:

Loop Attribute	Description
Command input	Every loop is given a value to which it will attempt to control. For example, the velocity loop receives a velocity command that is the desired motor speed.
Limits	Limits are set on each loop to protect the motor and/or mechanical system.
Feedback	The nature of servo control loops is that they receive feedback from the device they are controlling. For example, the position loop uses the actual motor position as feedback.
Gains	These are constant values that are used in the mathematical equation of the servo loop. The values of these gains can be adjusted during drive setup to improve the loop performance. Adjusting these values is often referred to as tuning the loop.
Output	The loop generates a control signal. This signal can be used as the command signal to another control loop or the input to a power drive.

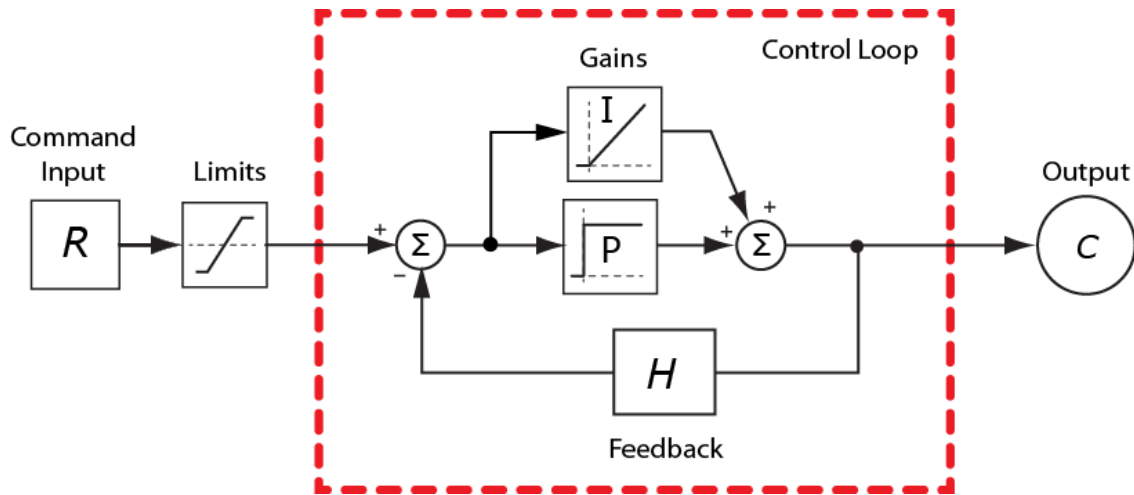

### 2.2.4: Current Mode and Current Loop

#### Current Loop Diagram

As shown below, the “front end” of the current loop is a limiting stage. The limiting stage accepts a current command, applies limits, and passes a limited current command to the summing junction. The summing junction takes the limited current command, subtracts the actual current (represented by the feedback signal), and produces an error signal. This error signal is then processed using the integral and proportional gains to produce a command. This command is then applied to the drive’s power stage.

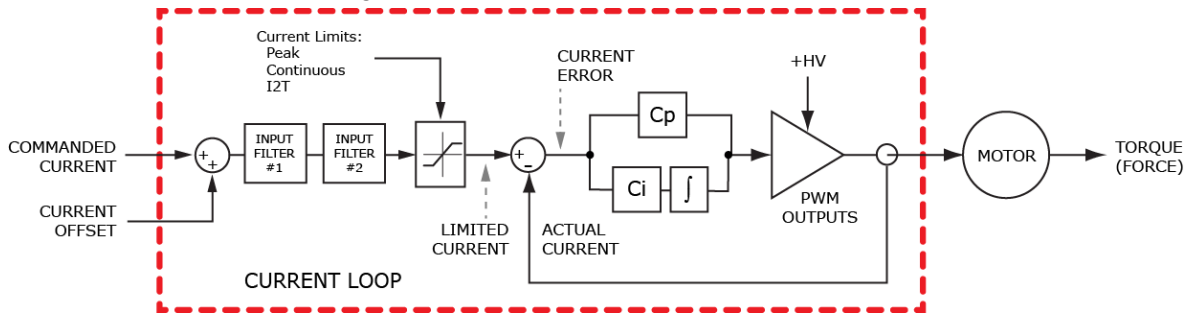

#### Current Loop Inputs

- The drive’s analog or PWM inputs.
- A network command, CAN, or RS-232 Serial.
- A CVM control program.
- The drive’s internal function generator.

In velocity or position modes, the current command is generated by the velocity loop.

#### Offset

The current loop offset is intended for use in applications where there is a constant force applied to, or required of, the servomotor and the system must control this force. Typical applications would be a vertical axis holding against gravity, or web tensioning. This offset value is summed with the current command before the limiting stage.

#### Limits

The current command is limited based on the following parameters:

Limiters	Description
Peak Current Limit	Maximum current that can be generated by the drive for a short duration of time. This value cannot exceed the peak current rating of the drive.
Continuous Current Limit	Maximum current that can be constantly generated by the drive.
I <sup>2</sup> T Time Limit	Maximum amount of time that the peak current can be applied to the motor before it must be reduced to the continuous limit or generate a fault. For more details, see <a href="#">I<sup>2</sup>T Time Limit Algorithm</a> (p. 137). Note: Although the current limits set by the user may exceed the drive's internal limits, the drive operates using both sets of limits in parallel, and therefore will not exceed its own internal limits regardless of the values programmed.
Ramp	Rate of change in current command.

**Current Loop Gains**

The current loop uses these gains:

<b>Gain</b>	<b>Description</b>
Cp - Current loop proportional	The current error (the difference between the actual and the limited commanded current) is multiplied by this value. The primary effect of this gain is to increase bandwidth (or decrease the step-response time) as the gain is increased.
Ci - Current loop integral	The integral of the current error is multiplied by this value. Integral gain reduces the current error to zero over time. It controls the DC accuracy of the loop, or the flatness of the top of a square wave signal. The error integral is the accumulated sum of the current error value over time.

**Current Loop Output**

The output of the current loop is a command that sets the duty cycle of the PWM output stage of the drive.

**Auto Tune**

CME 2 provides a current loop Auto Tune feature, which automatically determines optimal Cp and Ci values for the motor. For more information, see the *CME 2 User Guide*.

### 2.2.5: Velocity Mode and Velocity Loop

#### Velocity Loop Diagram

As shown below, the velocity loop limiting stage accepts a velocity command, applies limits, and passes a limited velocity command to the input filter. The filter then passes a velocity command to the summing junction. The summing junction subtracts the actual velocity, represented by the feedback signal, and produces an error signal. (The velocity loop feedback signal is always from the motor feedback device even when an additional encoder is attached to the load.) The error signal is then processed using the integral and proportional gains to produce a current command. Programmable digital filters are provided on both the input and output command signals.

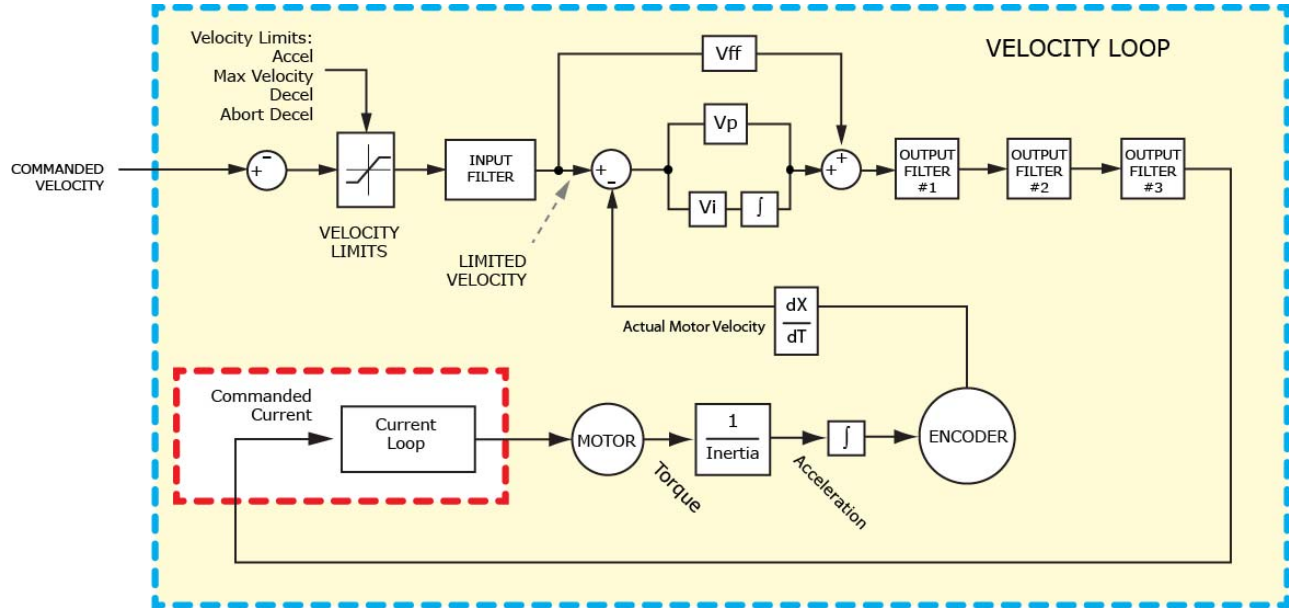

#### Inputs

In velocity mode, the velocity command comes from one of the following:

- The drive’s analog or PWM inputs.
- A network command, CAN, or RS-232 Serial.
- A CVM control program.
- The drive’s internal function generator.

In position mode, the velocity command is generated by the position loop.

**Velocity Loop Limits**

The velocity command is limited based on the following set of parameters designed to protect the motor and/or the mechanical system.

Limiters	Description
Velocity Limit	Sets the maximum velocity command input to the velocity loop.
Acceleration Limit	Limits the maximum acceleration rate of the commanded velocity input to the velocity loop. This limit is used in velocity mode only.
Deceleration Limit	Limits the maximum deceleration rate of the commanded velocity input to the velocity loop. This limit is used in velocity mode only.
Fast Stop Ramp	Specifies the deceleration rate used by the velocity loop when the drive is hardware disabled. (Fast stop ramp is not used when drive is software disabled.) If the brake delay option is programmed, the fast stop ramp is used to decelerate the motor before applying the brake.  Note that Fast Stop Ramp is used only in velocity mode. In position mode, the trajectory generator handles controlled stopping of the motor. There is one exception: if a non-latched following error occurs in position mode, then the drive drops into velocity mode and the Fast Stop Ramp is used.  For more information, see <a href="#">Following Error Fault Details (p. 53)</a> .

**Diagram: Effects of Limits on Velocity Command**

The following diagram illustrates the effects of the velocity loop limits.

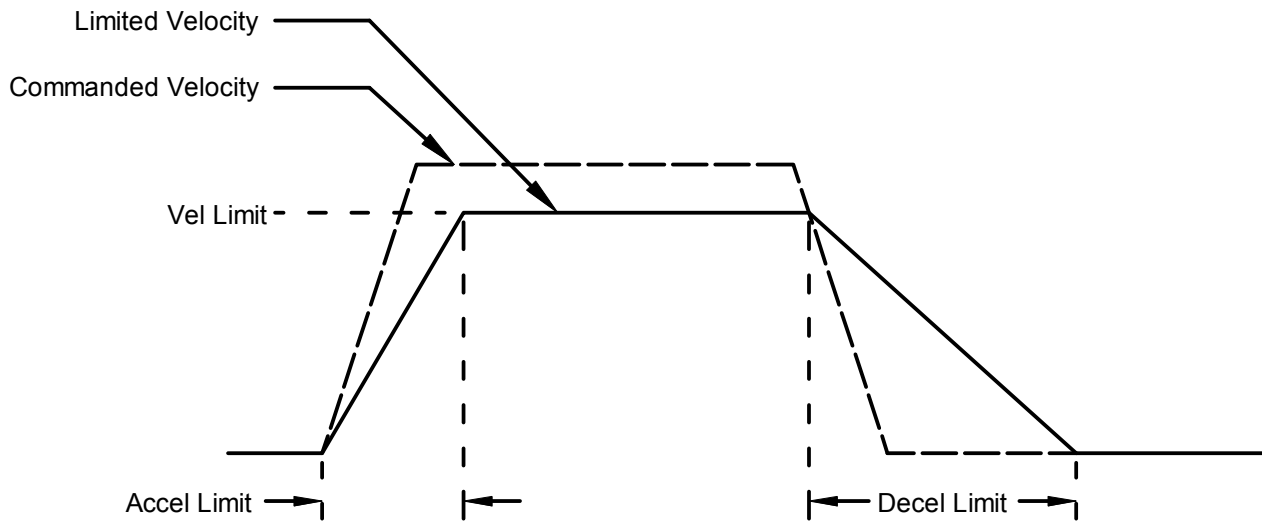

**Velocity Loop Gains**

The velocity loop uses these gains:

Gain	Description
Vp - Velocity loop proportional	The velocity error (the difference between the actual and the limited commanded velocity) is multiplied by this gain. The primary effect of this gain is to increase bandwidth (or decrease the step-response time) as the gain is increased.
Vi - Velocity loop integral	The integral of the velocity error is multiplied by this value. Integral gain reduces the velocity error to zero over time. It controls the DC accuracy of the loop, or the flatness of the top of a square wave signal. The error integral is the accumulated sum of the velocity error value over time.

**Velocity Gains Shift**

The Velocity Gains Shift feature adjusts the resolution of the units used to express Vp and Vi, providing more precise tuning. If the non-scaled value of Vp or Vi is 64 or less, the Low Gains Shift option is available to increase the gains adjustment resolution. (Such low values are likely to be called for when tuning a linear motor with an encoder resolution finer than a micrometer.) If the non-scaled value of Vp or Vi is 24001 or higher, the High Gains Shift option is available to decrease the gains adjustment resolution.

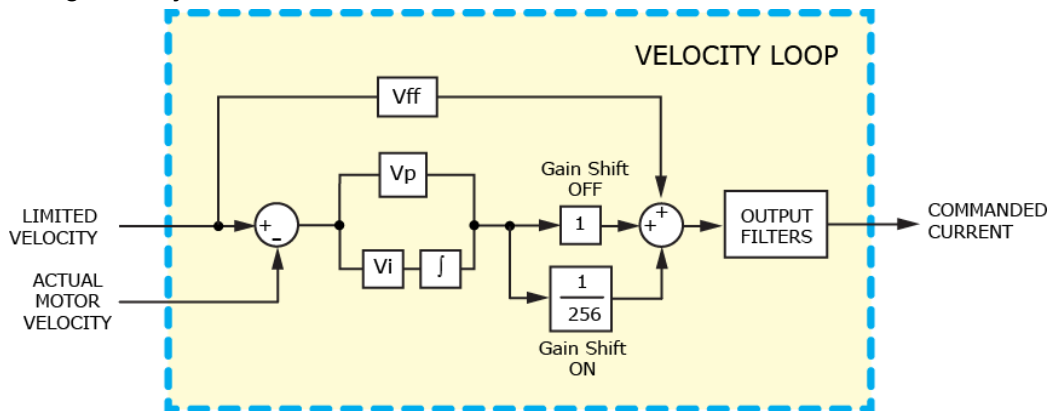

**Velocity Loop Command and Output Filters**

The velocity loop contains two programmable digital filters. The input filter should be used to reduce the effects of a noisy velocity command signal. The output filter can be used to reduce the excitation of any resonance in the motion system.

Two filter classes can be programmed: the Low-Pass and the Custom Bi-Quadratic. The Low-Pass filter class includes the Single-Pole and the Two-Pole Butterworth filter types. The Custom Bi-Quadratic filter allows advanced users to define their own filters incorporating two poles and two zeros. For more information on the velocity loop filters, see the *CME 2 User Guide*.

**Velocity Loop Outputs**

The output of the velocity loop is a current command used as the input to the current loop.



**2.2.6: Position Mode and Position Loop**

**Position Loop Diagram**

The drive receives position commands from the digital or analog command inputs, over the CAN interface or serial bus, or from the CVM Control Program. When using digital or analog inputs, the drive's internal trajectory generator calculates a trapezoidal motion profile based on trajectory limit parameters. When using the CAN bus, serial bus, or CVM Control Program, a trapezoidal or S-curve profile can be programmed. The trajectory generator updates the calculated profile in real time as position commands are received.

The output of the generator is an instantaneous position command (limited position). In addition, values for the instantaneous profile velocity and acceleration are generated. These signals, along with the actual position feedback, are processed by the position loop to generate a velocity command.

To bypass the trajectory generator while in digital or analog position modes, set the maximum acceleration to zero. The only limits in effect will now be the velocity loop velocity limit and the current limits. (Note that leaving the maximum acceleration set to zero will prevent other position modes from operating correctly.)

The following diagram summarizes the position loop.

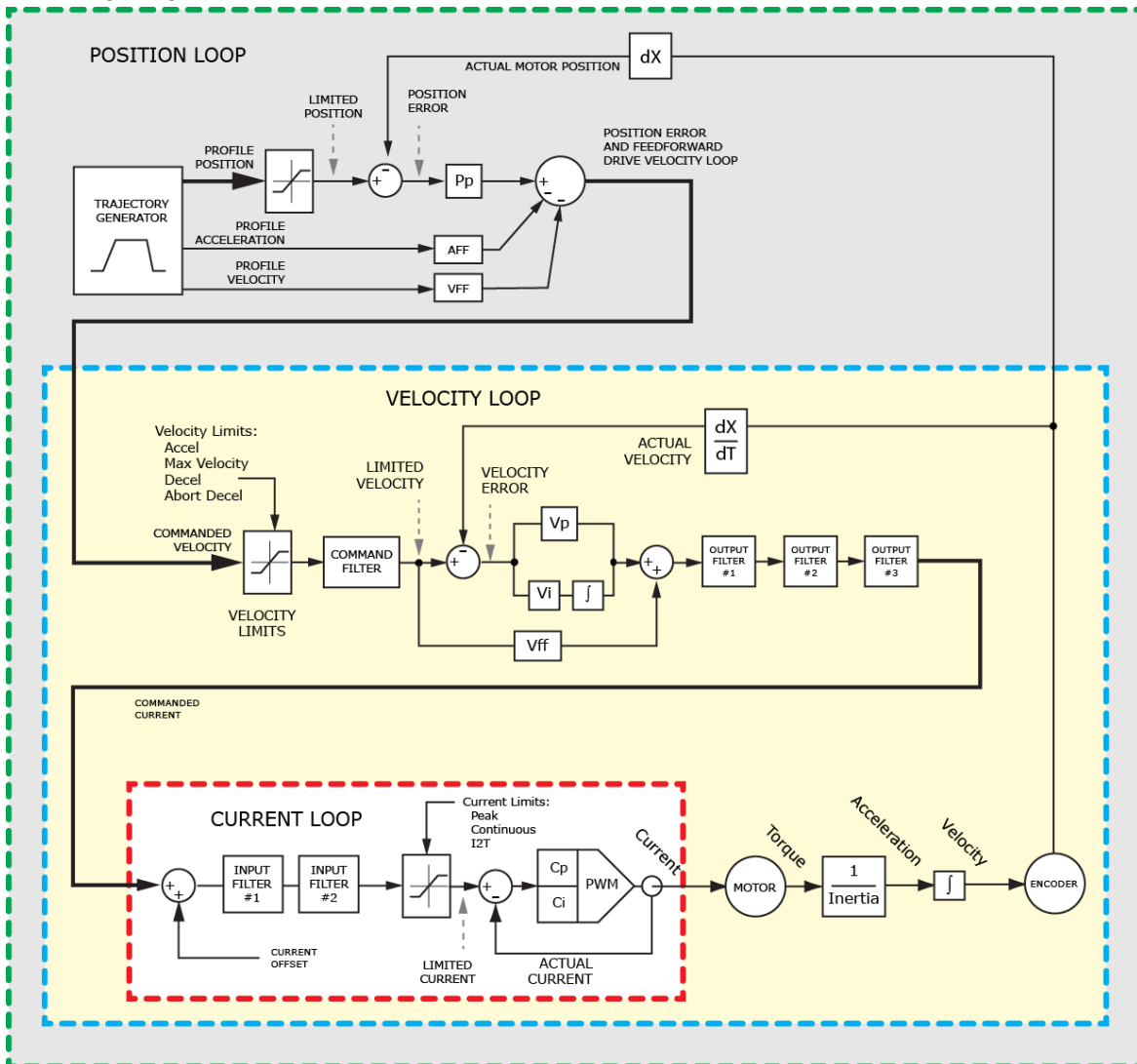

### Trajectory Limits

In position mode, the trajectory generator applies the following user-set limits to generate the motion profile.

Limitier	Description
Maximum Velocity	Limits the maximum speed of the profile.
Maximum Acceleration	Limits the maximum acceleration rate of the profile.
Maximum Deceleration	Limits the maximum deceleration rate of the profile.
Abort Deceleration	Specifies the deceleration rate used by the trajectory generator when motion is aborted.

### Position Loop Inputs From the Trajectory Generator

The position loop receives the following inputs from the trajectory generator.

Input	Description
Profile Velocity	The instantaneous velocity value of the profile. Used to calculate the velocity feed forward value.
Profile Acceleration	The instantaneous acceleration/deceleration value of the profile. Used to calculate the acceleration feed forward value.
Limited Position	The instantaneous commanded position of the profile. Used with the actual position feedback to generate a position error.

### Position Loop Gains

The following gains are used by the position loop to calculate the velocity command:

Gain	Description
Pp - Position loop proportional	The loop calculates the position error as the difference between the actual and limited position values. This error in turn is multiplied by the proportional gain value. The primary effect of this gain is to reduce the following error.
Vff - Velocity feed forward	The value of the profile velocity is multiplied by this value. The primary effect of this gain is to decrease following error during constant velocity.
Aff - Acceleration feed forward	The value of the profile acceleration is multiplied by this value. The primary effect of this gain is to decrease following error during acceleration and deceleration.
Gain Multiplier	The output of the position loop is multiplied by this value before being passed to the velocity loop.

### Position Loop Feedback

Xenus Plus supports two position feedback configurations

- Single sensor. Position loop feedback comes from the encoder or resolver on the motor.
- Dual sensor. Position loop feedback comes from the encoder attached to the load.

(Note that in either case, velocity loop feedback comes from the motor encoder or resolver.) For more information, see [Position Feedback \(p. 17\)](#).

### Position Loop Output

The output of the position loop is a velocity command used as the input to the velocity loop.

**Position Wrap**

The position wrap feature causes the position reported by the drive to “wrap” back to zero at a user-defined value instead of continually increasing. Once set, the reported position will be between 0 and n-1 where n is the user entered wrap value. This feature is most useful for rotary loads that continually turn in one direction and only the position within a revolution is of interest to the user.

With the wrap value set, relative moves will move the relative distance called for. Example: if the wrap value is set to 1000 and a relative move of 2500 is commanded, the axis will turn  $2 \frac{1}{2}$  revolutions.

Absolute moves will move the shortest distance to arrive at the programmed position. This could be in the positive or negative direction. Moves programmed to a point greater than the wrap value will cause an error.

To configure the position wrap feature, see the *CME 2 User Guide*.

## 2.3: Input Command Types

The drive can be controlled by a variety of external sources: analog voltage or digital inputs, CAN network (CANopen), EtherCAT, CoE (CANopen over EtherCAT), MACRO, or over an RS-232 serial connection using ASCII commands. The drive can also function as a stand-alone motion controller running an internal CVM program or using its internal function generator.

### 2.3.1: Analog Command Input

#### Overview

The drive can be driven by an analog voltage signal through the analog command input. The drive converts the signal to a current, velocity, or position command as appropriate for current, velocity, or position mode operation, respectively.

The analog input signal is conditioned by the scaling, dead band, and offset settings.

#### Scaling

The magnitude of the command generated by an input signal is proportional to the input signal voltage. Scaling controls the input-to-command ratio, allowing the use of an optimal command range for any given input voltage signal range.

For example, in current mode, with default scaling, +10 Vdc of input generates a command equal to the drive's peak current output; +5 Vdc equals half of that.

Scaling could also be useful if, for example, the signal source generates a signal range between 0 and +10 Vdc, but the command range only requires +7.5 Vdc of input. In this case, scaling allows the drive to equate +7.5 Vdc with the drive's peak current (in current mode) or maximum velocity (in velocity mode), increasing the resolution of control.

#### Dead Band

To protect against unintended response to low-level line noise or interference, the drive can be programmed with a "dead band" to condition the response to the input signal voltage. The drive treats anything within the dead band ranges as zero, and subtracts the dead band value from all other values. For instance, with a dead band of 100 mV, the drive ignores signals between -100 mV and +100 mV, and treats 101 mV as 1 mV, 200 mV as 100 mV, and so on.

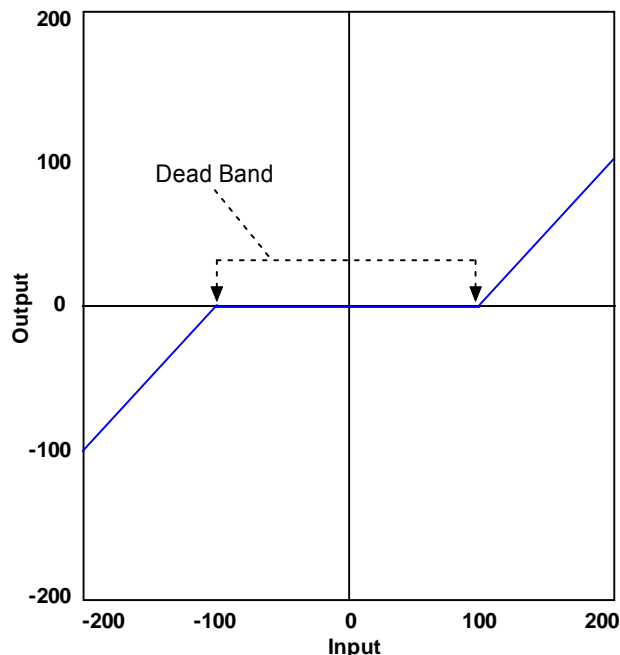

**Offset**

To remove the effects of voltage offsets between the controller and the drive in open loop systems, CME 2 provides an Offset parameter and a Measure function. The Measure function takes 10 readings of the analog input voltage over a period of approximately 200 ms, averages the readings, and then displays the results. The Offset parameter allows the user to enter a corrective offset to be applied to the input voltage.

The offset can also set up the drive for bi-directional operation from a uni-polar input voltage. An example of this would be a 0 to +10 Vdc velocity command that had to control 1000 rpm CCW to 1000 rpm CW. Scale would be set to 2000 rpm for a +10 Vdc input and Offset set to -5V. After this, a 0 Vdc input command would be interpreted as -5 Vdc, which would produce 1000 rpm CCW rotation. A +10 Vdc command would be interpreted as +5 Vdc and produce 1000 rpm CW rotation.

**Monitoring the Analog Command Voltage**

The analog input voltage can be monitored in the CME 2 control panel and oscilloscope. The voltage displayed in both cases is after both offset and deadband have been applied.

**Analog Command in Position Mode**

The Xenus Plus Analog Position command operates as a relative motion command. When the drive is enabled the voltage on the analog input is read. Then any change in the command voltage will move the axis a relative distance, equal to the change in voltage, from its position when enabled.

To use the analog position command as an absolute position command, the drive should be homed every time it is enabled. The Homing sequence may be initiated by CAN, ASCII serial, or CVM Indexer program commands.

### 2.3.2: PWM Input

#### Two Formats

The drive can accept a pulse width modulated signal (PWM) signal to provide a current command in current mode and a velocity command in velocity mode. The PWM input can be programmed for two formats: 50% duty cycle (one-wire) and 100% duty cycle (two-wire).

#### 50% Duty Cycle Format (One-Wire)

The input takes a PWM waveform of fixed frequency and variable duty cycle. As shown below, a 50% duty cycle produces zero output from the drive. Increasing the duty cycle toward 100% commands a positive output, and decreasing the duty cycle toward zero commands a negative output.

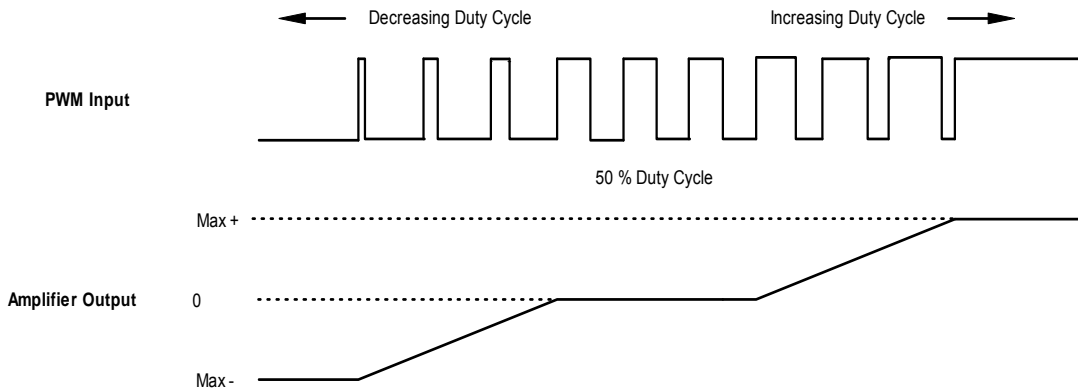

The command can be inverted so that increased duty cycle commands negative output and vice versa.

#### 100% Duty Cycle Format (Two-Wire)

One input takes a PWM waveform of fixed frequency and variable duty cycle, and the other input takes a DC level that controls the polarity of the output. A 0% duty cycle creates a zero command, and a 100% duty cycle creates a maximum command level. The command can be inverted so that increasing the duty cycle decreases the output and vice versa.

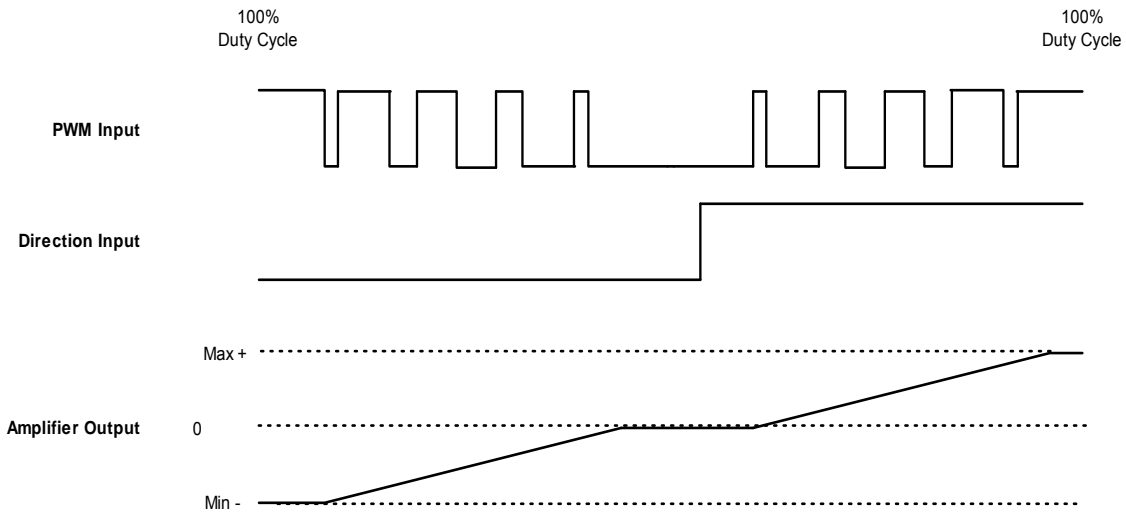

#### Failsafe Protection from 0 or 100% Duty Cycle Commands

In both formats, the drive can be programmed to interpret 0 or 100% duty cycle as a zero command. This provides a measure of safety in case of a controller failure or a cable break.

**2.3.3: Digital Input**

**Three Formats**

In position mode, the drive can accept position commands via two digital inputs, using one of these signal formats: pulse and direction, count up/count down, and quadrature.

In all three formats, the drive can be configured to invert the command.

**Pulse Smoothing**

In position mode, the drive’s trajectory generator ensures smooth motion even when the command source cannot control acceleration and deceleration rates.

When using digital or analog command inputs, the trajectory generator can be disabled by setting the Max Accel limit to zero. (Note that when using the CAN bus, serial bus, or CVM Control Program, setting Max Accel to zero prevents motion.)

**Pulse and Direction Format**

In pulse and direction format, one input takes a series of pulses as motion step commands, and another input takes a high or low signal as a direction command, as shown below.

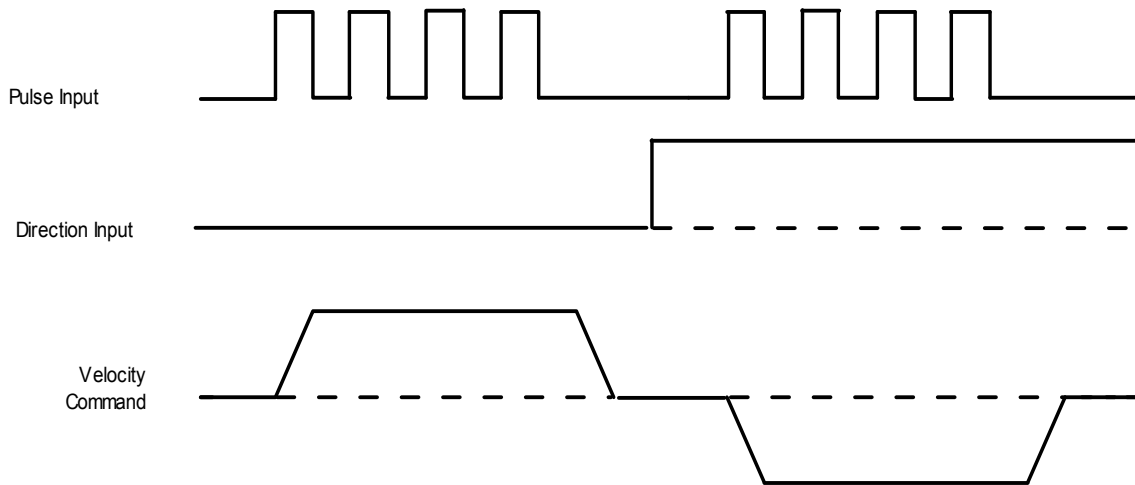

The drive can be set to increment position on the rising or falling edge of the signal. Stepping resolution can be programmed for electronic gearing.

**Count Up/Count Down Format**

In the count up/count down format, one input takes each pulse as a positive step command, and another takes each pulse as a negative step command, as shown below.

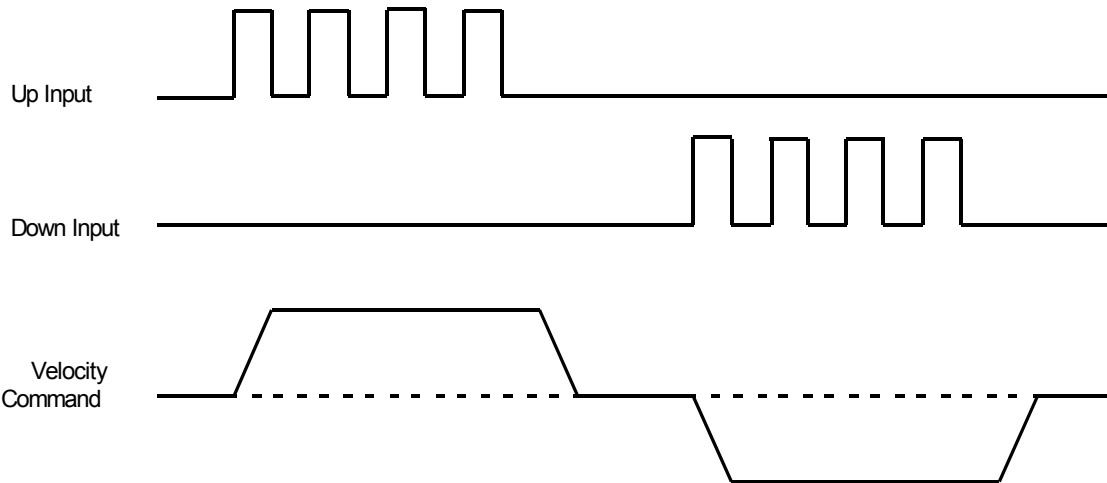

The drive can be set to increment position on the rising or falling edge of the signal. Stepping resolution can be programmed for electronic gearing.

**Quadrature Format**

In quadrature format, A/B quadrature commands from a master encoder (via two inputs) provide velocity and direction commands, as shown below.

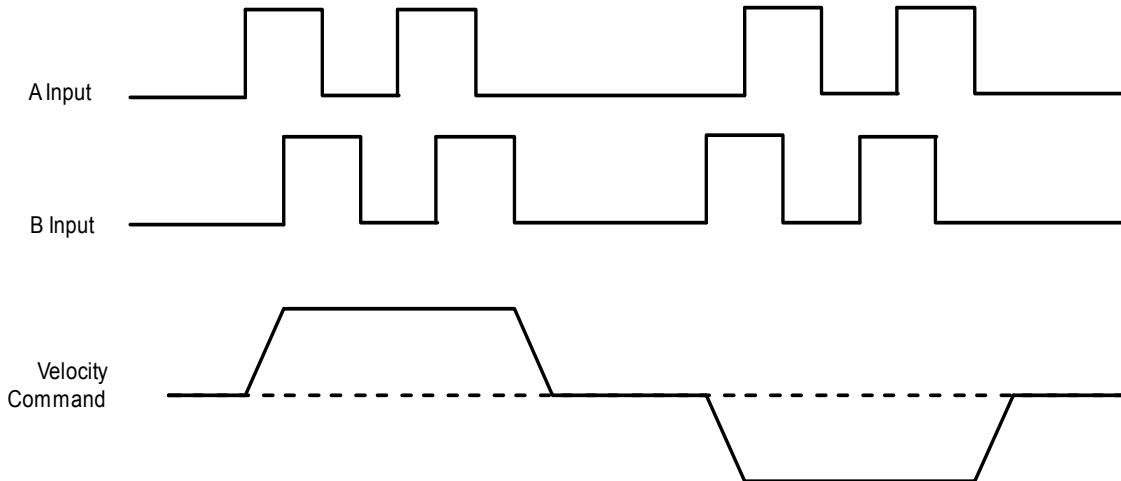

The ratio can be programmed for electronic gearing.



## 2.4: Communication

As described below, the drive features multiple communication interfaces, each used for different purposes.

Interface	Description
RS-232 port	<p>The drive features a three-wire RS-232 port. Control commands can be sent over the RS-232 port using Copley Controls ASCII interface commands.</p> <p>In addition, CME 2 software communicates with the drive (using a binary protocol) over this link for drive commissioning, adjustments, and diagnostics. For RS-232 port specifications, see <a href="#">Serial Interface (p. 76)</a>. For RS-232 port wiring instructions, see <a href="#">RS-232 Serial Communications (p. 103)</a>.</p> <p>Note that CME 2 can be used to make adjustments even when the drive is being controlled over the CAN interface or by the digital inputs .</p>
CAN interface (XPL/XP2)	When operating as a CAN node, the drive takes command inputs over a CANopen network. CAN communications are described in the next section.
EtherCAT (XEL/XE2/800-1818/800-1819)	XEL/XE2/800-1818/800-1819 accepts CANopen commands over EtherCAT.
MACRO (XML/XM2)	The XML/XM2 typically runs in torque mode accepting commands over the MACRO network. (Velocity mode is also supported.)

 <b>DANGER</b>	<p><b>Using CME 2 can affect or suspend CAN operations.</b></p>
	<p>When operating the drive as a CANopen node, use of CME 2 to change drive parameters can affect CANopen operations in progress.</p> <p>Using CME 2 to initiate motion can cause CANopen operations to suspend. The operations may restart unexpectedly when the CME 2 move is stopped.</p> <p><b>Failure to heed this warning can cause equipment damage, injury, or death.</b></p>

---

## 2.4.1: CAN Communication Details (XPL/XP2)

---

### CAN Network and CANopen Profiles for Motion

In position mode, the XPL/XP2 can take instruction over a two-wire Controller Area Network (CAN). CAN specifies the data link and physical connection layers of a fast, reliable network.

CANopen is a set of profiles (specifications) built on a subset of the CAN application layer protocol. These profiles specify how various types of devices, including motion control devices, can use the CAN network in a highly efficient manner. Xenus Plus supports the relevant CANopen profiles, allowing it to operate in the following modes of operation: profile torque, profile velocity, profile position, interpolated position, and homing.

### Supported CANopen Modes

- **Profile Position:** Mode 1  
The drive is programmed with a velocity, a relative or absolute target position, acceleration and deceleration rates. On command, a complete motion profile is executed, traveling the programmed distance or ending at the programmed position. The drive supports both trapezoidal and s-curve profiles.
- **Profile Velocity:** Mode 3  
The drive is programmed with a velocity, a direction, and acceleration and deceleration rates. When the drive is enabled, the motor accelerates to the set velocity and continues at that speed. When the drive is halted, the velocity decelerates to zero.
- **Profile Torque:** Mode 4  
The drive is programmed with a torque command. When the drive is enabled, or the torque command is changed, the motor torque ramps to the new value at a programmable rate. When the drive is halted, the torque ramps down at the same rate.
- **Homing:** Mode 6  
Used to move the axis from an unknown position to a known reference or zero point with respect to the mechanical system. The homing mode is configurable to work with a variety of combinations of encoder index, home switch, and limit switches.
- **Interpolated Position (PVT, or Position, Velocity, Time):** Mode 7  
The controller sends the drive a sequence of points, each of which is a segment of a larger, more complex move, rather than a single index or profile. The drive then uses cubic polynomial interpolation to “connect the dots” so that the motor reaches each point at the specified velocity at the programmed time.

**CANopen Architecture**

As shown below, in a CANopen motion control system, control loops are closed on the individual drives, not across the network. A master application coordinates multiple devices, using the network to transmit commands and receive status information. Each device can transmit to the master or any other device on the network. CANopen provides the protocol for mapping device and master internal commands to messages that can be shared across the network.

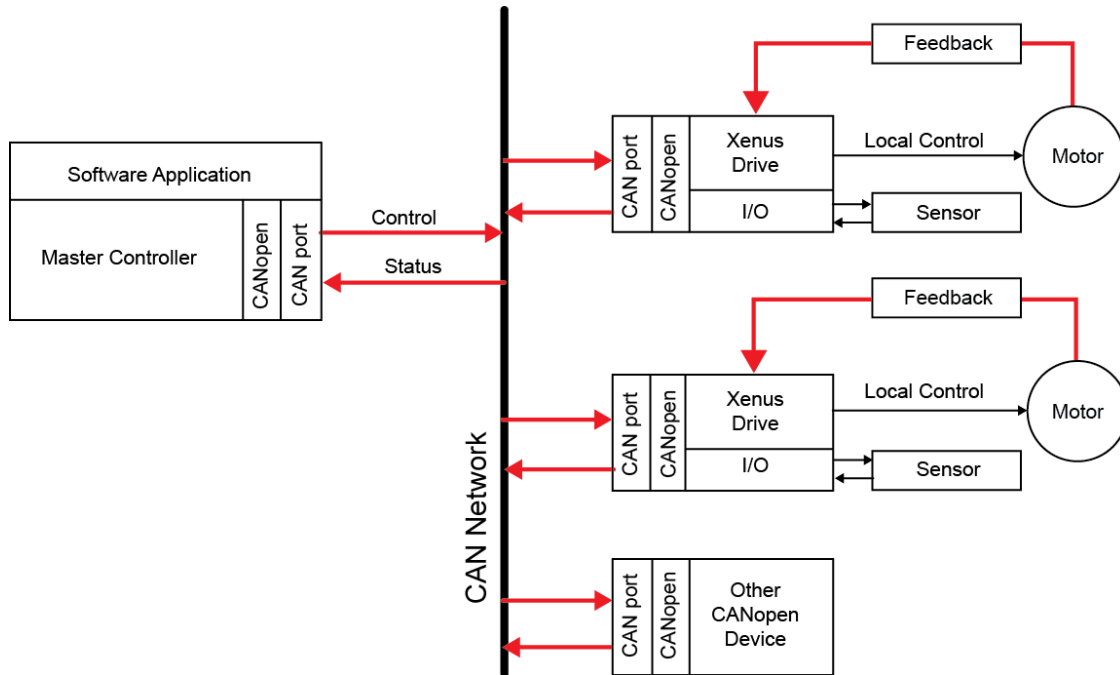

**CAN Addressing**

A CANopen network can support up to 127 nodes. Each node must have a unique and valid seven-bit address (Node ID) in the range of 1-127. (Address 0 is reserved and should only be used when the drive is serving as a CME 2 serial port multi-drop gateway.)

There are several basic methods for setting the CAN address, as described below. These method can be used in any combination, producing a CAN address equal to the sum of the settings.

Addressing Method	Description
Use switch	If the address number <= 15, CAN address can be set using the CAN ADDR switch only.
Use inputs	Use the drive's programmable digital inputs (user selects how many (1-7) and which inputs are used).
Use programmed value	Program address into flash only.

For more information on CAN addressing, see the *CME 2 User Guide*.

For more information on CANopen operations, see the following Copley Controls documents:

- *CANopen Programmer's Manual*
- *CML Reference Manual*
- *CMO (Copley Motion Objects) Programmer's Guide*

**2.4.2: EtherCAT Communication Details (XEL/XE2/800-1818/800-1819)**

The XEL/XE2/800-1818/800-1819 models accept CAN application layer over EtherCAT (CoE) commands.

EtherCAT supports two types of addressing nodes on the network: auto-increment and fixed. Nodes on an EtherCAT network are automatically addressed by their physical position on the network. The first drive found on the network is address -1(0xFFFF). The second is -2 (0xFFFE), and so on.

Fixed addresses are assigned by the master when it scans the network to identify all of the nodes and are independent of the physical position on the network. Fixed addresses begin with 1001 (0x3E9) and increment thereafter as nodes are found. Each dual axis drive is addressed as a single physical node on the EtherCAT network having two axes of motion.

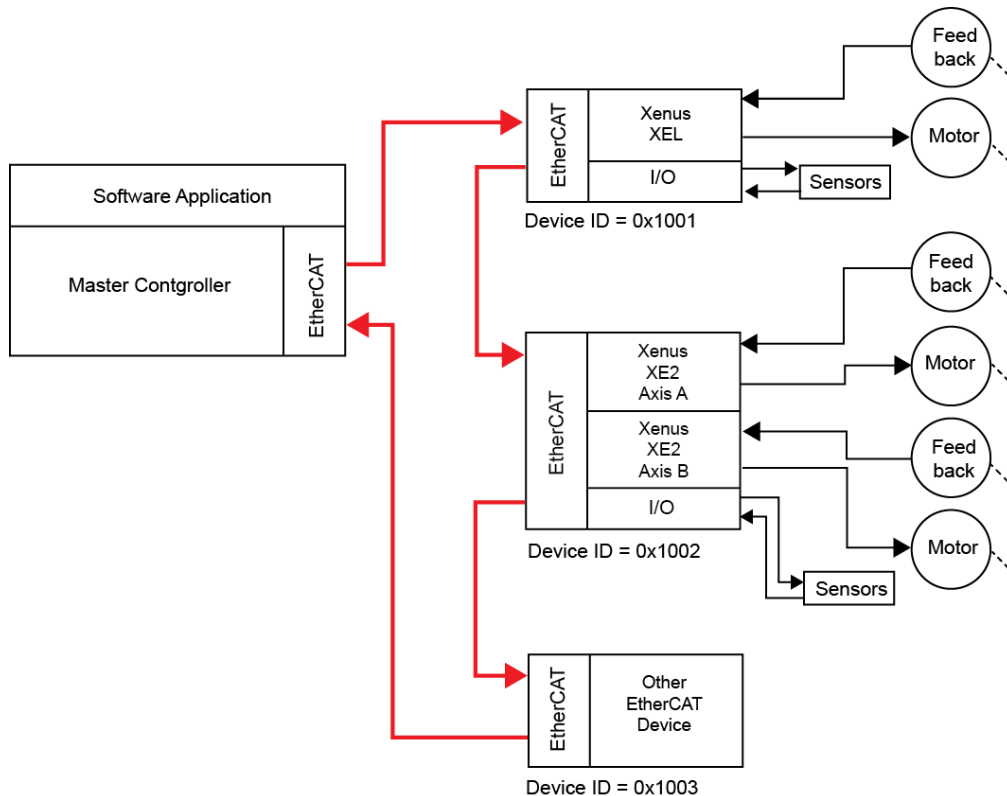

As an alternate to the default addressing, switches S1 and S2 may be used to program a drive's Device ID, or Station Alias with a value between 0x01 and 0xFF (1-255 decimal). In dual axis drives the second drive follows the first's Device ID value. Use of a station alias guarantees that a given drive can be accessed absolutely independent of the cabling configuration.

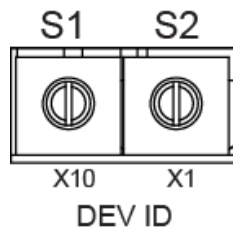

The fixed address and station alias are always available. If the switch-based station alias is used, it is the responsibility of the user to ensure that each drive has a unique station alias.

**2.4.3: MACRO Communication Details (XML/XM2)**

The XML/XM2 typically runs in torque mode accepting commands over the MACRO network. (Velocity mode is also supported.)

**MACRO Addressing**

A MACRO network, or ring for the XML/XM2 can have up to sixteen master controllers with hex addresses from 0x00 to 0x0F. Each master can control up to eight servo drives. This works out to a maximum of 128 servo drives on a MACRO ring.

A MACRO address is eight bits long. Switch S1 controls bits 7~4 to select the MACRO master and switch S2 controls bits 3~0 and selects the node address. Node addresses available for servo drives are: 0~1, 4~5, 8~9, and 12~13. With the 2-axis XM2, the valid node addresses are: 0, 4, 8, and 12. These address Axis A of the servo drives. Axis B of the drives can then be addressed by adding 1 to the address set by node switch S2.

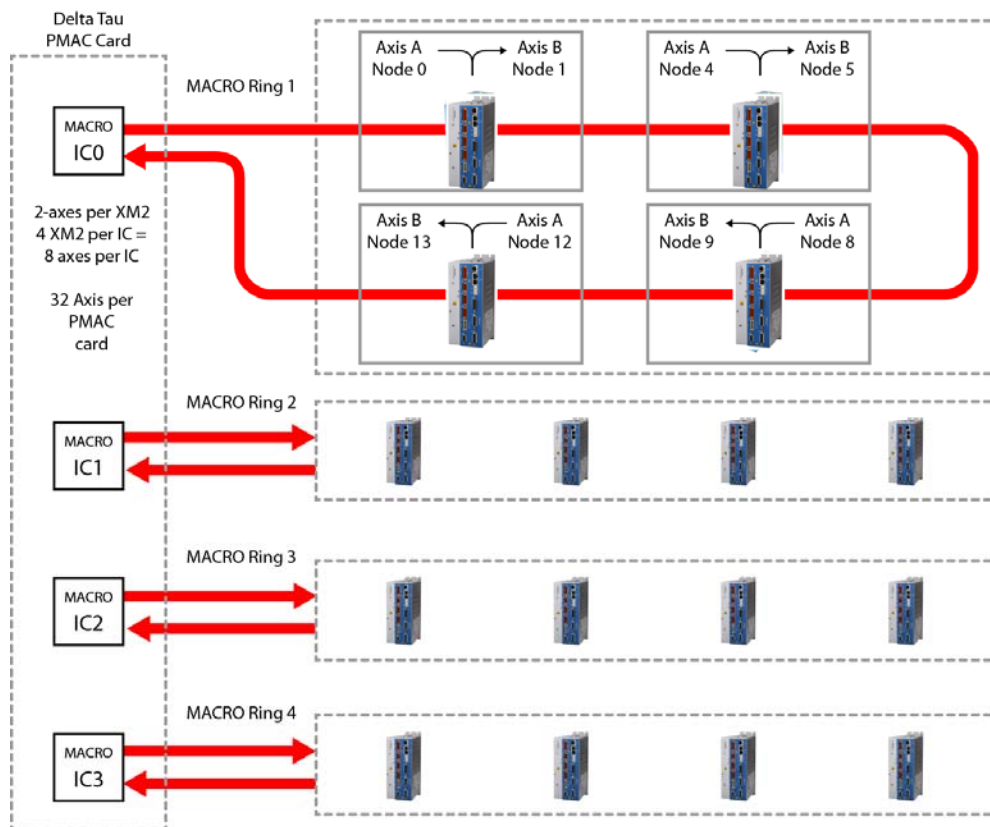

**2.4.4: PWM Switching Frequency Synchronizing**

In some situations, such as when sampling small analog signals, it is desirable to synchronize the PWM switching frequency among multiple drives. In these cases, one drive serves as a master for one or more slave drives.

The distributed clock feature of EtherCAT or the Time function in CANopen can be used to establish PWM switching frequency synchronization among the network connected drives.

Note that when the STO function is active, there is no PWM switching or current at the drive motor outputs. See [Safe Torque Off \(p. 50\)](#).

## 2.5: Status Indicators

### 2.5.1: XEL J6 STAT & NET: Drive and EtherCAT State Machine Indicators

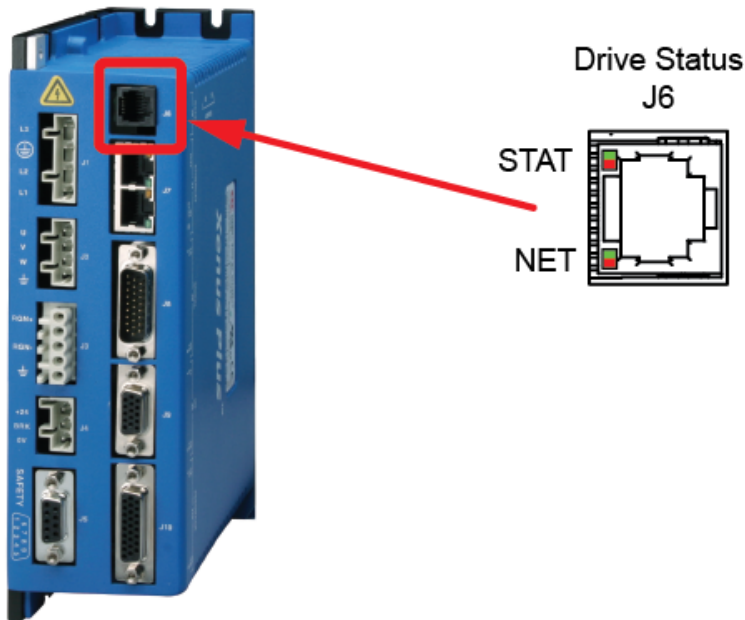

#### XEL J6 STAT Indicator: Drive Status

XEL Drive status indicator color/blink codes are described below.

Color/Blink Code	Meaning
Not illuminated	No +24 Vdc power to drive.
Steady green	Drive is enabled and operational.
Slow-blinking green	Drive is disabled. No faults or warnings are active.
Fast-blinking green	A limit switch is active. The drive is enabled.
Green flash twice followed by a pause	STO is active, One or both STO inputs are de-energized. The drive is hardware & software enabled but the PWM outputs cannot produce current in the motor when STO is active.
Steady red	A non-latched fault has occurred.
Blinking red	A latched fault has occurred.

#### XEL J6 NET Indicator: EtherCAT State Machine

Run (Green)	
Color/Blink Code	Meaning
Not illuminated	Initialization
Blinking	Pre-operational.
Single flash	Safe-operational.
Steady	Operational.
Error (Red)	
Not illuminated	No error.
Blinking	Invalid configuration. A change of state commanded by the master is not possible or is illegal.
Single flash	Local error. The slave has initiated a change of state by itself in response to an error.
Double flash	Watchdog timeout. The EtherCAT sync manager watchdog timer has timed out.

**2.5.2: XEL J7: EtherCAT Network Status Indicators**

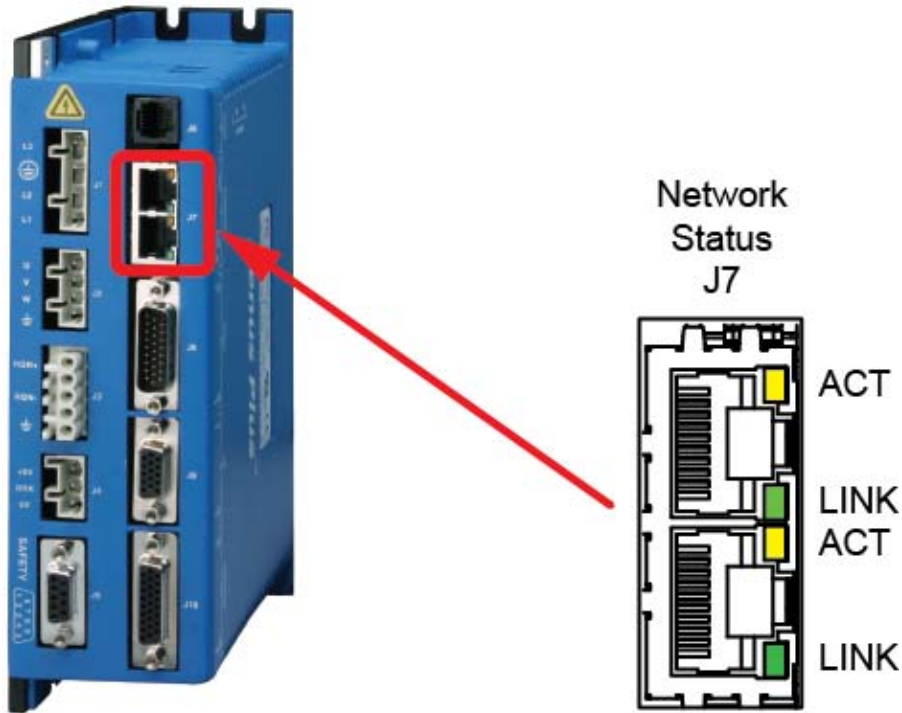

**XEL J7 LINK and ACT Indicators: EtherCAT Network Status**

LINK shows the state of the physical link (network). ACT shows activity on the network.

<b>LINK (Green)</b>	<b>ACT (Yellow)</b>	<b>Description</b>
On	Off	Port open, no activity
On	Flicker	Port open, network activity
Off	On	Port closed

**2.5.3: XE2/800-1818/800-1819 J7 Axis A/B: Drive Status Indicators**

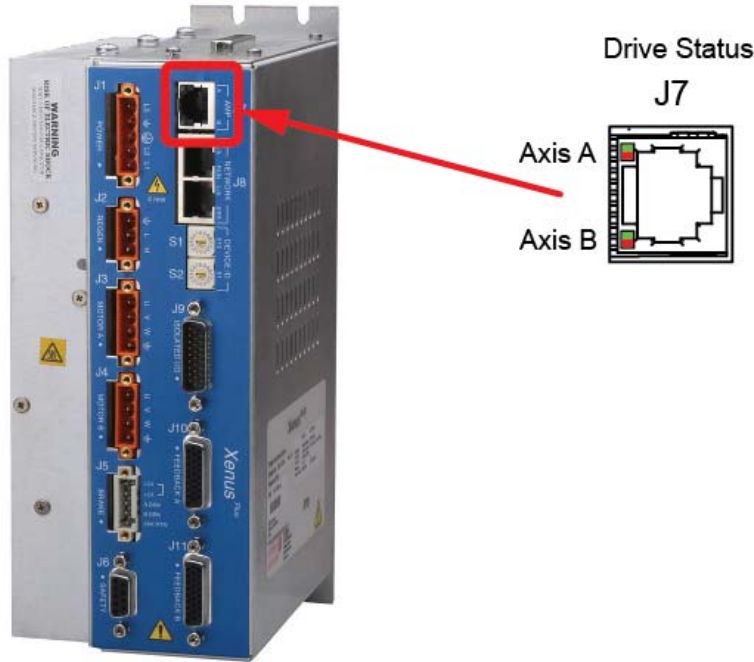

**XE2/800-1818/800-1819 J7 Axis A/B Drive Status Indicators**

XE2/800-1818/800-1819 indicator color/blink codes are described below.

<b>Color/Blink Code</b>	<b>Meaning</b>
Green/Solid	Drive OK and enabled. Will run in response to reference inputs or EtherCAT commands.
Green/Slow Blinking	Drive OK but NOT-enabled. Will run when enabled.
Green/Fast Blinking	Positive or Negative limit switch active. Drive will only move in direction not inhibited by limit switch.
Green flash twice followed by a pause	STO is active, One or both STO inputs are de-energized. The drive is hardware & software enabled but the PWM outputs cannot produce current in the motor when STO is active.
Red/Solid	Transient fault condition. Drive will resume operation when fault is removed.
Red/Blinking	Latching fault. Operation will not resume until fault is cleared or drive is Reset.



**2.5.4: XE2/800-1818/800-1819 J8 Network Status Indicators**

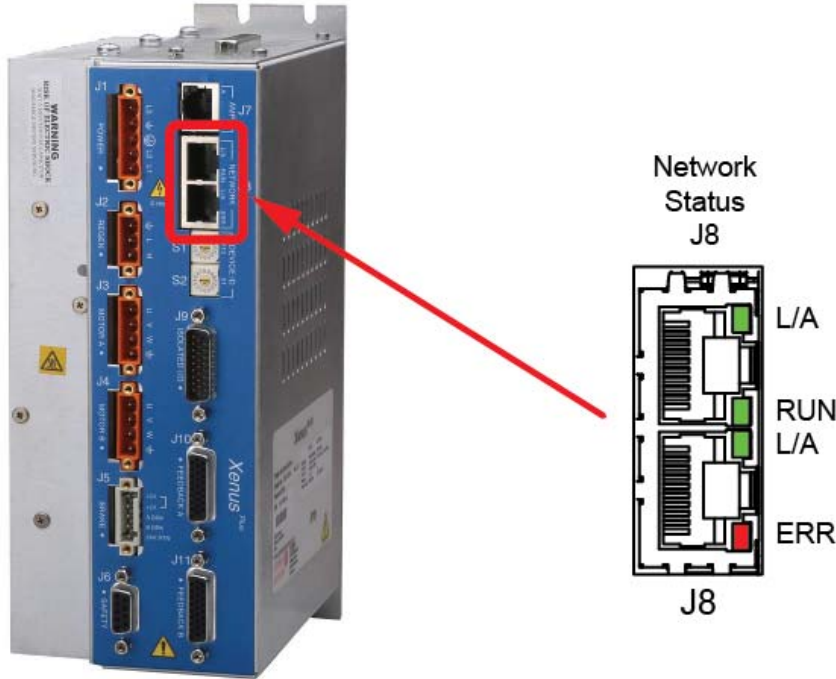

**XE2/800-1818/800-1819 J8 L/A Indicators**

Shows the state of the physical link and activity on the link.

L/A (Green)	Meaning
Off	No link
On	Port open, no activity
On and flickering	Port open and activity

**XE2/800-1818/800-1819 J8 RUN Indicator**

Indicates the state of the ESM (EtherCAT state machine)

RUN (Green)	Meaning
Off	Init
Blinking	Pre-operational
Single flash	Safe-operational
On	Operational

**XE2/800-1818/800-1819 J8 ERR Indicator**

Indicates that errors have occurred on the EtherCAT drive or network

ERR (Red)	Meaning
Off	EtherCAT communications are working correctly.
Blinking	Invalid configuration, general configuration error.
Single flash	Local error, slave has changed EtherCAT state autonomously.
Double flash	PDO or EtherCAT watchdog timeout, or an application watchdog timeout has occurred,

**2.5.5: XML J6: Drive and MACRO Network Status Indicators**

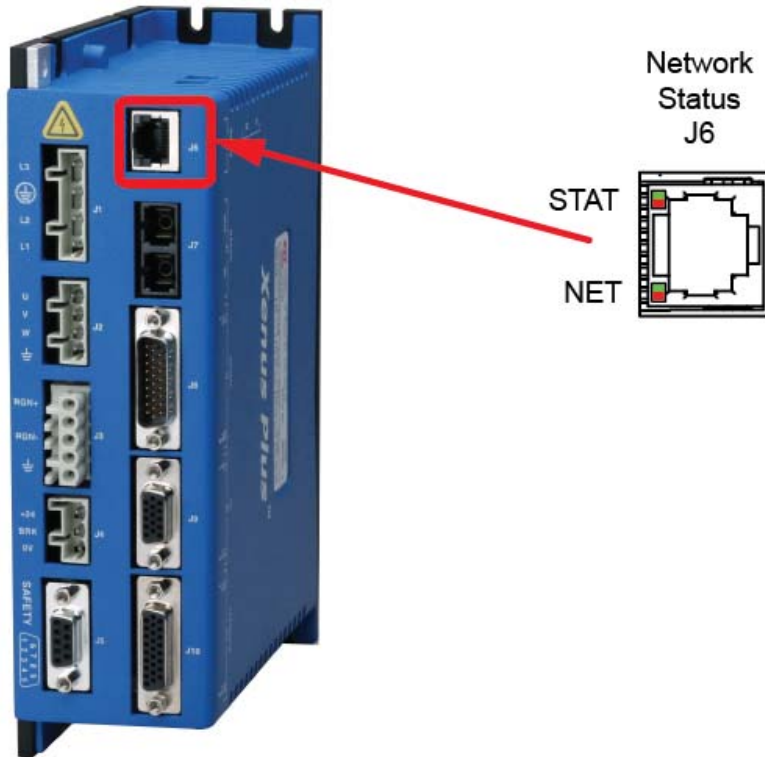

**XML J6 STAT Indicator: Drive Status**

Indicator color/blink codes are described below.

Color/Blink Code	Meaning
Not illuminated	No +24 Vdc power to drive.
Steady green	Drive is enabled and operational.
Slow-blinking green	Drive is disabled. No faults or warnings are active.
Fast-blinking green	A limit switch is active. The drive is enabled.
Green flash twice followed by a pause	STO is active, One or both STO inputs are de-energized. The drive is hardware & software enabled but the PWM outputs cannot produce current in the motor when STO is active.
Steady red	A non-latched fault has occurred.
Blinking red	A latched fault has occurred.

**XML J6 NET Indicator: MACRO Network Status**

NET	Description
Off	MACRO network has not been detected.
Blinking green	MACRO network detected and has disabled drive.
Green	MACRO network detected and is trying to enable drive. This condition can occur while the AMP LED shows any of its valid color combinations.
Steady red	MACRO network errors have been detected.

2.5.6: XM2 J7: Drive and MACRO Network Status Indicators

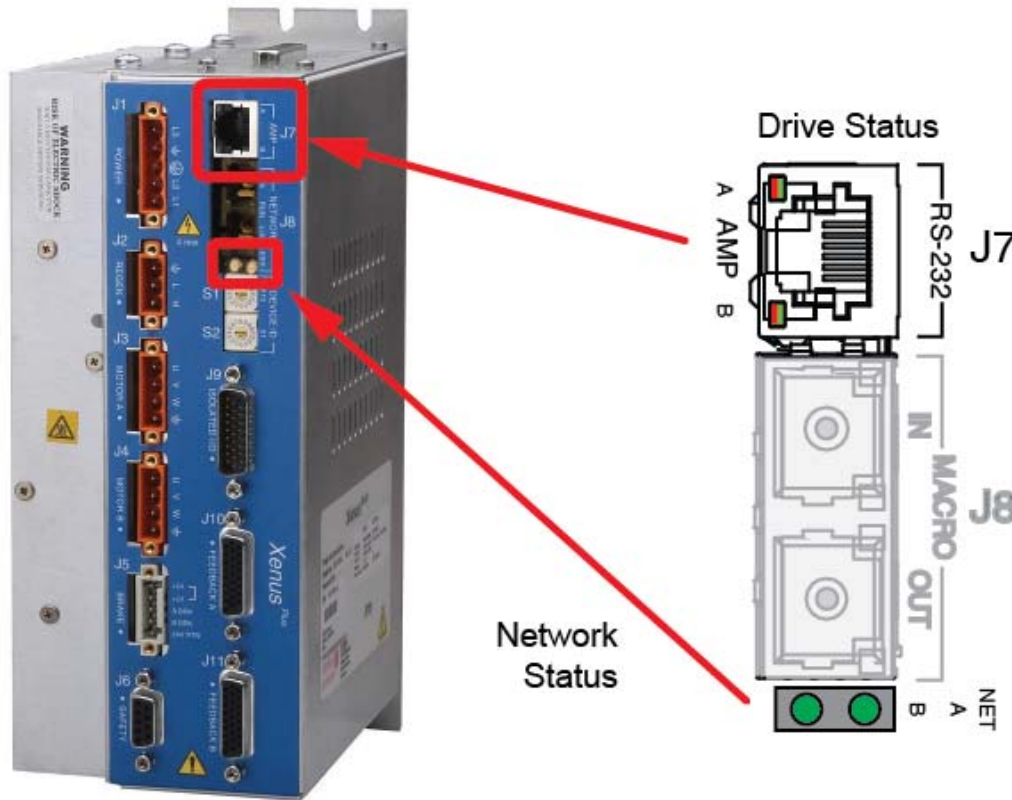

**XM2 J7 Axis A/B: Drive Status (AMP) Indicators**

XM2 indicator color/blink codes are described below.

Color/Blink Code	Meaning
Green/Solid	Drive OK and enabled. Will run in response to reference inputs or MACRO commands.
Green/Slow Blinking	Drive OK but NOT-enabled. Will run when enabled.
Green/Fast Blinking	Positive or Negative limit switch active. Drive will only move in direction not inhibited by limit switch.
Green flash twice followed by a pause	STO is active, One or both STO inputs are de-energized. The drive is hardware & software enabled but the PWM outputs cannot produce current in the motor when STO is active.
Red/Solid	Transient fault condition. Drive will resume operation when fault is removed.
Red/Blinking	Latching fault. Operation will not resume until fault is cleared or drive is Reset.

**XM2 J8 Axis A/B NET Indicator: MACRO Network (NET) Status**

NET	Description
Off	MACRO network has not been detected.
Blinking green	MACRO network detected and has disabled drive.
Green	MACRO network detected and is trying to enable drive. This condition can occur while the AMP LED shows any of its valid color combinations. This LED must be green for the AMP LED to become green.
Steady red	MACRO network errors have been detected.

**2.5.7: XPL J6 STAT: Drive Status Indicator**

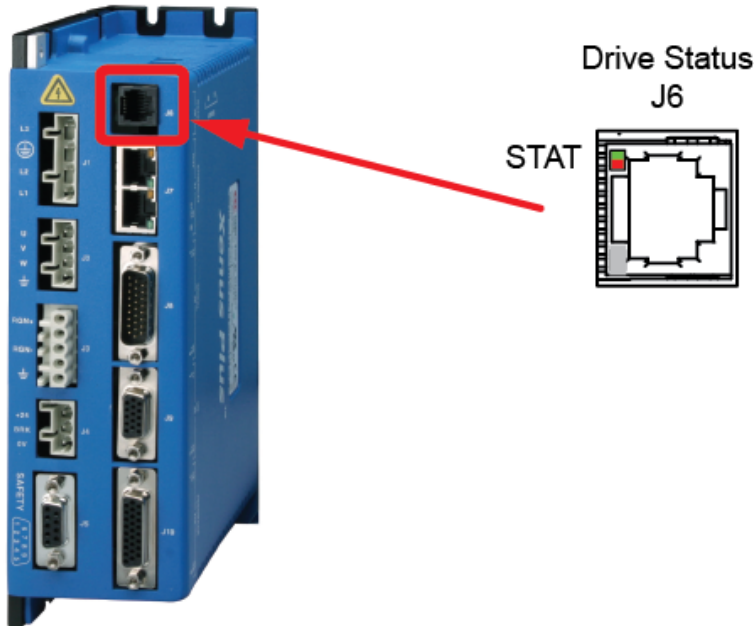

**XPL J6 STAT Indicator**

XPL Drive status indicator color/blink codes are described below.

<b>Color/Blink Code</b>	<b>Meaning</b>
Not illuminated	No +24 Vdc power to drive.
Steady green	Drive is enabled and operational.
Slow-blinking green	Drive is disabled. No faults or warnings are active.
Fast-blinking green	A limit switch is active. The drive is enabled.
Green flash twice followed by a pause	STO is active, One or both STO inputs are de-energized. The drive is hardware & software enabled but the PWM outputs cannot produce current in the motor when STO is active.
Steady red	A non-latched fault has occurred.
Blinking red	A latched fault has occurred.

**XPL J6 NET Indicator: CANopen RUN and ERR States**

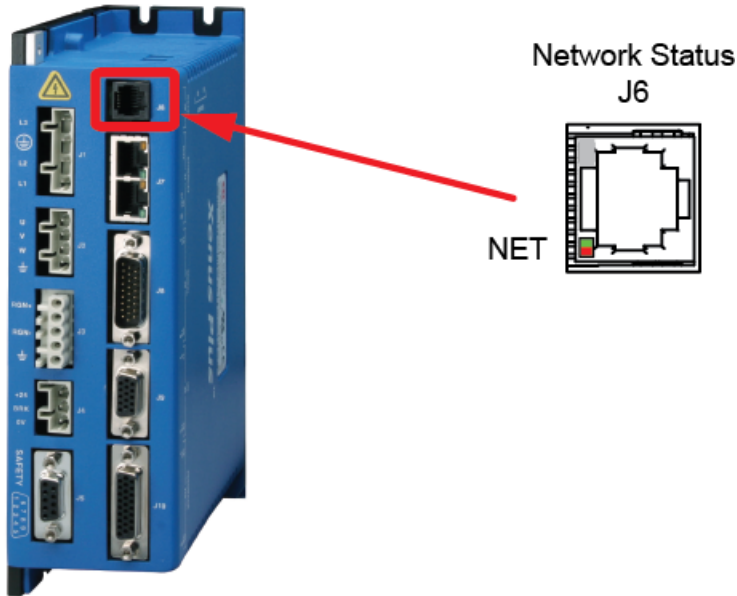

The color/blink codes of the NET indicator on J6 comply with CAN Indicator Specification CiA 303-3 as shown on the following pages. Green is the RUN state and red is the ERR state. Note that green and red codes alternate, each indicating a different set of conditions.

The red/green ACT/ERR LEDs indicate the status of the physical layer. The green ACT LED indicates physical connection and activity. No connection or network errors show the red ERR LED. In addition, these are turned off when the CAN node ID selector (CAN ADDR) is set to 0. A setting of 0, which is invalid, shuts down most operations on the CAN interface, and the LEDs are shut off to indicate this status.

XPL J6 NET Indicator: CANopen RUN and ERR States

<b>RUN (Green) LED: CANopen State Machine Mode of Operation</b>		
<b>Indicator</b>	<b>State</b>	<b>Diagram</b>
Blinking green	Pre-operational.	
Steady green	Operational	
Single flash green	Stopped	

<b>ERR (Red) LED: CANopen Physical Layer Status</b>		
Single flash red	Warning Limit Reached	
Double flash red	Error Control Event	
Triple flash red	Sync Error	
Steady red	Bus Off	

**2.5.8: XPL J7 Activity/Error: CAN Network Activity and Errors**

**For firmware versions before V2.0:**

Both LEDs blink in unison: Green = receive data, Red = transmit data

ACT Indicator	State
Blinking red	Normal transmit/receive data on the network

**For firmware version V2.0 and higher:**

Both LEDs blink in unison to show bus activity and low-level bus errors.

ACT Indicator	State
Blinking green	Normal transmit/receive data on the network
Blinking red	Low-level CAN bus errors: <ul style="list-style-type: none"> <li>• Bit Error</li> <li>• Stuff Error</li> <li>• CRC Error</li> <li>• Form Error</li> <li>• Acknowledgment Error</li> </ul> Reference Bosch CAN Specification Version 2.0 for details

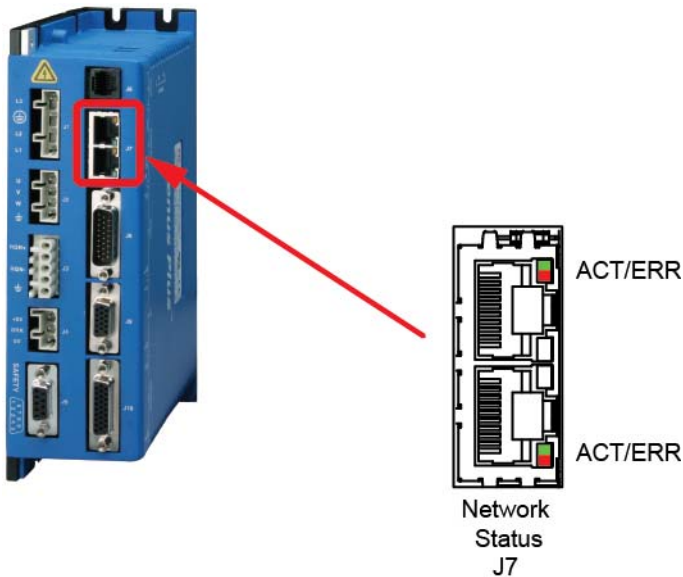

**2.5.9: XP2 J7 Axis A/B: Drive Status Indicators**

The LEDs located on connector J7 indicate axis A and B drive status.

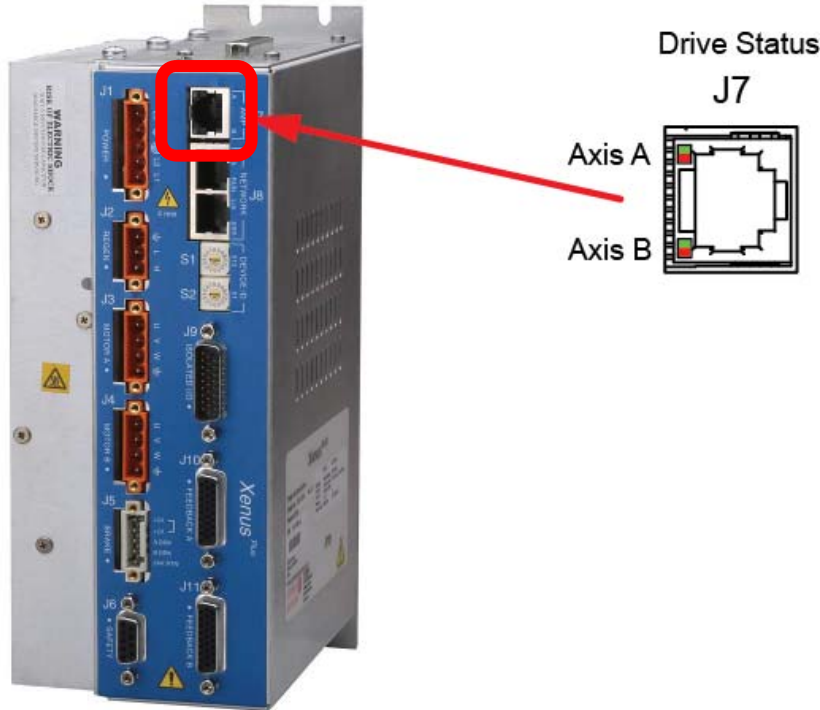

**XP2 J7 Axis A/B: Drive Status Indicators**

XP2 indicator color/blink codes are described below.

<b>Color/Blink Code</b>	<b>Meaning</b>
Green/Solid	Drive OK and enabled. Will run in response to reference inputs or CANopen commands.
Green/Slow Blinking	Drive OK but NOT-enabled. Will run when enabled.
Green/Fast Blinking	Positive or Negative limit switch active. Drive will only move in direction not inhibited by limit switch.
Green flash twice followed by a pause	STO is active, One or both STO inputs are de-energized. The drive is hardware & software enabled but the PWM outputs cannot produce current in the motor when STO is active.
Red/Solid	Transient fault condition. Drive will resume operation when fault is removed.
Red/Blinking	Latching fault. Operation will not resume until fault is cleared or drive is Reset.



2.5.10: XP2 J8 RUN, ERR, & L/A Indicators

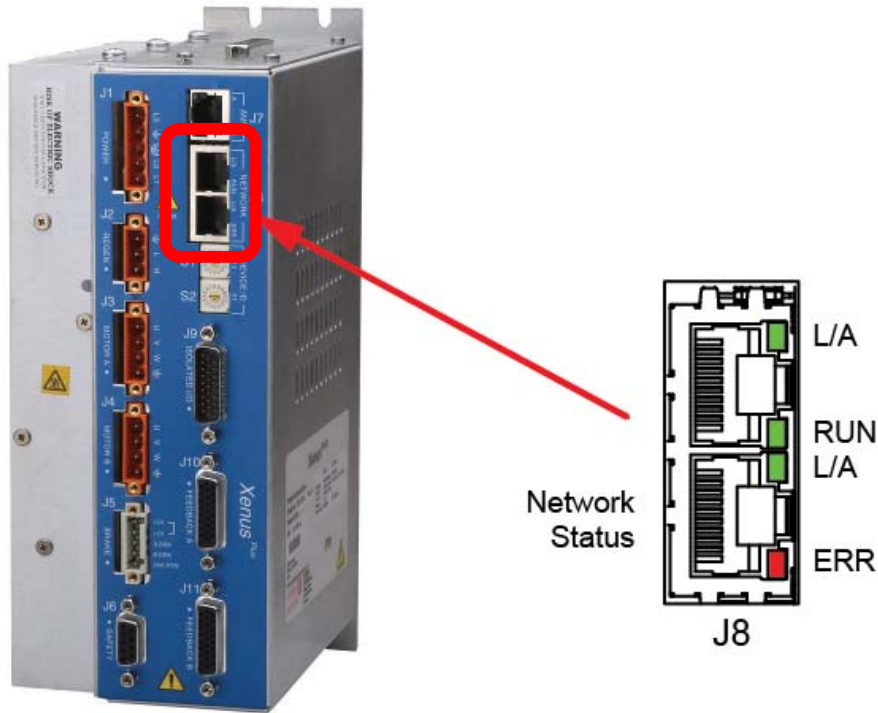

**XP2 J8 L/A Indicators**

Shows the state of the physical link and activity on the link.

L/A (Green)	Meaning
Off	No link
On	Port open, no activity
On and flickering	Port open and activity

**XP2 J8 RUN Indicator**

Indicates the state of the CANOpen state machine

RUN (Green)	Meaning
Blinking	Pre-operational
Single flash	Stopped
On	Operational

**XP2 J8 ERR Indicator**

Indicates that errors have occurred on the CANOpen drive or network

ERR (Red)	Meaning
Single flash red	Warning Limit Reached
Double flash red	Error Control Event
Triple flash red	Sync Error
Steady red	Bus Off

## 2.6: Protection

### 2.6.1: Safe Torque Off

All of the Xenus Plus models provide a Safe Torque Off (STO) function. Two inputs are provided which, when de-energized, prevent the upper and lower devices in the PWM outputs from being operated by the digital control core. This provides a positive OFF capability that cannot be overridden by the control firmware, or associated hardware components. When the inputs are energized (current is flowing through the input diodes), the control core will be able to control the on/off state of the PWM outputs. Although all models have the STO feature, there are important differences in the STO design between the single axis (XEL/XPL/XML) and the dual axis (XE2/XP2/XM2/800-1818/800-1819) versions.

The STO circuit in the single axis models was designed using guidance from IEC 61800-5-2, an international standard that specifies requirements for motor drive functional safety features including STO.

The STO feature in the dual axis models was developed in accordance with several functional safety standards and has both SIL and Category/Performance Level ratings. The design and development of the STO feature on these models are being submitted to TÜV SÜD for approval. Pending such approval the XE2/XP2/XM2/800-1818/800-1819 products will bear the TÜV SÜD Functional Safety mark. For more information on STO for the Xenus Plus Dual Axis models, see the *Xenus Plus Dual-Axis STO Manual*

### 2.6.2: Faults

#### Overview

Xenus Plus detects and responds to a set of conditions regarded as faults, such as drive over temperature and excessive following error. When any fault occurs, with the exception of a following error, the drive's PWM output stage is disabled, the fault type is recorded in the drive's internal error log (which can be viewed with CME 2), and the status LED changes to indicate a fault condition exists. A digital output can also be programmed to activate on a fault condition. The following error fault behaves with slight differences, as described in [Following Error Fault Details \(p.53\)](#)

The drive's PWM output stage can be re-enabled after the fault condition is corrected and the drive faults are cleared. The process for clearing faults varies depending on whether the fault is configured as non-latched or latched. The fault-clearing descriptions below apply to all faults except for the following error fault, which is described in [Following Error Fault Details \(p.53\)](#)

#### Clearing Non-Latched Faults

The drive clears a non-latched fault, without operator intervention, when the fault condition is corrected.

 <b>DANGER</b>	<b>Risk of unexpected motion with non-latched faults.</b>
	<p>After the cause of a non-latched fault is corrected, the drive re-enables the PWM output stage without operator intervention. In this case, motion may re-start unexpectedly. Configure faults as latched unless a specific situation calls for non-latched behavior. When using non-latched faults, be sure to safeguard against unexpected motion.</p> <p><b>Failure to heed this warning can cause equipment damage, injury, or death.</b></p>

**Clearing Latched Faults**

A latched fault is cleared only after the fault has been corrected and at least one of the following actions has been taken:

- Power-cycle the +24 Vdc to the drive
- Cycle (disable and then enable) an enable input that is configured as Enables with Clear Faults or Enables with Reset
-  Access the CME 2 Control Panel and press Clear Faults or Reset
- Clear the fault over the CANopen network or serial bus

**Example: Non-Latched vs. Latched Faults**

For example, the drive temperature reaches the fault temperature level and the drive reports the fault and disables the PWM output. Then, the drive temperature is brought back into operating range. If the Drive Over Temperature fault is not latched, the fault is automatically cleared and the drive’s PWM outputs are enabled. If the fault is latched, the fault remains active and the drive’s PWM outputs remain disabled until the faults are specifically cleared (as described above).

**Fault Descriptions**

- The set of possible faults is described below. For details on limits and ranges, see [Fault Levels \(p. 78\)](#)

<b>Fault Description</b>	<b>Fault Occurs When...</b>	<b>Fault is Corrected When...</b>
*Drive Over Temperature	Drive’s internal temperature exceeds specified temperature.	Power module temperature falls below specified temperature.
Motor Phasing Error	Encoder-based phase angle does not agree with Hall switch states. This fault can occur only with brushless motors set up using sinusoidal commutation. It does not occur with resolver feedback or with Halls correction turned off.	Encoder-based phase angle agrees with Hall switch states.
*Feedback error	Over current condition detected on the output of the internal +5 Vdc supply used to power the feedback. Resolver or analog encoder not connected or levels out of tolerance.	Encoder power returns to specified voltage range. Feedback signals stay within specified levels.
*Motor Over Temperature	Motor over-temperature switch changes state to indicate an over-temperature condition.	Temperature switch changes back to normal operating state.
Under Voltage	Bus voltage falls below specified voltage limit.	+ DC bus voltage returns to specified voltage range.
Over Voltage	Bus voltage exceeds specified voltage limit.	+ DC bus voltage returns to specified voltage range.
*Following Error	User set following error threshold exceeded.	See <a href="#">Position and Velocity Errors (p. 52)</a> .
*Short Circuit Detected	Output to output, output to ground, internal PWM bridge fault.	Short circuit has been removed.
oOver Current (Latched)	Output current I <sup>2</sup> T limit has been exceeded.	Drive is reset and re-enabled.
*Latched by default.		

## 2.7: Position and Velocity Errors

### 2.7.1: Error-Handling Methods

---

In position mode, any difference between the limited position output of the trajectory generator and the actual motor position is a position error. The drive's position loop uses complementary methods for handling position errors: following error fault, following error warning, and a position-tracking window.

Likewise, in velocity or position mode, any difference between the limited velocity command and actual velocity is a velocity error. The drive's velocity loop uses a velocity tracking window method to handle velocity errors. (There is no velocity error fault.)

### 2.7.2: Following Error Faults

---

When the position error reaches the programmed fault threshold, the drive immediately faults. (The following error fault can be disabled.)

For detailed information, see [Following Error Fault Details](#) (p.53).

### 2.7.3: Following Error Warnings

---

When the position error reaches the programmed warning threshold, the drive immediately sets the following error warning bit in the status word. This bit can be read over the CAN network. It can also be used to activate a digital output.

### 2.7.4: Position and Velocity Tracking Windows

---

When the position error exceeds the programmed tracking window value, a status word bit is set. The bit is not reset until the position error remains within the tracking window for the programmed tracking time.

A similar method is used to handle velocity errors.

For detailed information, see [Tracking Window Details](#) (p. 54).

## 2.7.5: Following Error Fault Details

---

### Position Error Reaches Fault Level

As described earlier, position error is the difference between the limited position output of the trajectory generator and the actual position. When position error reaches the programmed Following Error Fault level, the drive faults (unless the following error fault is disabled.) As with a warning, a status bit is set. In addition, the fault is recorded in the error log.

Additional responses and considerations depend on whether the fault is non-latched or latched, as described below.

### Drive Response to Non-Latched Following Error Fault

When a non-latched following error fault occurs, the drive drops into velocity mode and applies the Fast Stop Ramp deceleration rate to bring the motor to a halt. The drive PWM output stage remains enabled, and the drive holds the velocity at zero, using the velocity loop.

### Resuming Operations After a Non-Latched Following Error Fault

The clearing of a non-latched following error depends on the drive's mode of operation. Issuing a new trajectory command over the CAN bus or the ASCII interface, will clear the fault and return the drive to normal operating condition.

If the drive is receiving position commands from the digital or differential inputs, then the drive must be disabled and then re-enabled using the drive's enable input or through software commands. After re-enabling, the drive will operate normally.

### Drive Response to a Latched Following Error Fault

When a latched following error fault occurs, the drive disables the output PWM stage without first attempting to apply a deceleration rate.

### Resuming Operations After a Latched Following Error Fault

A latched following error fault can be cleared using the steps used to clear other latched faults:

- Power-cycle the +24 Vdc to the drive
- Cycle (disable and then enable) an enable input that is configured as Enables with Clear Faults or Enables with Reset
-  Access the CME 2 Control Panel and press Clear Faults or Reset
- Clear the fault over the CANopen network or serial bus

### 2.7.6: Tracking Window Details

#### Proper Tracking Over Time

As described earlier, position error is the difference between the limited position output of the trajectory generator and the actual position. Velocity error is the difference between commanded and actual velocity.

When the position or velocity error exceeds the programmed tracking window value, a status word bit is set. The bit is not reset until the error remains within the tracking window for the programmed tracking time.

#### Velocity Tracking Illustration

The following diagram illustrates the use of tracking window and time settings in velocity mode.

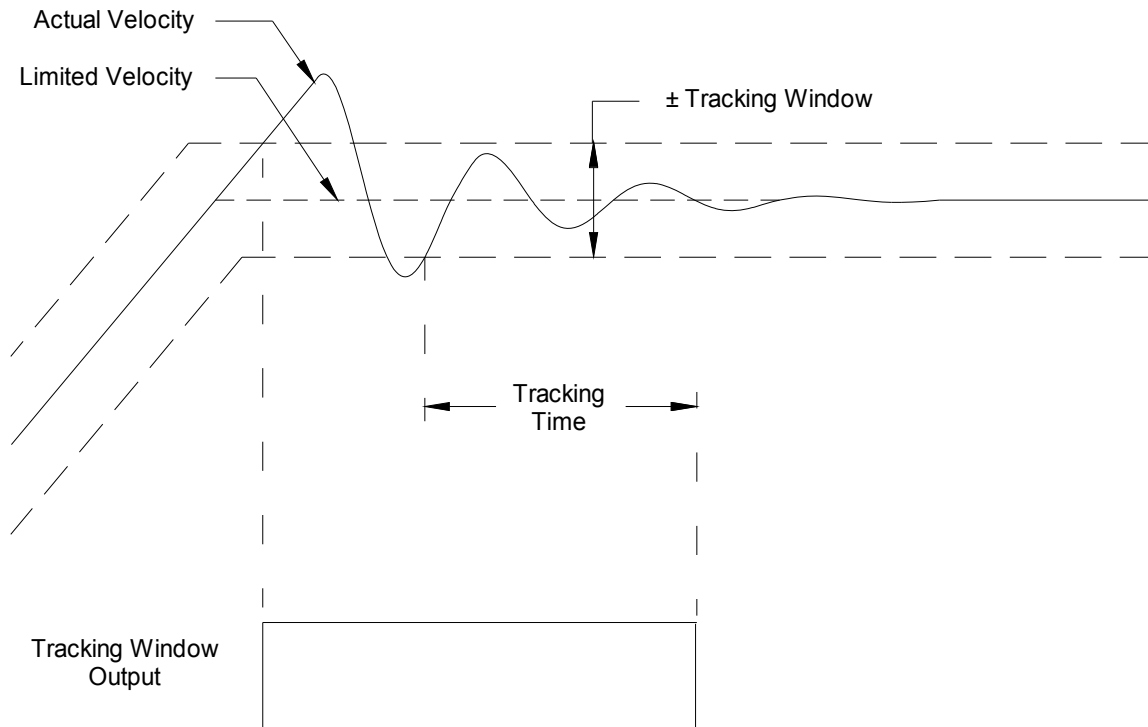

## 2.8: Inputs XEL/XPL/XML

The Xenus Plus XEL, XPL and XML drives have 15 digital inputs and 3 analog inputs.

### 2.8.1: Digital Inputs

---

The Xenus Plus XEL, XPL and XML drives feature 14 programmable digital inputs. Non-isolated inputs IN1-IN6 are connected on J8. Opto-isolated IN7-IN14 are connected on J9. IN3-IN6 are single ended or differential programmable inputs.

The IN15 digital input on J10 is for an encoder fault signal on. For a list of input functions, see the *CME 2 User Guide*.

#### Input Filters

Two types of input RC filters are used: GP (general-purpose) and HS (high-speed). Input reference functions such as Pulse and Direction, Pulse Up/Pulse Down, and Quadrature A/B are wired to inputs that have the HS filters, and inputs with the GP filters are used for general-purpose logic functions, limit switches, and the motor temperature sensor.

#### Debounce Time

To prevent undesired multiple triggering caused by switch bounce upon switch closures, each input can be programmed with a debounce time. The programmed time specifies how long an input must remain stable at a new state before the drive recognizes the state. The debounce time is ignored if the input is used as a digital command input.

#### Configure for Pull Up/Pull Down Resistors by Groups

Pre-defined groups of inputs can be programmed to have either an internal pull up or pull down resistor. See [J8 Pin Description](#) (p. 107) for groupings.

### 2.8.2: Analog Inputs

---

Two programmable differential analog inputs, AIN1 and AIN2, are connected on J8 with  $\pm 10$  Vdc range. As a reference input [AIN1] can take position/velocity/torque commands from a controller. The second input [AIN2] is programmable for other functions. The ratio of drive output current or velocity vs. reference input voltage is programmable.

Analog input [AIN3] Motemp is for use with a motor over temperature switch or sensor connected on J10.

## 2.9: Inputs XE2/XP2/XM2/800-1818/800-1819

The XE2, XP2, XM2 and 800-1818 drives have 22 digital inputs and 2 analog inputs. The 800-1819, a custom version of the XE2, has 20 digital inputs and 2 analog inputs

### 2.9.1: Digital Inputs

IN1 & IN11 are general purpose Schmitt trigger single ended inputs with programmable pull-up/down to +5 Vdc/ground and 1.5  $\mu$ s RC filters (24 Vdc compatible). IN21 & IN22 have fixed pull-ups to +5V and the same electrical specs as IN1 & IN11 otherwise. IN2~IN5 and IN12~IN15 are programmable as single ended or differential inputs. IN6~9 and IN16~19 are single ended opto-isolated inputs with a common terminal for each group that can connect to ground or +24 Vdc to work with current-sourcing or current-sinking outputs from a control system. IN10 & IN20 are for motor overtemp switches and have fixed pull-ups to +5 Vdc and 330  $\mu$ s RC filters to Schmitt triggers. These are found on the feedback connectors for Axis-A (IN10) and Axis-B (IN20). The 800-1819 does not utilize IN21 and IN22 and dedicates IN16-19 to the output of optical limit switches mounted on motors.

For a list of input functions, see the *CME 2 User Guide*.

#### Input Filters

Two types of input RC filters are used: GP (general-purpose) and HS (high-speed). Input reference functions such as Pulse and Direction, Pulse Up/Pulse Down, and Quadrature A/B are wired to inputs that have the HS filters, and inputs with the GP filters are used for general-purpose logic functions, limit switches, and the motor temperature sensor.

#### Debounce Time

To prevent undesired multiple triggering caused by switch bounce upon switch closures, each input can be programmed with a debounce time. The programmed time specifies how long an input must remain stable at a new state before the drive recognizes the state. The debounce time is ignored if the input is used as a digital command input.

#### Configure for Pull Up/Pull Down Resistors by Groups

Pre-defined groups of inputs can be programmed to have either an internal pull up or pull down resistor.

### 2.9.2: Limit Switches

#### Use Digital Inputs to Connect Limit Switches

Limit switches help protect the motion system from unintended travel to the mechanical limits. In the Xenus Plus Single Axis products, any of the digital inputs 1-14 (1-20 for Xenus Plus Dual Axis), can be programmed as positive or negative limit switch inputs. With the drive operating as a CAN node, an input can also be programmed as a home limit switch for CANopen homing operations.

#### Diagram: Sample Placement of Limit Switches

The following diagram shows these limit switches in use on a sample motion stage.

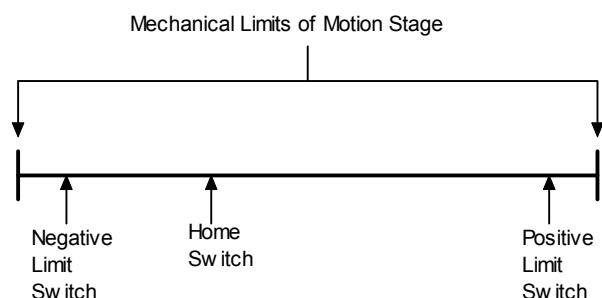



**How the Drive Responds to Limit Switch Activation**

The drive stops any motion in the direction of an active limit switch, as described below. The response is identical in current and velocity modes, and slightly different in position mode.

Mode	Drive Response to Active Positive (or Negative) Limit Switch
Current	Drive prohibits travel in positive (or negative) direction. Travel in the opposite direction is still allowed.
Velocity	Drive status indicator flashes green at fast rate. Warning is displayed on CME 2 Control Panel and CME 2 Control Panel limit indicator turns red.
Position	Drive stops responding to position commands until the drive is disabled and re-enabled, or the fault is cleared over the CANopen interface. Drive status indicator flashes green at fast rate. Warning is displayed on CME 2 Control Panel and CME 2 Control Panel limit indicator turns red. Default behavior: If, after re-enabling the amp, the limit switch is still active, the drive will only allow movement in the opposite direction. "Hold position" behavior: If the *Hold position when limit switch is active option is set, the drive prevents any motion while a limit switch is active. CAUTION: If the drive is switched back to current or velocity mode with this option selected, the limit switches will no longer function. For more information on *Hold position when limit switch is active, see the <i>CME 2 User Guide</i> .

**Using Custom Output to Signal Limit Switch Activation**

In addition to the response described above, any of the drive’s digital outputs can be configured to go active when a positive or negative limit switch is activated.

For more information, see the *CME 2 User Guide*.

**2.9.3: Analog Inputs**

Two programmable differential analog inputs, AIN1 and AIN2 are connected on J12. As reference inputs they can take position/velocity/torque commands from a controller. If not used as command inputs, they can be used as general-purpose analog inputs. The input voltage range is ±10V.

## 2.10: Outputs, XEL/XPL/XML

The Xenus Plus XEL, XPL and XML drives have 6 programmable digital outputs (one opto-isolated and five non-isolated) and one programmable analog output.

The XEL/XPL/XML features six programmable digital outputs. OUT1~5 are general-purpose outputs. OUT6 is specifically designed as a brake output but can be programmed for other functions. For a list of digital output functions, see [Control I/O \(p. 107\)](#)

OUT1~OUT3 are connected on J8. Opto-isolated OUT4 and OUT5 are on J9. OUT6 (Brake) is on J4.

OUT1 and OUT2 are current sinking MOSFETs, each with a pull-up resistor, in series with a diode, connected to the drive's internal +5 Vdc supply. This design allows the outputs to be directly connected to optically isolated PLC inputs that reference a voltage higher than +5 Vdc, typically +24 Vdc. The diode prevents current flow between the +24 Vdc supply and the internal +5 Vdc supply through the pull-up resistor. This current, if allowed to flow, could turn on the PLC input, giving a false indication of the drive's true output state. OUT1 and OUT2 require an external fly-back diode to be installed across any inductive loads, such as relays, that are connected to them.

OUT3 is a 5V high speed buffered CMOS output.

OUT4 and OUT5 are opto-isolated Darlingtontons with a 30 Vdc maximum output. Zener clamping diodes across outputs allow driving of resistive-inductive (R-L) loads without external flyback diodes. The outputs are two-terminal and for connection to +24V or ground to source or sink current. The output current rating is 20 mA.

The brake output (OUT6) is described below in Brake Operation.

There is one programmable analog output (AOUT1). It has an output voltage range of  $\pm 5$  Vdc. An op-amp buffers the output of a 12-bit D/A converter.

## 2.11: Outputs, XE2/XP2/XM2/800-1818/800-1819

XE2/XP2/XM2/800-1818 models have 7 programmable digital outputs, while the 800-1819 has 5. OUT1~OUT5 are opto-isolated, two-terminal SSR (Solid State Relay) switches, each with a series resistor and Zener clamping diodes across the outputs allow driving of resistive-inductive (R-L) loads without the need for external flyback diodes.

The 800-1819 does not utilize OUT 4~5. For a list of digital output functions, see the *CME 2 User Guide*. Brake outputs (OUT6 and OUT7), are isolated, open-drain MOSFETs with internal flyback diodes connected to the +24 Vdc input. OUT6 and OUT7 are specifically designed as brake outputs for axis A and B respectively, but can be programmed to perform other functions.

There are no analog outputs in XE2/XP2/XM2/800-1818/800-1819.

## 2.12: Brake Operation

### Digital Output Controls Brake

Many control systems employ a brake to hold the axis when the drive is disabled. Xenus Plus drives have digital outputs designed specifically for brake outputs. Other outputs can be used but these are recommended. Unlike the other outputs, these brake specific outputs are optically isolated from the control signals and have internal fly back diodes connected to the +24 Vdc input. By eliminating the need to connect into the drive control connector, having the brake output on the +24 Vdc power connector simplifies wiring when the brake wires are in the power cable of the motor.

\* There should be only one conductor in each position of the brake connector. If brakes are to be wired directly to J4 or J5 for their 24V power, use a double wire ferrule. Information for ferrules can be found in §4.12.

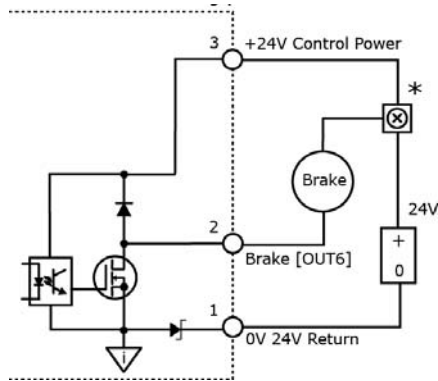

XEL, XPL, XML

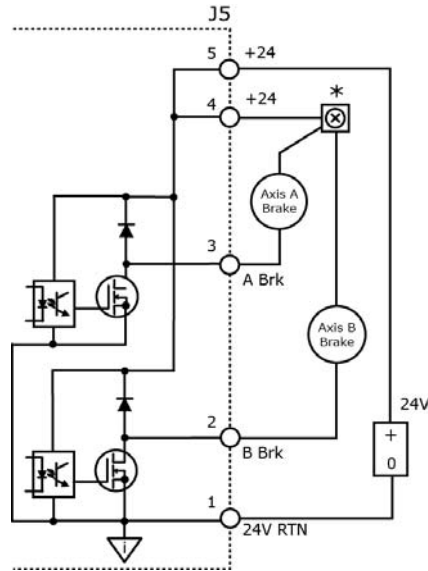

XE2, XP2, XM2

For more information, see [Logic Supply / Brake \(p. 96\)](#).

**Brake/Stop Sequences**

- Disabling the drive by a hardware or software command starts the following sequence of events.
- The motor begins to decelerate (at Abort Deceleration rate in position mode or Fast Stop Ramp rate in velocity mode). At the same time, the Brake/Stop Delay Time count begins. This allows the drive to slow the motor before applying the brake.
- When the motor slows to Brake/Stop Activation Velocity OR the Brake/Stop Delay Time expires, the brake output activates and PWM Delay Brake/Stop Response Time count begins.
- When response time has passed, the drive’s output stages are disabled. This delay ensures the brake has time to lock in before disabling the power section

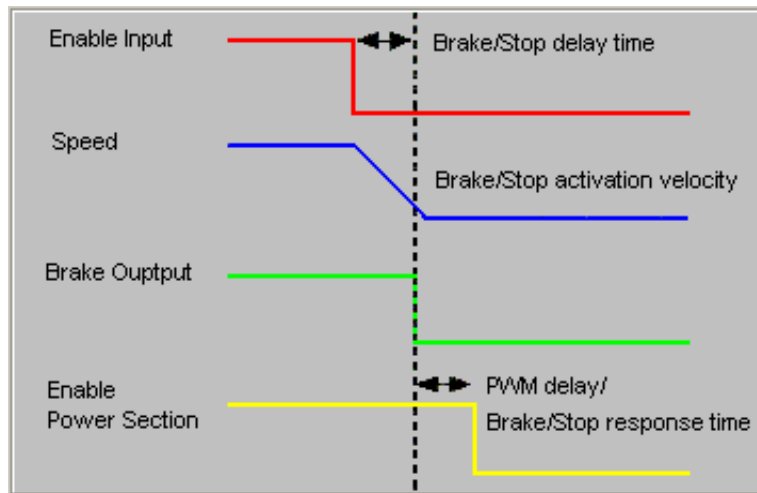

This sequence is not available in the current mode of operation. Instead, in current mode, the drive output turns off and the brake output activates immediately when the disable command is received.

### Motor Wiring Detection

When a brake is in use, the drive can check for a disconnected motor. Upon enable, the drive will apply current to the motor output while keeping the brake engaged for the Brake Hold Time on Enable. If no current can be detected in the windings, the brake will not be released and a Wiring Detection Fault will occur. If the motor is connected and current can be detected, the brake will be released after the programmable time expires.

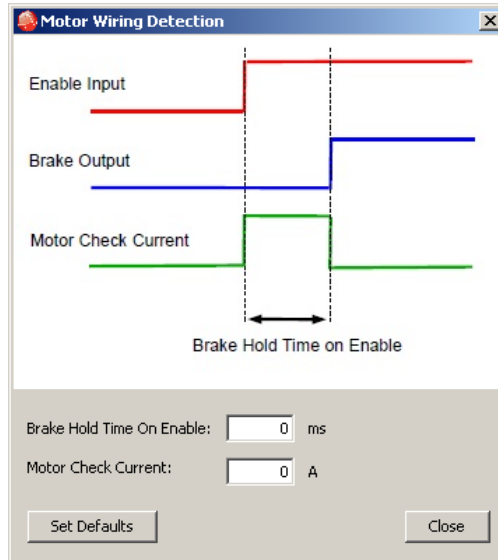

### Motor Brake Enable Delay Time

The programmable value in the Motor Wiring Detection also sets the time between the activation of the brake and PWM outputs of the drive.

- When the value is positive, the PWM outputs will turn on when the drive is enabled and the brake will be released after the programmable delay expires.
- When the value is negative, the brake is released immediately when the drive is enabled and the PWM outputs are enabled after the programmable delay expires.

The graphic below is not part of CME2, but shows the timings in the same colors as the Brake setting screen.

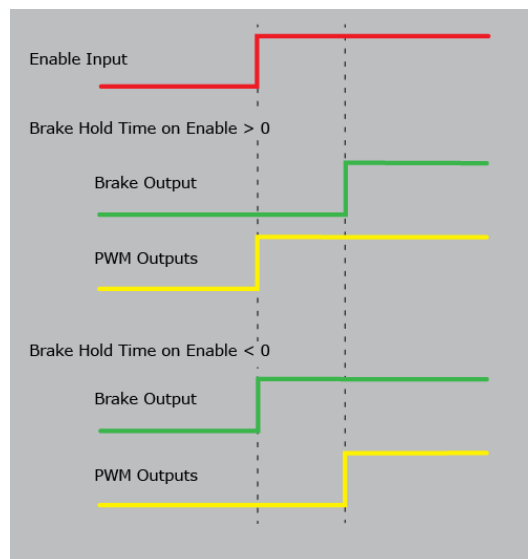

## 2.13: Regen Resistor Theory

### 2.13.1: XEL/XPL/XML

#### Regeneration

When a load is accelerated, electrical energy is converted into mechanical energy. During deceleration the conversion is reversed. This is called regeneration. Some of this regenerated energy is lost to friction in the mechanical system. More of this energy is converted to heat due to I<sup>2</sup>R losses in the motor windings, cabling, and drive electronics. The remainder of the energy is added to the electrical energy already stored in the internal capacitor bank of the drive. The result of this energy being added is an increase in the voltage on the capacitor bank.

#### External Regen Resistor

If too much energy is added to the capacitor bank, the voltage rises to a point where the drives over voltage protection shuts down the drive. To prevent this, an internal transistor switch can drive an external regen resistor to dissipate the regen energy so that the internal bus voltage is limited to a value that permits the continued operation of the drive PWM outputs.

#### Regen Circuit Components

The drive provides an internal transistor that is used in combination with an external resistor. Copley Controls supplies compatible resistors as described in [Regen Resistor Assemblies \(p. 162\)](#). When using a resistor acquired from another source, be sure it meets the specifications described in [Regen Resistor Sizing and Specification \(p. 132\)](#).

#### Regen Circuit Protections

The drive protects the regen circuit against short circuit, and uses I<sup>2</sup>T peak current/time algorithms to protect both the external resistor and the internal transistor.

#### Configurable Custom Resistor

The following values can be entered for a custom resistor using CME 2:

Option	Description
Resistance Value	Value in Ohms of the resistor
Continuous Power	Continuous power rating of the resistor
Peak Power	Peak power rating of the resistor
Time at Peak Power	Time at peak power of resistor

For more information, see [Regen Resistor Sizing and Specification \(p. 132\)](#).

2.13.2: XE2/XP2/XM2/800-1819

Regeneration

The Xenus Plus Dual Axis drives, excluding the 800-1818, have an internal regen resistor which can dissipate regenerative energy that exceeds the absorption capacity of the internal bus capacitance. The internal regen resistor will be switched on when the energy shown in the table has been absorbed and the bus voltage driven up to 390 Vdc at which point the internal regen resistor will be switched to dissipate the kinetic energy of the load.

Absorption	
Vac	E
100	155
120	145
200	85
240	43

Absorption is the energy that can be transferred to the internal capacitors during deceleration. This table shows the energy absorption in W·s for a drive operating at some typical mains voltages. The capacitor bank is 2350 uF and the energy absorption is shared with both axes. If the deceleration energy is less than the absorption capacity of the drive, then a regeneration resistor will not be used because the bus voltage will not rise enough to hit the over-voltage level that would disable the PWM outputs.

E Energy Joules, Watt·seconds  
 J Rotary Moment of Inertia kg·m<sup>2</sup>  
 P Power Watts

Step 1: Find the energy of motion for a rotating load, for this example let it be 75 Joules:

$$E = J * RPM^2 / 182 = 75 J$$

Step 2: Subtract the absorption at your mains voltage to get the energy that must be dissipated in the regen resistor during the Regen Time.

Use 240 Vac:

$$75J - 43J = 32 J$$

Step 3: Divide the regen energy by the continuous power rating of 20 Watts to get the dwell time that can dissipate the regen energy in the resistor:

$$\text{Dwell Time} = 32 \text{ Joules} / 20 \text{ Watts} = 1.6 \text{ sec}$$

Step 4: Find the total regen cycle time by adding the deceleration time to the dwell time:

$$\begin{aligned} \text{Regen Time} &= 1.25 \text{ sec} \\ \text{Dwell Time} &= 1.60 \text{ sec} \\ \text{Cycle Time} &= 2.85 \text{ sec} \end{aligned}$$

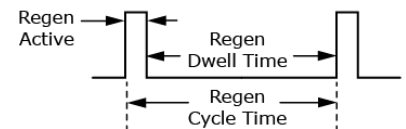
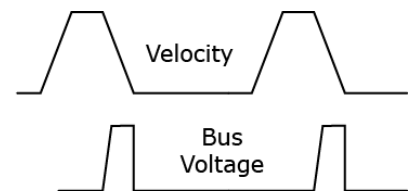
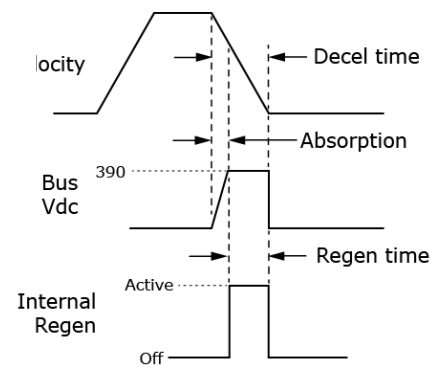

Internal Regen Resistor Ratings	
Max Energy	100 W·s (J)
Resistance	18 W
Power, continuous	20 W
Power, peak	70 W
Time	2000 ms

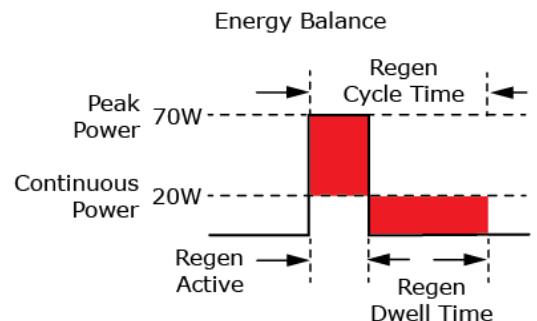

### Internal Regen Resistor

If too much energy is added to the capacitor bank, the voltage rises to a point where the drive's over voltage protection shuts down the drive. To prevent this, a regen circuit shunts some of the energy into the internal regen resistor when the voltage rises too high.

### External Regen Resistor

All of the Xenus Plus Dual Axis drives, including the 800-1818, provide for connection to an external regen resistor. In the case of the XE2/XP2/XM2/800-1819 models, for regen energy that exceeds the rating of the internal regen resistor, an external regen resistor can be used. This is done by unplugging the internal regen resistor from J2, and connecting the external regen resistor in its place. Model 800-1818 drives do not have an internal regen resistor but are supplied with a regen mating plug connected to J2. This mating plug is used to connect to an external regen resistor. For electrical safety reasons and for all Xenus Plus Dual models, the specified mating plug must always be plugged into and secured to J2 regardless of whether a regen resistor, internal or external, is connected.

### Regen Circuit Components

The drive provides an internal transistor that is used in combination with an external resistor. Copley Controls supplies compatible resistors as described in [Regen Resistor Assemblies \(p. 162\)](#). When using a resistor acquired from another source, be sure it meets the specifications described in [Regen Resistor Sizing and Specification \(p. 132\)](#).

### Regen Circuit Protections

The drive protects the regen circuit against short circuit, and uses I<sup>2</sup>T peak current/time algorithms to protect both the external resistor and the internal transistor.

### Configurable Custom Resistor

The following values can be entered for a custom resistor using CME 2:

Option	Description
Resistance Value	Value in Ohms of the resistor
Continuous Power	Continuous power rating of the resistor
Peak Power	Peak power rating of the resistor
Time at Peak Power	Time at peak power of resistor

# CHAPTER

## 3: SPECIFICATIONS

This chapter describes the drive specifications. Contents include:

- 3.1: Agency Approvals ..... 65
- 3.2: Power Input ..... 65
- 3.3: Power Output ..... 66
- 3.4: Control Loops ..... 67
- 3.5: Regen Circuit Output (External Regen Resistor) ..... 67
- 3.6: Regen Circuit Output (Internal Regen Resistor) ..... 67
- 3.7: Digital Command Inputs ..... 68
- 3.8: Analog Inputs ..... 68
- 3.9: Digital Inputs ..... 69
- 3.10: Analog Outputs ..... 70
- 3.11: Digital Outputs ..... 70
- 3.12: Encoder Power Outputs ..... 71
- 3.13: Primary Encoder Inputs ..... 71
- 3.14: Analog Encoder Inputs ..... 72
- 3.15: Hall Switch Inputs ..... 73
- 3.16: Resolver Interface ..... 74
- 3.17: Multi-Mode Port ..... 75
- 3.18: Serial Interface ..... 76
- 3.19: Network Interfaces ..... 77
- 3.20: Status Indicators ..... 78
- 3.21: Fault Levels ..... 78
- 3.22: Power Dissipation ..... 79
- 3.23: Thermal Impedance ..... 79
- 3.24: Mechanical and Environmental ..... 80
- 3.25: Dimensions ..... 81



### 3.1: Agency Approvals

- CE Compliant
- UL Compliant
- RoHS Compliant

Standard	XEL/XPL/XML	XE2/XP2/XM2/800-1818/800-1819
UL	UL 61010-1 Compliant	UL 61800-5-1 Compliant
Functional Safety		IEC 61508-1, IEC 61508-2 ISO 13849-1 ISO 13849-2 IEC 61800-5-2
Electrical safety	IEC 61010-1 UL 61010-1	IEC 61800-5-1 UL 61800-5-1
EMC	IEC 55011:2009 /A1:2010, CL A IEC 61000-6-1:2007 SEMI F47-0706	IEC 61800-3:2004+A1:2011* SEMI F47-0706
* The Xenus Plus Dual Axis models comply with the requirements for immunity to low frequency disturbances specified in IEC 61800-3:2004+A1:2011		

\*CE Declaration of Conformity available at <http://www.copleycontrols.com/Motion/Downloads/xenusData.html>

### 3.2: Power Input

Model	XEL-230-18 (-R) XPL-230-18 (-R) XML-230-18 (-R)	XEL-230-36,40 (-R) XPL-230-36,40 (-R) XML-230-36,40 (-R)	XEL-230-40 (-R) XPL-230-40 (-R) XML-230-40 (-R) 800-1819	800-1818
Mains Voltage	100 - 240 Vac 1 Ø or 3 Ø			
Mains Frequency	47 to 63 Hz			
Max Mains Current, 1Ø*	10.1 Arms	20.0 Arms	18.0 Arms	16.0 Arms
Max Mains Current, 3Ø*	6.4 Arms	10.4 Arms	14.0 Arms	7.5 Arms
Current Inrush	15 A peak at 120 Vac 35 A peak at 240 Vac			
Mains Supply Short Circuit Current Rating (SCCR)	5 kArms maximum			
Logic Supply Voltage	+20 to +32 Vdc			
Logic Supply Current	500 mA maximum		1.1 A maximum**	
*The actual mains current is dependent on the mains voltage, number of phases, and motor load and operating conditions. The Maximum Mains Currents shown above occur when the drive is operating from the maximum input voltage and is producing the rated continuous output current at the maximum output voltage. **Logic supply current draw depends on the number of encoders connected to the drive. The maximum current draw given assumes that the four drive encoder supplies (+5V) are each loaded to 500mA.				

### 3.3: Power Output

Model	XEL-230-18 (-R) XPL-230-18 (-R) XML-230-18 (-R)	XEL-230-36 (-R) XPL-230-36 (-R) XML-230-36 (-R)	XEL-230-40 (-R) XPL-230-40 (-R) XML-230-40 (-R)	XE2-230-20 (-R) XP2-230-20 (-R) XM2-230-20 (-R) 800-1819	800-1818
Peak Current	18 Adc [12.7 Arms]	36 Adc [25.5 Arms]	40 Adc [28.3 Arms]	20 Adc [14 Arms]	9 Adc [6.36 Arms]
Peak Current Time	1 Second				
Continuous Current*	6 Adc [4.24 Arms]	12 Adc [8.5 Arms]	20 Adc [14.1 Arms]	10 Adc [7 Arms]	4.5 Adc [3.18 Arms]
Efficiency	>97% @ 230 Vac and rated continuous current				
Output Type	3-phase IGBT inverter 16 kHz center-weighted PWM space-vector modulation				
PWM Ripple Frequency	32 kHz				
Minimum Load Inductance	400 uH line-to-line** NOTE: See <a href="#">Xenus Plus Filter (p.146 Error! Bookmark not defined.)</a> .				
Capacitor Discharge	Wait 5 minutes after disconnecting mains power before handling				
* Heat sinking and/or forced air cooling required for continuous output power rating					
** Consult factory for operation with inductance lower than 400 uH					

### 3.4: Control Loops

Type: Current Velocity Position	100% digital.
Sampling rate (time): Current Velocity Position	16 kHz (62.5 $\mu$ s) 4 kHz (250 $\mu$ s) 4 kHz (250 $\mu$ s)
Current Loop Small Signal Bandwidth	> 2 kHz (Tuning and load impedance dependent)
Loop Filters	Programmable Velocity loop output filter default: 200 Hz low pass.
Bus Voltage Compensation	Changes in bus or mains voltage do not affect tuning.

### 3.5: Regen Circuit Output (External Regen Resistor)

Model	XEL-230-18 (-R) XPL-230-18 (-R) XML-230-18 (-R)	XEL-230-36,40 (-R) XPL-230-36,40 (-R) XML-230-36,40 (-R)	XE2-230-20 (-R) XP2-230-20 (-R) XM2-230-20 (-R) 800-1819	800-1818
Continuous Power	2 kW	4 kW	4 kW	4 kW
Peak Power	5 kW	10 kW	10 kW	10 kW
Minimum Resistance	30 $\Omega$	15 $\Omega$	15 $\Omega$	15 $\Omega$
Minimum Resistor Wattage	25 W	50 W	50 W	50 W
Turn On Voltage	+390 Vdc			
Turn Off Voltage	+380 Vdc			
DC Bus Capacitance	2350 $\mu$ F nominal			
Regen Energy Absorption Capacity				
Input Voltage 120 Vac	145 Joules			
208 Vac	77 Joules			
240 Vac	43 Joules			

### 3.6: Regen Circuit Output (Internal Regen Resistor)

#### XE2, XP2, XM2, 800-1819

Internal Regen Resistor Ratings	
Max Energy	100 W·s (J)
Resistance	18 $\Omega$
Power, continuous	20 W
Power, peak	70 W
Time	2000 mS

### 3.7: Digital Command Inputs

Digital Position Command	Pulse and direction, Count up/ count down maximum rate	2 MHz (with active driver)
	Quadrature A/B encoder maximum rate	2 M line/sec (8 M count/sec after quadrature)
Digital Current & Velocity Command	PWM frequency range	1 kHz - 100 kHz
	PWM minimum pulse width	220 ns

### 3.8: Analog Inputs

#### XEL/XPL/XML

Channels	3 (AIN1~IN3)	
	AIN1~AIN2	AIN3
Type	Differential, non-isolated	Single-ended
Measurement Range	±10 Vdc	0-5 Vdc
Maximum Voltage Differential	±10 Vdc	±10 Vdc
Input to Ground	±10 Vdc	±10 Vdc
Input Impedance	5 kΩ	4.99 kΩ pull-up to 5V
Resolution	16 Bit	12 Bit
Anti-aliasing filter	14.5 kHz	27 Hz
Scan Time	62.5 μs	250 μs
Function	Programmable. Current, velocity, or position command	Motor temperature sensor

#### XE2/XP2/XM2/800-1818/800-1819

Channels	2
	AIN1~AIN2
Type	Differential, non-isolated
Measurement Range	±10 Vdc
Maximum Voltage Differential	±10 Vdc
Input to Ground	±10 Vdc
Input Impedance	5 kΩ
Resolution	14 bit
Anti-aliasing filter	14.5 kHz
Scan Time	62.5 μs
Function	Programmable

### 3.9: Digital Inputs

#### XEL/XPL/XML

Channels	15 (IN1~IN15)		
	IN1~IN2, IN15	IN3~IN6	IN7~IN14
Type	Schmitt trigger w/ RC filter, 24Vdc max	Non-isolated line receiver w/ RC filter, programmable as 4 single-ended or 2 differential Single-ended	Opto-isolated, bi-polar, 2 groups of 4 with common for each group
Input Voltage Range	0 Vdc-24 Vdc	0-12Vdc	±15 - 30 Vdc
Logic Low Input Voltage	<= +1.13 Vdc	<= +2.3 Vdc	N/A
Logic High Input Voltage	>= +3.15 Vdc	>= +2.7 Vdc	N/A
Scan Time	250 μs	250 μs	250 μs
Debounce Type	Digital	Digital	Digital
Time	Programmable 0 - 10,000 ms	Programmable 0 - 10,000 ms	Programmable 0 - 10,000 ms
Function	IN1 enable IN2~IN15 programmable Note: Inputs 3&4 and 5&6 can be programmed to function as differential pairs as digital command inputs.		

#### XE2/XP2/XM2/800-1818/800-1819

Channels	XE2/XP2/XM2/800-1818: 22 (IN1~IN22), 800-1819: 20 (IN1~IN20)			
	IN1,11,21~22	IN2~5,12-15	IN6~9,16~19	IN10,20
Type	Schmitt trigger w/ RC filter, 24Vdc max	Non-isolated line receiver w/ RC filter, programmable as 4 single-ended or 2 differential Single-ended	Opto-isolated, bi-polar, 2 groups of 4 with common for each group	Motor overtemp signals on feedback connectors
Input Voltage Range	0 Vdc-24 Vdc	0-12Vdc	±15 - 30 Vdc	0 Vdc-24 Vdc
Logic Low Input Voltage	<= +1.13 Vdc	<= +2.3 Vdc	<= +6 Vdc	<= +1.13 Vdc
Logic High Input Voltage	>= +3.15 Vdc	>= +2.7 Vdc	>= +10 Vdc	>= +3.15 Vdc
Scan Time	250 μs			
Debounce Type	Digital	Digital	Digital	Digital
Time	Programmable 0 - 10,000 ms	Programmable 0 - 10,000 ms	Programmable 0 - 10,000 ms	Programmable 0 - 10,000 ms
Function	All programmable Note: 800-1819 does not utilize IN21-22 and dedicates IN16-19 to optical limit switches of motors.			

### 3.10: Analog Outputs

**XEL/XPL/XML**

Channels	1
Type	Single-ended
Range	0-5 Vdc
Resolution	12 Bit

NOTE: There are no analog outputs available on XE2/XP2/XM2/800-1818/800-1819 drives.

### 3.11: Digital Outputs

**XEL/XPL/XML**

Channels	6 (OUT1~OUT6)			
	OUT1~OUT 2	OUT3	OUT4~OUT5	OUT6
Type	Current-sinking, open drain MOSFET with External flyback diode required if driving inductive loads	High-speed 5Vdc CMOS buffer	Opto-isolated Darlingtons with 36V Zener diodes across outputs	Opto-isolated motor brake control, current-sinking with flyback diode to +24V
Maximum Voltage	+40 Vdc	5Vdc	30Vdc	+32 Vdc
Maximum Sink Current	1 Adc	+/- 32 mA	20 mA	1 Adc
Low Level Output Resistance	<0.2 Ω	Not applicable (Rout only applies to MOSFET outputs)	Not applicable (Rout only applies to MOSFET outputs)	0.14 Ω
Function	Programmable			Brake/Programmable

**XE2/XP2/XM2/800-1818/800-1819**

Channels	XE2/XP2/XM2/800-1818: 7 (OUT1~OUT7), 800-1819: 5 (OUT1~OUT3, OUT6~OUT7)	
	OUT1~OUT 5	OUT 6~OUT 7
Type	Opto-isolated MOSFET SSR with 1Ω series resistor and 36V Zener flyback diodes across outputs	Opto-isolated, current-sinking with flyback diode to +24 Vdc
Maximum Voltage	30Vdc	+32 Vdc
Maximum Sink Current	300 mA	1 Adc
Low Level Output Resistance	Not applicable	0.14 Ω
Function	Programmable Note: 800-1819 does not utilize OUT4~5	Brake/Programmable

### 3.12: Encoder Power Outputs

**XEL/XPL/XML**

Number	2
Voltage Output	+5 Vdc ±2%
Maximum Current Output	400 mA
Short Circuit Protection	Fold-back current limiting
Function	Provides power for motor encoder and/or Hall switches.

**XE2/XP2/XM2/800-1818/800-1819**

Number	4
Voltage Output	+5 Vdc ±2%
Maximum Current Output	500 mA
Short Circuit Protection	Fold-back current limiting
Function	Provides power for motor encoders and/or Hall switches.

### 3.13: Primary Encoder Inputs

**XEL/XPL/XML**

Channels	3
Type	Differential RS-422 line receiver w/ RC filter Non-isolated
Signals	A, /A, B, /B, S, /S, X*, /X*
Input Voltage Range	±7 Vdc
Differential Input Threshold	±0.2 Vdc
Termination Resistance	121 Ω
Maximum Frequency	5 MHz Line (20 Mcount/sec)
Function	Incremental or analog encoder or resolver required for sinusoidal commutation and position or velocity modes of operation.
* X is equivalent to Marker, Index, or Z channels, depending on the encoder manufacturer. This channel is only required in certain homing modes while under CAN control.	

**XE2/XP2/XM2/800-1818**

Channels	8
Type	Differential RS-422 line receiver w/ RC filter Non-isolated
Signals	A, /A, B, /B, S*, /S*, X*, /X* for each axis
Input Voltage Range	±7 Vdc
Differential Input Threshold	±0.2 Vdc
Termination Resistance	A and B Channels: 121 Ω X Channel: 130 Ω with 1 kΩ pull-up to 5V on X and 1 kΩ pull-down on /X S Channel: 221 Ω with 1 kΩ pull-up to 5V on S and 1 kΩ pull-down on /S
Maximum Frequency	5 MHz Line (20 Mcount/sec)
Function	Incremental or analog encoder or resolver required for sinusoidal commutation and position or velocity modes of operation.
* S and X channels are bi-directional.	

NOTE: There is no Digital Encoder feedback on 800-1819 drives.

## 3.14: Analog Encoder Inputs

### XEL/XPL/XML

Channels	2
Type	Differential, non-isolated
Signals	Sin(+), Sin(-), Cos(+), Cos(-)
Nominal Voltage	1 Vpk-pk
Maximum Voltage	
Differential	±0.6 Vdc
Input to Ground	0 to +3.5 Vdc
Differential Input Impedance	121 Ω
Bandwidth	230 kHz
Interpolation	1 to 1024, programmable
Function	Incremental or analog encoder or resolver required for sinusoidal commutation and position or velocity modes of operation.

### XE2/XP2/XM2/800-1818

Channels	4
Type	Differential, non-isolated
Signals	Sin(+), Sin(-), Cos(+), Cos(-) for each axis.
Nominal Voltage	1 Vpk-pk
Maximum Voltage	
Differential	±0.6 Vdc
Input to Ground	0 to +3.5 Vdc
Differential Input Impedance	121 Ω
Bandwidth	230 kHz
Interpolation	1 to 1024, programmable
Function	Incremental or analog encoder or resolver required for sinusoidal commutation and position or velocity modes of operation.

NOTE: There is no Analog Encoder feedback on 800-1819 drives.



## 3.15: Hall Switch Inputs

### XEL/XPL/XML

Channels	3 (U, V and W)
Type	74HC14 Schmitt trigger w/ RC Filter 10 k $\Omega$ pull up resistor to internal +5 Vdc
Input Voltage Range	0 Vdc - +24 Vdc
Low Level Input Voltage	< +1.35 Vdc
High Level Input Voltage	> +3.65 Vdc
Timing	Edge detection.
RC Filter Time Constant	1 $\mu$ s when driven by active sources.
Function	Commutation of brushless motors in trapezoidal mode. Commutation initialization and phase error detection in sinusoidal mode.

### XE2/XP2/XM2/800-1818

Channels	6 (U, V and W for each axis)
Type	74HC14 Schmitt trigger w/ RC Filter 10 k $\Omega$ pull up resistor to internal +5 Vdc
Input Voltage Range	0 Vdc - +24 Vdc
Low Level Input Voltage	< +1.35 Vdc
High Level Input Voltage	> +3.65 Vdc
Timing	Edge detection.
RC Filter Time Constant	1 $\mu$ s when driven by active sources.
Function	Commutation of brushless motors in trapezoidal mode. Commutation initialization and phase error detection in sinusoidal mode.

NOTE: Digital Halls not supported 800-1819 drives.

### 3.16: Resolver Interface

**XEL/XPL/XML**

Channels	3
Type	Transmit, 1:1 to 2:1 transformation ratio
Signals	Ref(+), Ref(-), Sin(+), Sin(-), Cos(+), Cos(-)
Resolution	14 bits (equivalent to a 4096 line quadrature encoder)
Reference Frequency	8 kHz
Reference Voltage	2.8 Vrms, auto-adjustable by drive for proper feedback levels.
Reference Max Current	100 mA
Max RPM	20,000
Function	Incremental or analog encoder or resolver required for sinusoidal commutation and position or velocity modes of operation.

**XE2/XP2/XM2**

Channels	6
Type	Transmit, 1:1 to 2:1 transformation ratio
Signals	Ref(+), Ref(-), Sin(+), Sin(-), Cos(+), Cos(-) for each axis
Resolution	14 bits (equivalent to a 4096 line quadrature encoder)
Reference Frequency	8 kHz
Reference Voltage	2.8 Vrms, auto-adjustable by drive for proper feedback levels.
Reference Max Current	100 mA per axis
Max RPM	20,000
Function	Incremental or analog encoder or resolver required for sinusoidal commutation and position or velocity modes of operation.

**800-1819**

Contact Copley Controls for details.

### 3.17: Multi-Mode Port

#### XEL/XPL/XML

Channels	4
Type	Bi-Directional, Differential RS-422. Non-isolated
Signals	A, /A, B, /B, X, /X, S, /S
Input Voltage Range	±7 Vdc
Differential Input Threshold	±0.2 Vdc
Termination Resistance	None
Function Programmable	<p>Output Mode</p> <ul style="list-style-type: none"> <li>Buffered primary incremental encoder</li> <li>Emulated incremental or serial encoder from analog encoder or resolver</li> </ul> <p>Input Mode</p> <ul style="list-style-type: none"> <li>Secondary digital quadrature input</li> <li>Current / Velocity mode, PWM input</li> <li>Position Mode, Digital command input</li> </ul>
Maximum Frequency	
Output Mode	
Buffered Encoder	5 MHz Line (20 Mcount/sec)
Emulated Encoder	4.5 MHz Line (18 Mcount/sec)
Input Mode	
PWM Input	100Khz
Digital Command	5 MHz (50% Duty Cycle)
Secondary Encoder	5 MHz Line (20 Mcount/sec)

#### XE2/XP2/XM2/800-1818/800-1819

Channels	8
Type	Bi-Directional, Differential RS-422. Non-isolated
Signals	A, /A, B, /B, X, /X, S, /S for each axis
Input Voltage Range	±7 Vdc
Differential Input Threshold	±0.2 Vdc
Termination Resistance	A and B Channels: None X Channel: 130 Ω with 1 kΩ pull-up to 5V on X and 1 kΩ pull-down on /X S Channel: 221 Ω with 1 kΩ pull-up to 5V on S and 1 kΩ pull-down on /S
Function Programmable	<p>Output Mode</p> <ul style="list-style-type: none"> <li>Buffered primary incremental encoder</li> <li>Emulated incremental or serial encoder from analog encoder or resolver</li> </ul> <p>Input Mode</p> <ul style="list-style-type: none"> <li>Secondary digital quadrature input</li> <li>Current / Velocity mode, PWM input</li> <li>Position Mode, Digital command input</li> </ul>
Maximum Frequency	
Output Mode	
Buffered Encoder	5 MHz Line (20 Mcount/sec)
Emulated Encoder	4.5 MHz Line (18 Mcount/sec)
Input Mode	
PWM Input	100Khz
Digital Command	5 MHz (50% Duty Cycle)
Secondary Encoder	5 MHz Line (20 Mcount/sec)

### 3.18: Serial Interface

**XEL/XPL/XML**

Channels	1
Type	RS-232, DTE
Signals	Rxd, Txd, Gnd
Baud Rate	9,600 to 115,200 (defaults to 9600 on power up or reset)
Data Format	N, 8, 1
Flow Control	None
Protocol	Binary or ASCII format
Function	Set up, control and diagnostics status

**XE2/XP2/XM2/800-1818/800-1819**

Channels	1
Type	RS-232, DTE
Signals	Rxd, Txd, Gnd
Baud Rate	9,600 to 115,200 (defaults to 9600 on power up or reset)
Data Format	N, 8, 1
Flow Control	None
Protocol	Binary or ASCII format
Function	Set up, control and diagnostics status

### 3.19: Network Interfaces

<b>Model</b>	<b>XEL/XE2 800-1818/800-1819</b>	<b>XPL/XP2</b>	<b>XML/XM2</b>
Channels	1	1	1
Connectors	2 eight-position (RJ-45 style).	2 eight-position (RJ-45 style).	2 Duplex type SC optical fiber connector.
Signals	100BASE-TX	CAN_H, CAN_L, CAN_Gnd (CAN +5 Vdc Pass through only)	MACRO (Motion And Control Ring Optical).
Format	EtherCAT	CAN V2.0b physical layer for high-speed connections compliant	
Protocol	CANopen over EtherCAT (CoE) based on DSP-402 for motion control devices.	Motion Control Device Under DSP-402 of the CANopen DS-301 V4.01 (EN 50325-4) Application Layer	MACRO
Supported Modes	Cyclic Synchronous Position & Velocity.	Profile Current, Velocity, and Position, PVT (Position-Velocity-Time), and Homing.	Torque (current), Velocity.
Node Address Selection	Slaves are automatically assigned addresses based on their position in the bus. Two 16-position hexadecimal rotary switches can be used to define a cabling-independent Station Alias.	Two 16-position hexadecimal rotary switches on front panel OR programmable digital inputs OR stored in flash memory OR combination of above.	Two 16-position hexadecimal rotary switches are used to define a MACRO node address.
Bus Termination	No termination required.	External 121 Ω resistor across CAN_H and CAN_L when termination plug is installed in second connector.	No termination required.
Function	Real-time motion control	Real-time motion control	Real-time motion control

### 3.20: Status Indicators

Model	XEL	XPL	XML
<b>LED:</b> Network Status	<b>STAT</b> Bicolor LED, status of EtherCAT bus indicated by color and blink codes to CAN Indicator Specification 303-3 Ethernet: Link (green) shows port open-closed ACT (yellow) shows activity	<b>NET</b> Bicolor LED, status of CAN bus indicated by color and blink codes to CAN Indicator Specification CiA 303-3	<b>NET</b> Bicolor LED, status of the MACRO interface.
<b>LED:</b> Drive Status	<b>AMP:</b> Bi-Color LED		
*For status indicator locations and codes, see <a href="#">Status Indicators (p. 38)</a> .			

Model	XE2/800-1818/800-1819	XP2	XM2
<b>LED:</b> Network Status	<b>RUN</b> EtherCAT State Machine (ESM) status per ETG 1300 S(R) V1.0.1 <b>ERR</b> Error status & warnings <b>L/A</b> Link/Act shows state of the EtherCAT network	<b>RUN</b> CANopen Finite State Automaton (FSA) status <b>ERR</b> Error status & warnings <b>L/A</b> Link/Act shows state of the CANopen network	<b>NET</b> Two Bi-Color LEDs. Each dedicated to the status of the MACRO interface of one axis.
<b>LED:</b> Drive Status	<b>AMP</b> Two Bi-Color LEDs. Each dedicated to one axis.		
*For status indicator locations and codes, see <a href="#">Status Indicators (p. 38)</a> .			

### 3.21: Fault Levels

Amp Over Temperature	> 80 °C
DC Bus Under Voltage	< +60 Vdc
DC Bus Over Voltage	> +400 Vdc
Encoder Power	< +4.25 Vdc
AC Loss Detection	Loss of mains voltage between L1 & L2 pins of J1

### 3.22: Power Dissipation

Model:		XEL-230-18 (-R)	XEL-230-36 (-R)	XEL-230-40 (-R)
Output Power	Mains Voltage	XPL-230-18 (-R)	XPL-230-36 (-R)	XPL-230-40 (-R)
		XML-230-18 (-R)	XML-230-36 (-R)	XML-230-40 (-R)
Maximum Continuous	120 Vac	30 W	55 W	92 W
	240 Vac	40 W	75 W	120 W

Single Axis Power Dissipation

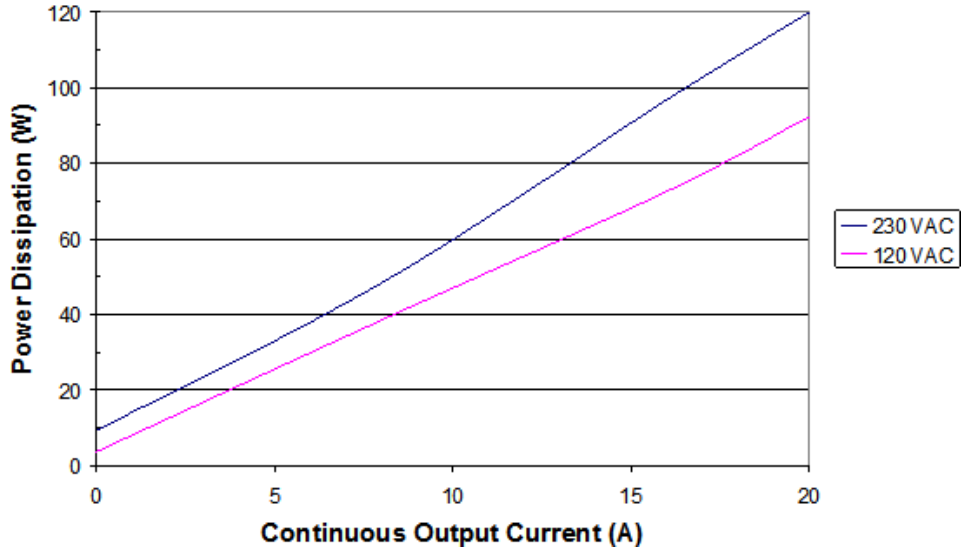

### 3.23: Thermal Impedance

See [Thermal Considerations](#) (p. 141).

### 3.24: Mechanical and Environmental

#### XEL/XPL/XML

Size	7.92 in (201,2 mm) X 5.51 in (139,9 mm) X 2.31 in (58,7 mm)
Weight	
Driver without Heat Sink	3.0 lb (1.36 kg)
Low profile (-HL) Heat Sink	Add 1.86 lb (0.84 kg)
Standard (-HS) Heat Sink	Add 3.1 lb (1.40 kg)
Ambient Temperature	
Storage	-40 to +85°C
Operating	0 to +45°C
Humidity	0% to 95%, non-condensing
Contaminants	Pollution degree 2
Environment	IEC68-2: 1990
Cover Material	Meets U.L. Spec 94 V-0 Flammability Rating
Cooling	Heat sink and/or forced air cooling required for continuous power output

#### XE2/XP2/XM2/800-1818/800-1819

Size	XE2/XP2/XM2/800-1819: 9.24 in (234,7 mm) X 5.42 in (137,6 mm) X 3.59 in (91,1 mm) 800-1818: 9.24 in (234,7 mm) X 5.57 in (141,6 mm) X 2.31 in (58,7 mm)
Weight	XE2/XP2/XM2/800-1819: 4.19 lb (1.90 kg) 800-1818: 3.13 lb (1.42 kg)
Ambient Temperature	
Storage	-40 to +85°C
Operating	0 to +40°C
Humidity	0% to 95%, non-condensing
Contaminants	Pollution degree 2
Ingress Protection	IP20
Vibration	2 g peak, 10~500 Hz (sine), IEC60068-2-6
Shock	10 g, 10 ms, half-sine pulse, IEC60068-2-27
Environment	IEC68-2: 1990
Cooling	XE2/XP2/XM2/800-1819: Integrated heatsink and cooling fan provide required cooling 800-1818: Dependent on mounting orientation and ambient airflow



### 3.25: Dimensions

#### 3.25.1: XEL/XPL Dimensions

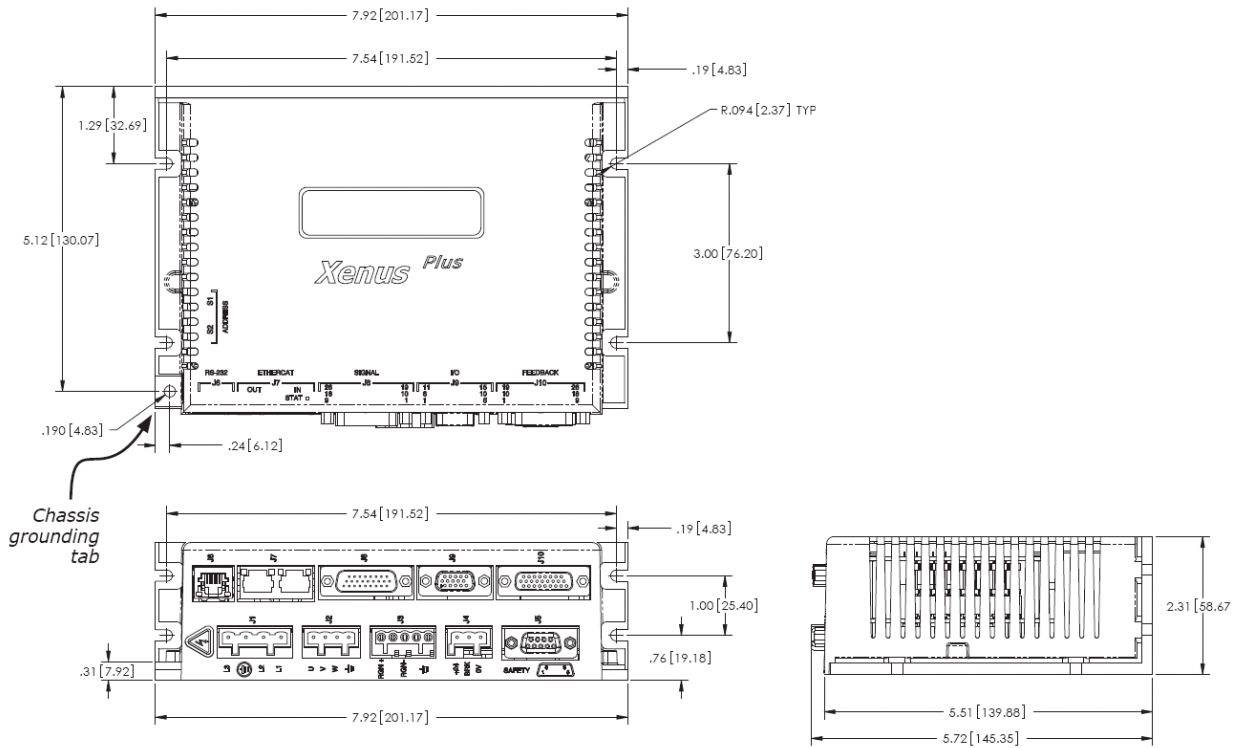

#### 3.25.2: XML Dimensions

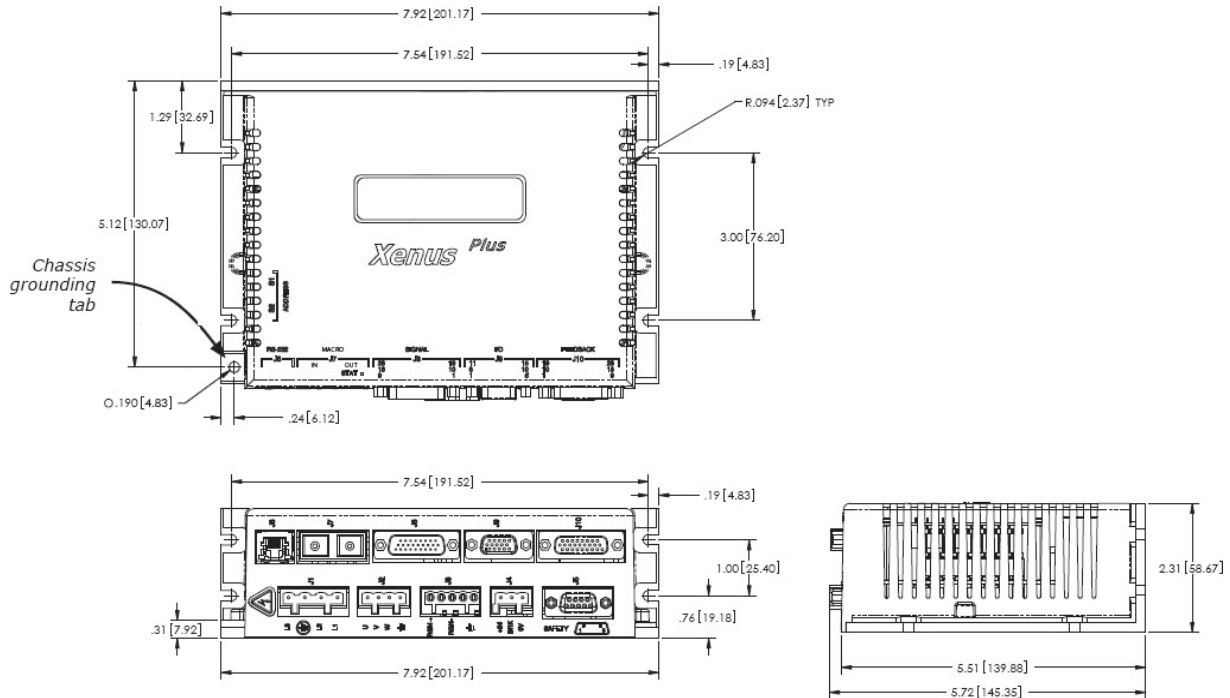

**3.25.3: XE2/XP2/XM2/800-1819 Dimensions**

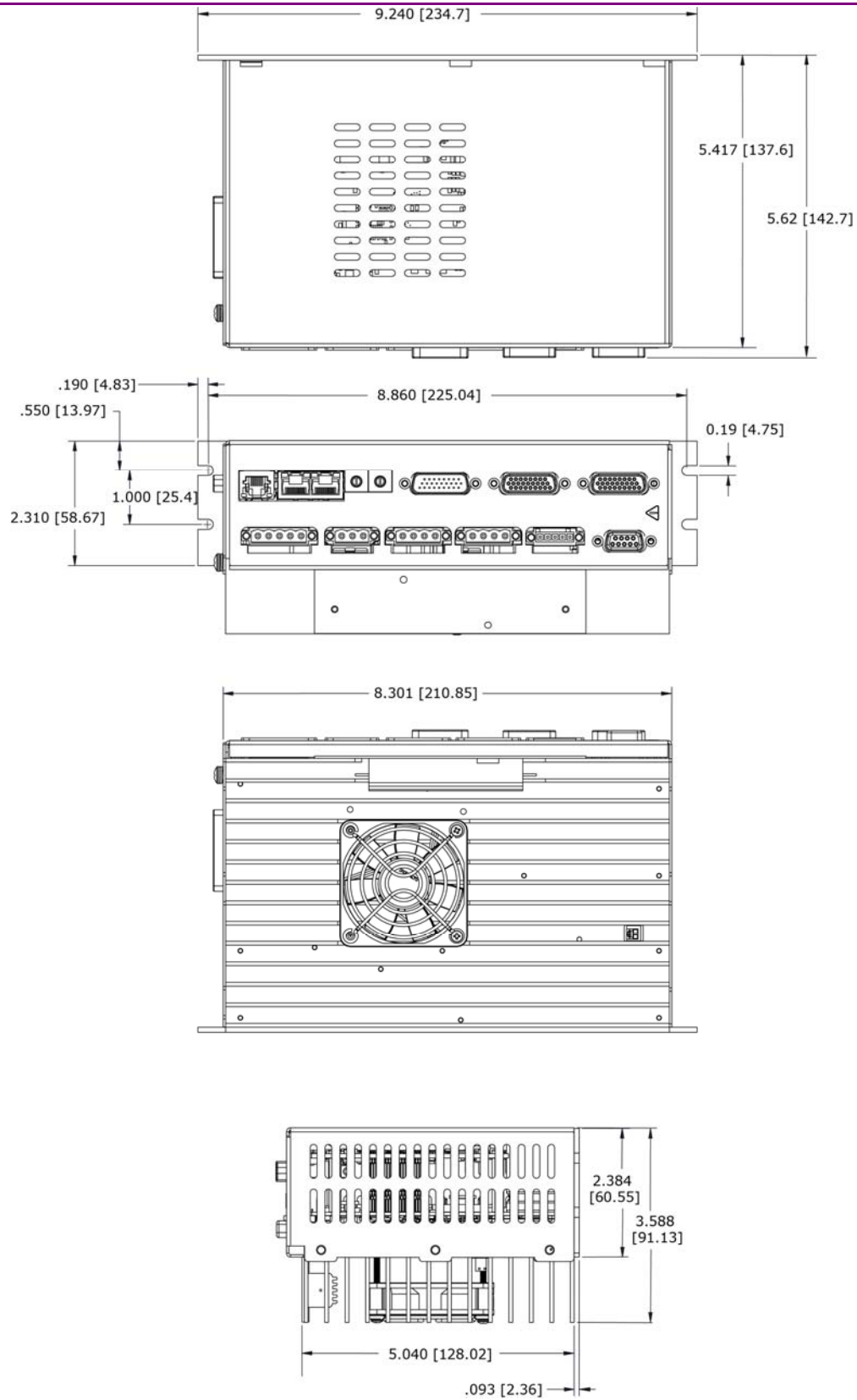

3.25.4: 800-1818 Dimensions

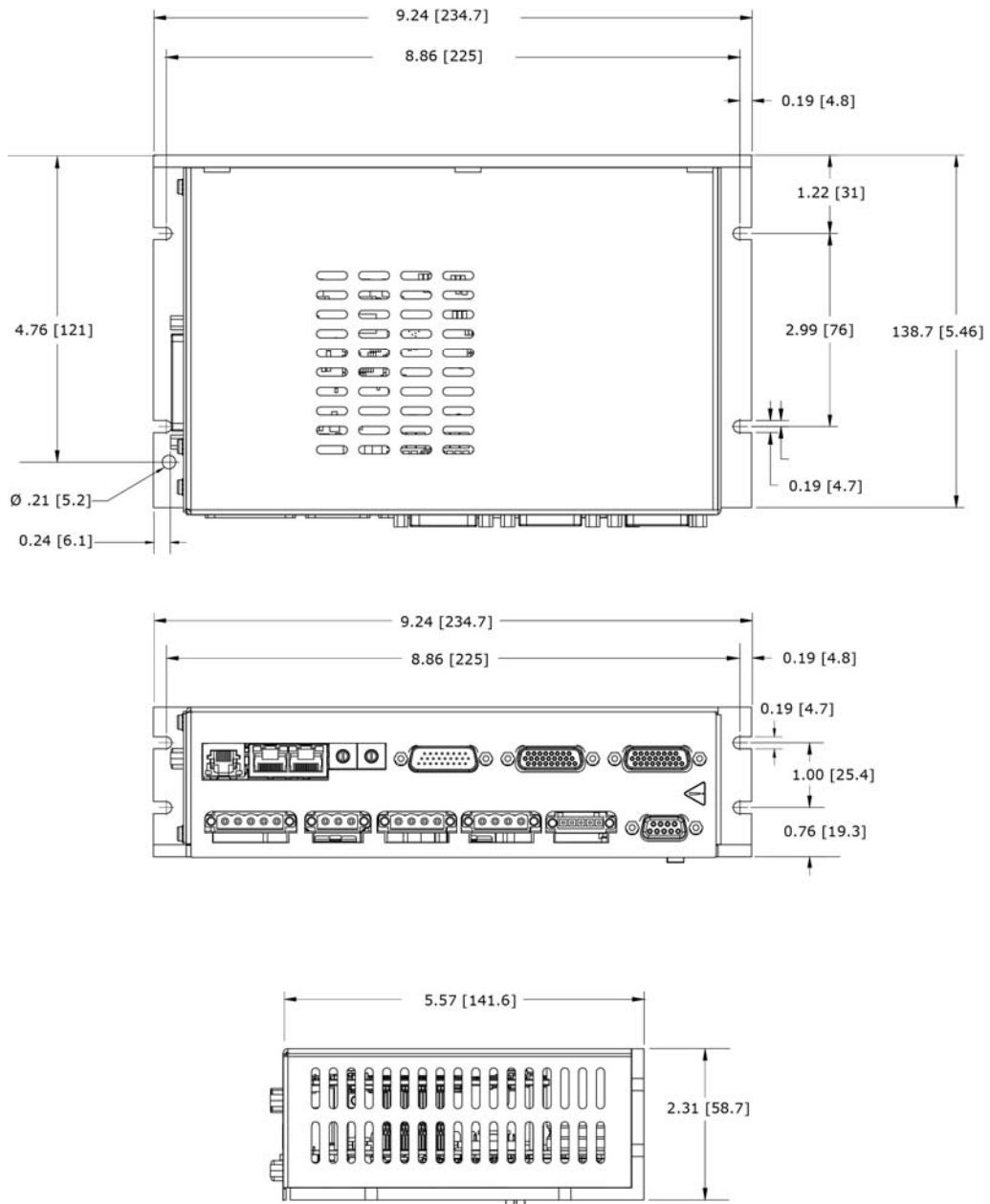

# CHAPTER

## 4: WIRING









This chapter describes the wiring of drive and motor connections. Contents include:

4.1: General Wiring Instructions .....	85
4.2: AC Mains (J1) .....	88
4.3: Motor(s) .....	91
4.4: Regen Resistor (Optional) .....	93
4.5: Logic Supply / Brake .....	96
4.6: Ferrules – XE2/XP2/XM2/800-1819 .....	98
4.7: Safe Torque Off .....	99
4.8: RS-232 Serial Communications .....	103
4.9: Network Ports .....	104
4.10: Control I/O .....	107
4.11: Motor Feedback .....	123

## 4.1: General Wiring Instructions

### 4.1.1: Electrical Codes and Warnings

Be sure that all wiring complies with the National Electrical Code (NEC) or its national equivalent, and all prevailing local codes.

 <b>DANGER</b>	<b>DANGER: Hazardous voltages.</b>				
	Exercise caution when installing and adjusting. <b>Failure to heed this warning can cause equipment damage, injury, or death.</b>				
 <b>DANGER</b>	<b>Risk of electric shock.</b>				
	High-voltage circuits connected to mains power.				
	<table border="1" style="width: 100%;"> <tr> <td style="width: 60%;">XEL/XPL/XML</td> <td>J1, J2, J3</td> </tr> <tr> <td>XE2/XP2/XM2/800-1818/800-1819</td> <td>J1, J2, J3, and J4</td> </tr> </table>	XEL/XPL/XML	J1, J2, J3	XE2/XP2/XM2/800-1818/800-1819	J1, J2, J3, and J4
XEL/XPL/XML	J1, J2, J3				
XE2/XP2/XM2/800-1818/800-1819	J1, J2, J3, and J4				
<b>Failure to heed this warning can cause equipment damage, injury, or death.</b>					
 <b>DANGER</b>	<b>Refer to the Xenus Plus Dual-Axis STO User Manual</b>				
	The information provided in the Xenus Plus Dual-Axis STO User Manual must be considered for any application using the XE2/XP2/XM2/800-1818/800-1819 drive STO feature. <b>Failure to heed this warning can cause equipment damage, injury, or death.</b>				
 <b>WARNING</b>	<b>Do not plug or unplug connectors with power applied.</b>				
	The connecting or disconnecting of cables while the drive has 24Vdc and/or mains power applied is not recommended. <b>Failure to heed this warning may cause equipment damage.</b>				
 <b>WARNING</b>	<b>Do not ground mains-connected circuits.</b>				
	Do not ground Mains connected circuits: J1, J2, J3 and J4 for XE2/XP2/XM2/800-1818/800-1819; J1, J2 and J3 for XEL/XPL/XML. <b>Failure to heed this warning can cause equipment damage.</b>				
 <b>WARNING</b>	<b>Risk of Radio Frequency Interference</b>				
	The Xenus Plus Dual Axis drives are not intended for use on a low-voltage public network which supplies domestic premises. Radio frequency interference should be expected if used on such a network				
 <b>WARNING</b>	<b>EMI Line Filter is necessary to meet EMC requirements</b>				
	Use if an EMI Line Filter with Xenus Plus Dual Axis drives is mandatory for meeting EMC requirements				
 <b>WARNING</b>	<b>A surge protection device (SPD) is required to establish an over-voltage category II environment</b>				
	The AC mains supplying the XE2/XP2/XM2/800-1818/800-1819 drives must be limited to over-voltages of Category II. The relevant standards assume AC mains with over-voltages per OVC III. An SPD is required to limit over-voltages to OVC II levels.				

---

## 4.1.2: Grounding Considerations

---

### Primary Grounding Functions

A grounding system has three primary functions: electrical safety, voltage-reference, and shielding.

### J1-3 Protective Earth Ground

The protective earth (PE) ground at J1-3 (for both single and dual axis drives), is the electrical safety ground and is intended to carry the fault currents from the mains in the case of an internal failure or short-circuit of electronic components. This ground is connected to the drive chassis. Wiring to this ground should be done using the same gauge wire as that used for the mains. This wire is a “protective bonding” conductor that should be connected to an earthed ground point and must not pass through any circuit interrupting devices.

### J2 Regen and J3 Motor Connector Grounds

On Xenus Plus Single Axis drives, the ground terminals at J2-1 and J3-5 connect to the drive chassis.

On Xenus Plus Dual Axis drives, the ground terminals at J2-3 and J3/J4-1 connect to the drive chassis.

These ground terminals are provided as cable shield and protective earth connection points for the motor and regen resistor cables. Connection of cable shields to these points is made to provide electrical noise reduction. Connection of motor or regen cable protective earth conductors to these points is made to prevent the motor or regen resistor housing from becoming hazardous live in the event of an insulation failure. Protective earth connections for the motor and regen resistor housings are subject to local electrical codes and must be reviewed for compliance with those codes. It is the responsibility of the end user to ensure compliance with local electrical codes and any other applicable standards. It is strongly recommended that motor and regen resistor housings also be connected to protective earth connection points located as close to the motor and regen resistor as possible. In many applications, the machine frame is used as a primary or supplemental protective earth connection point for the motor and regen resistor housings.

### Signal Grounding

The drive signal ground must be connected to the control system signal ground. The drive signal ground is not connected to earth ground internal to the drive. Therefore, the control system signal ground can be connected to earth ground without introducing a ground loop.

### Cable Shielding

Shields on cables reduce emissions from the drive and help protect internal circuits from interference due to external sources of electrical noise. The shields shown in the wiring diagrams are also required for CE compliance. Cable shields should be tied at both ends to earth or chassis ground. The housing and pin 1 of J8, J9, and J10 (J9 - J12 for XE2/XP2/XM2/800-1819), are connected to the drive’s chassis.

Feedback cables with inner/outer shielding should connect the outer shield to the motor and drive frame grounds. The inner shield should connect to Signal Ground on the drive and be unconnected at the encoder or resolver.

**Connector Locations**

Connector locations for 1-axis models are shown below.



Connector locations for 2-axis models, are shown below. Note: J1 is on the upper end-panel.



## 4.2: AC Mains (J1)

### 4.2.1: XEL/XPL/XML

#### Mating Connector

Description	Euro-style 7.5 mm pluggable female terminal block with preceding ground receptacle.
Manufacturer PN	Wago: 721-204/026-045 (Note 1)
Wire size	22 - 12 AWG
Recommended Wire	18 A models: 14 AWG, 600 V 20 A, 36 A and 40 A models: 12 AWG, 600 V Shielded cable required for CE compliance
Wire Insertion/Extraction Tool	Wago: 231-131
Connector and tool are included in Connector Kits XEL-CK, XML-CK, and XPL-CK.	

Note 1: For RoHS compliance, append “/RN01-0000” to the part numbers listed above.

#### Pin Description

Pin	Signal	Function
1	L1	AC power input (hot or L1)
2	L2	AC power input (neutral or L2)
3	Protective ground	Chassis safety ground
4	L3	AC power input (L3)

#### AC Mains Fuse Recommendation (All Xenus Plus models)

Recommended fuse type: Class CC, 600 Vac rated, Ferraz-Shawmut ATDR, Littelfuse CCMR, Bussman LP-CC, or equivalent.

#### AC Mains Wiring Diagram (Single-Phase) XEL/XPL/XML

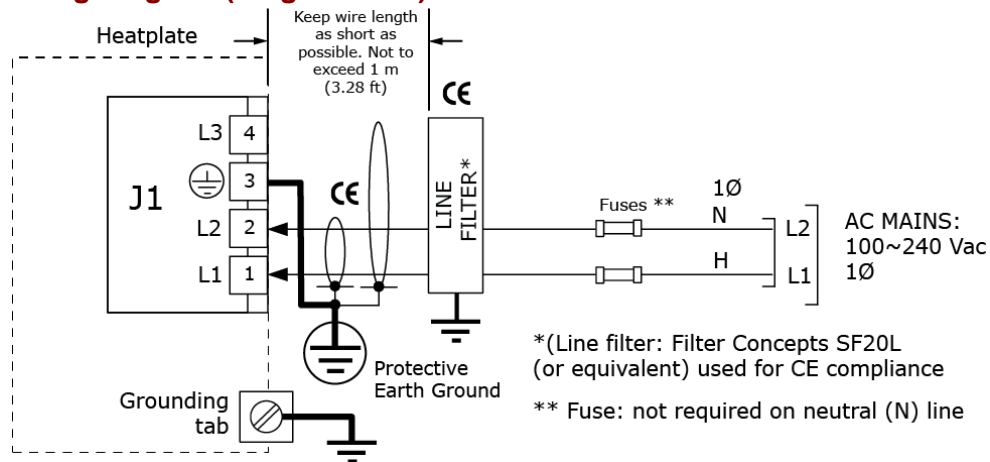



**AC Mains Wiring Diagram (Three-Phase) XEL/XPL/XML**

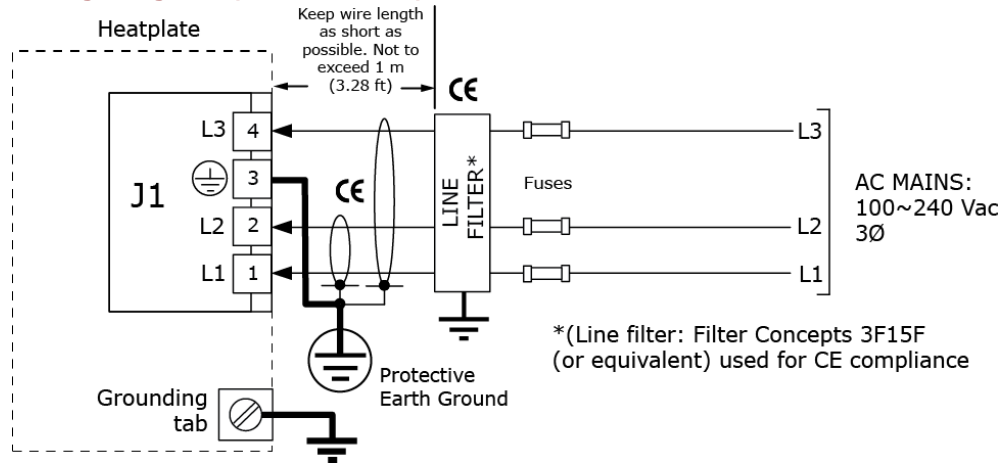

**4.2.2: XE2/XP2/XM2/800-1818/800-1819**

**Mating Connector**

Description	Euro-style 5.08 mm pluggable female terminal block.
Manufacturer PN	Wago: 231-305/107-000 (Note 1)
Wire size	22 - 12 AWG
Recommended Wire	12 AWG, 600 V Shielded cable required for CE compliance
Wire Insertion/Extraction Tool	Wago: 231-131 or 231-291
Connector and tool are included in Connector Kits XE2-CK, XP2-CK and XM2-CK.	

Note 1: For RoHS compliance, append “/RN01-0000” to the part numbers listed above.

**Pin Description**

Pin	Signal	Function
1	L1	AC power input (hot or L1)
2	L2	AC power input (neutral or L2)
3	PE ground	Chassis safety ground
4	Frame ground	Frame ground
5	L3	AC power input (L3)

**AC Mains Fuse Recommendation (All Xenus Plus models)**

Recommended fuse type: Class CC, 600 Vac rated, Ferraz-Shawmut ATDR, Littelfuse CCMR, Bussman LP-CC, or equivalent.

 <b>WARNING</b>	<b>EMI Line Filter is necessary to meet EMC requirements</b>
	Use if an EMI Line Filter with Xenus Plus Dual Axis drives is mandatory for meeting EMC requirements
 <b>WARNING</b>	<b>A surge protection device (SPD) is required to establish an over-voltage category II environment</b>
	The AC mains supplying the drive must be limited to over-voltages of Category II. The relevant standards assume AC mains with over-voltages per OVC III. An SPD is required to limit over-voltages to OVC II levels.

**AC Mains Wiring Diagram (Single-Phase) XE2/XP2/XM2/800-1818/800-1819**

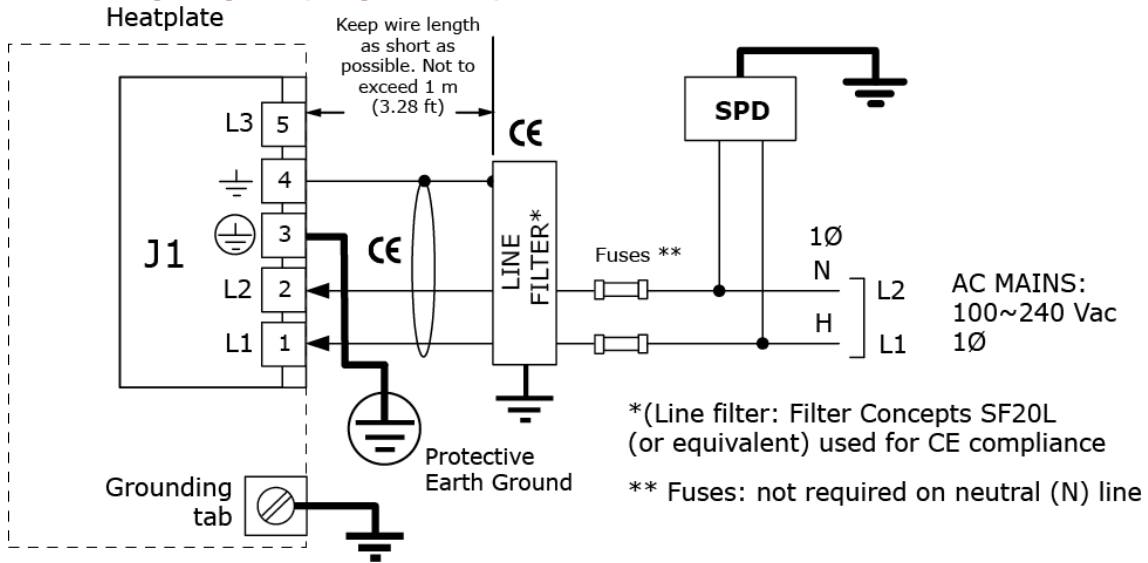

**AC Mains Wiring Diagram (Three-Phase) XE2/XP2/XM2/800-1818/800-1819**

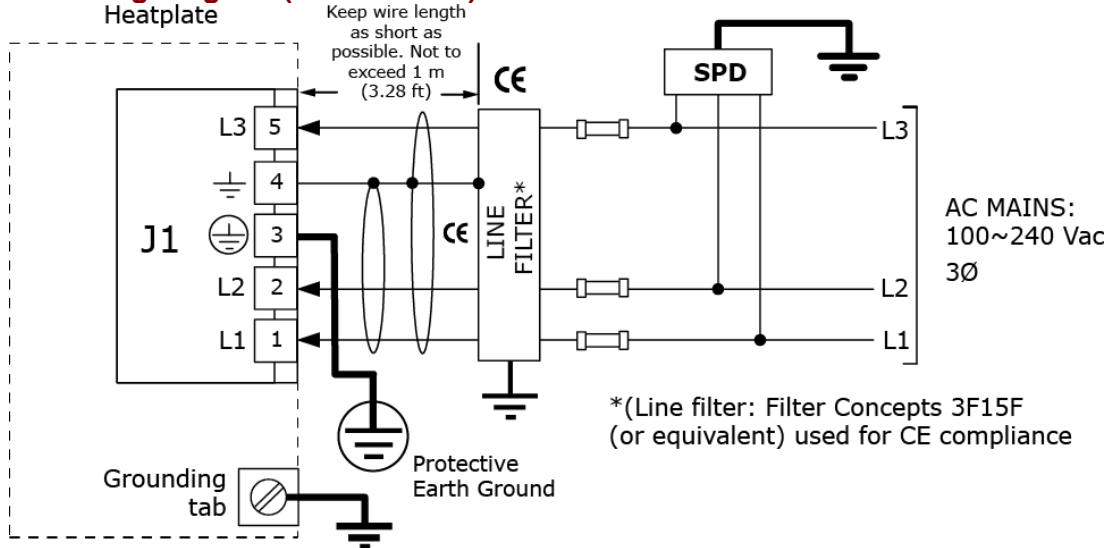

In the end product installation, a UL RC (Recognized Component) SPD (Surge Protective Device) type 1CA, 2CA, 3CA or a UL Listed (VZCA) SPD type 1, 2, or 3 rated 2500 V, with a minimum SCCR of 5 kA, 240 Vac, and surge voltage monitoring needs to be provided. The purpose of the SPD is to establish an over-voltage CAT II environment. Example parts are Cooper Bussman BSPM3240DLG (3 phase) or BSPM2240S3G (two-polel).

In order to minimize electrical noise it is important to keep the connection between the drive heatplate and earth/equipment frame as short as possible. An unplated tab on the drive heatplate is provided for making this connection. This tab also provides a connection point for a second protective earthing conductor to address the touch current requirements of IEC 61800-5-1.

The Xenus Plus Dual Axis models use a diode rectifier and DC bus capacitance to convert the incoming AC mains voltage to DC for powering the output stage inverter. Depending on actual drive load conditions, the total harmonic distortion (THD) of the current drawn from the AC mains can exceed 10%. Management of current THD must be considered in the overall system and harmonic filtering may be required. Users should refer to Clause B.4 of IEC 61800-3:2004+A1:2011 for further details.

In the presence of commutation notch disturbances on the incoming AC mains, the DC bus voltage in the Xenus Plus Dual Axis models can exceed the overvoltage shutdown level (400V). In the event that commutation notches result in DC bus voltages above the overvoltage shutdown threshold in the end use system, measures to reduce commutation notch disturbances may be required.

## 4.3: Motor(s)

### 4.3.1: (J2) XEL/XPL/XML

#### Mating Connector

Description	Euro-style, 4 position, 5.0 mm pluggable female terminal block
Manufacturer PN	Wago: 721-104/026-047 (Note 1)
Wire Size	22 - 12 AWG
Recommended Wire	18 A models: 14 AWG, 600 V 20 A, 36 A and 40 A models: 12 AWG, 600 V Shielded cable required for CE compliance
Wire Insertion/Extraction Tool	Wago: 231-131
Standard connector and tool are included in Connector Kits XEL-CK, XML-CK, and XPL-CK.	

Note 1: For RoHS compliance, append "/RN01-0000" to the part numbers listed above.

#### Pin Description

Pin	Signal	Function
1	Ground	Motor frame ground and cable shield
2	W	Phase W output of drive
3	V	Phase V output of drive (use for DC motor connection)
4	U	Phase U output of drive (use for DC motor connection)

#### Brushless Motor Wiring Diagram

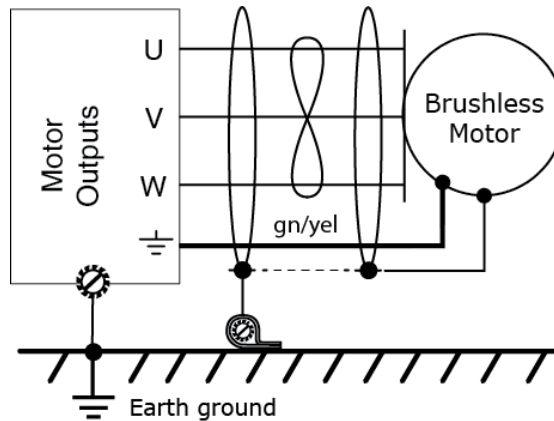

#### Brush Motor Wiring Diagram

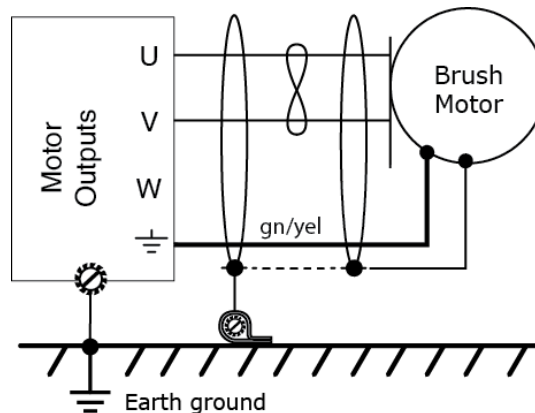

**4.3.2: (J3, J4) XE2/XP2/XM2/800-1818/800-1819**

**Mating Connector**

Description	Euro-style, 4 position, 5.08 mm pluggable female terminal block
Manufacturer PN	Wago: 231-304/107-000 (Note 1)
Wire Size	22 - 12 AWG
Recommended Wire	12 AWG, 600 V Shielded cable required for CE compliance
Wire Insertion/Extraction Tool	Wago: 231-131 or 231-291
Standard connector and tool are included in Connector Kits XE2-CK, XM2-CK, and XP2-CK.	

Note 1: For RoHS compliance, append "/RN01-0000" to the part numbers listed above.

**Pin Description**

Pin	Signal	Function
1	Ground	Motor frame ground and cable shield
2	W	Phase W output of drive
3	V	Phase V output of drive (use for DC motor connection)
4	U	Phase U output of drive (use for DC motor connection)

**Brushless Motor Wiring Diagram**

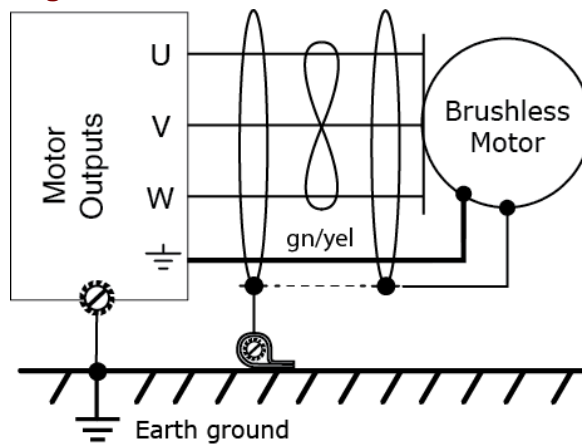

**Brush Motor Wiring Diagram**

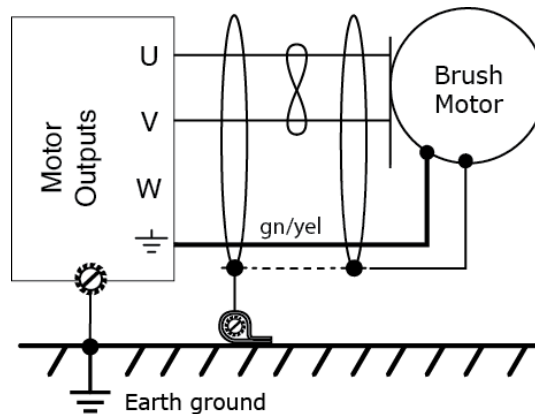

## 4.4: Regen Resistor (Optional)

### 4.4.1: (J3) XEL/XPL/XML

#### Mating Connector

Description	Euro-style, 5 position, 5.0 mm pluggable male terminal block.
Manufacturer PN	Wago: 721-605/000-044 (Note 1)
Wire Size	22 - 12 AWG
Recommended Wire	18 A models: 14 AWG, 600 V 36 A and 40 A models: 12 AWG, 600 V Shielded cable required for CE compliance
Wire Insertion/Extraction Tool	Wago: 231-131
Standard connector and tool are included in Connector Kits XEL-CK, XML-CK, and XPL-CK.	

Note 1: For RoHS compliance, append "/RN01-0000" to the part numbers listed above.

#### Pin Description

Pin	Signal	Function
1	Regen +	+ DC Bus to one side of regen resistor
2	N/C	No connection
3	Regen -	Collector of regen transistor to one side of regen resistor
4	N/C	No connection
5	Ground	Enclosure ground and cable shield

#### Regen Resistor Wiring Diagram

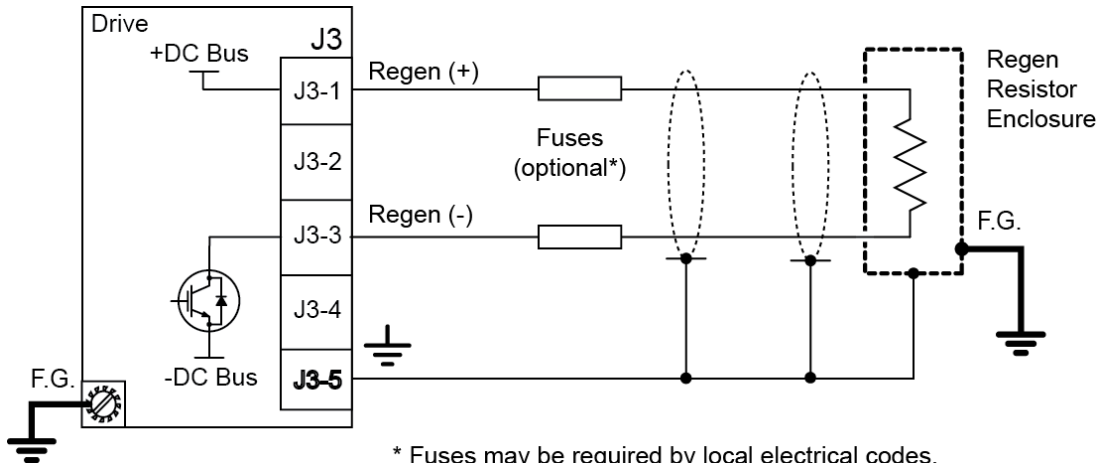

#### Regen Resistor Fusing

Recommended Fuses:

Regen Resistor	Fuse type
XTL-RA-03	Cooper Bussman KLM-8, Littelfuse KLKD008, Ferraz Shawmut ATM-10 or equivalent.
XTL-RA-04	Cooper Bussman KLM-12, Littelfuse KLKD012, Ferraz Shawmut ATM-15 or equivalent.
User Supplied	See <a href="#">Regen Resistor Sizing and Configuration</a> (p. 132).

**4.4.2: (J2) XE2/XP2/XM2/800-1819**

With the exception of model 800-1818, the Xenus Plus Dual Axis models are provided with an integrated regen resistor that is pre-wired and connected to J2. If a given application requires a higher capacity regen resistor, then the user may disconnect the integrated resistor from J2 and connect an external resistor instead. An external regen resistor may be used with model 800-1818. Connection details for both the integrated and external regen resistors are provided as follows.

**Mating Connector**

Description	Euro-style, 3 position, 5.08 mm pluggable female terminal block.
Manufacturer PN	Wago: 231-303/107-000 (Note 1)
Wire Size	22 - 12 AWG
Recommended Wire	12 AWG, 600 V Shielded cable required for CE compliance
Wire Insertion/Extraction Tool	Wago: 231-131 or 231-291
Standard connector and tool are included in Connector Kits XE2-CL, XP2-CK and XM2-CK.	

Note 1: For RoHS compliance, append "/RN01-0000" to the part numbers listed above.

**Pin Description**

Pin	Signal	Function
1	Regen +	+ DC Bus to one side of regen resistor
2	Regen -	Collector of regen transistor to one side of regen resistor
3	Frame ground	Enclosure ground and cable shield

	<p><b>The mating connector must be installed at location J2 regardless of whether a regen resistor is connected</b></p>
<p><b>WARNING</b></p>	<p>A mating connector must be installed at location J2 whenever AC mains power is applied and within the capacitor discharge time. Otherwise the terminals of J2 are exposed and present a shock hazard under these conditions.</p>

**Wiring Diagram – Integrated Regen Resistor**

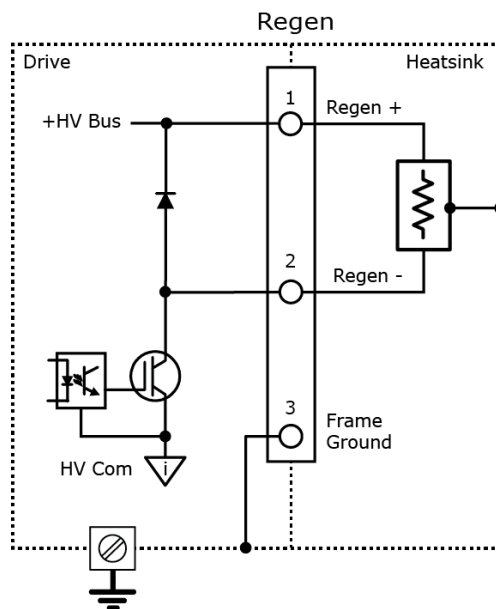

**Wiring Diagram – External Regen Resistor**

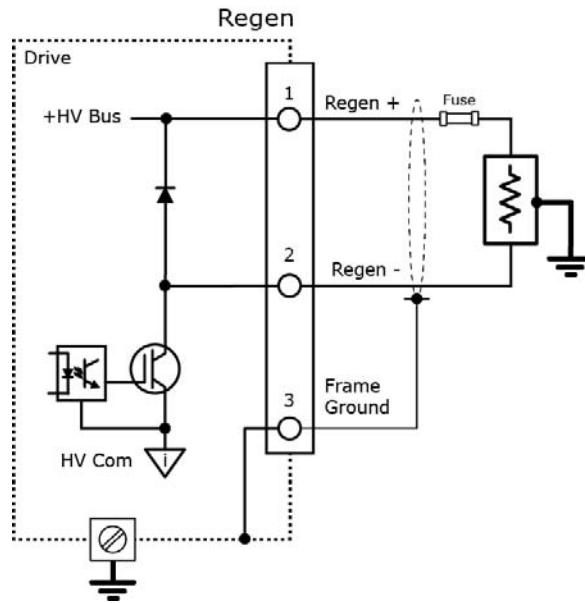

**Regen Resistor Fusing – External Regen Resistor**

Recommended Fuses:

<b>Regen Resistor</b>	<b>Fuse type</b>
XTL-RA-03	Cooper Bussman KLM-8, Littelfuse KLKD008, Ferraz Shawmut ATM-10 or equivalent.
XTL-RA-04	Cooper Bussman KLM-12, Littelfuse KLKD012, Ferraz Shawmut ATM-15 or equivalent.
User Supplied	See <a href="#">Regen Resistor Sizing and Configuration (p. 132)</a> .

## 4.5: Logic Supply / Brake

### 4.5.1: XEL/XPL/XML (J4)

The following information is for XEL/XPL/XML drives only.

#### Mating Connector

Description	Euro-style, 3 position, 5.0 mm pluggable female terminal block.
Manufacturer PN	Wago: 721-103/026-047 (Note 1)
Wire Size	22 - 14 AWG
Recommended Wire	18 AWG
Wire Insertion/Extraction Tool	Wago: 231-131
Standard connector and tool are included in Connector Kits XEL-CK, XML-CK, and XPL-CK.	

Note 1: For RoHS compliance, append "/RN01-0000" to the part numbers listed above.

#### Pin Description

Pin	Signal	Function
1	RTN	+24 Vdc return
2	Brake	Return or low side of motor brake
3	+24 Vdc	+24 Vdc Logic power supply

#### Logic Supply / Brake Wiring Diagram

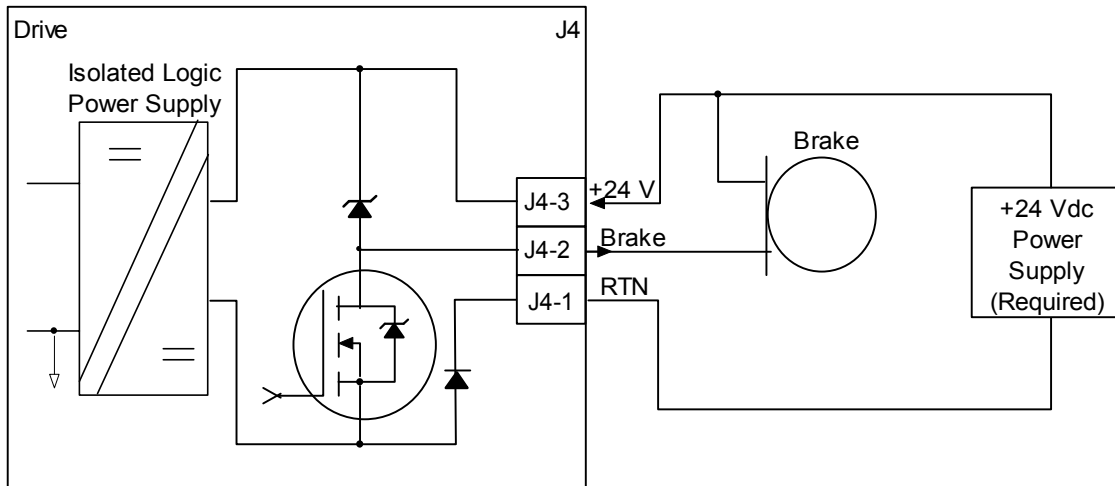



**4.5.2: XE2/XP2/XM2/800-1818/800-1819 (J5)**

The following information is for XE2/XP2/XM2/800-1819 drives only.

**Mating Connector**

Description	Euro-style 3.5 mm, 5 position pluggable female terminal block.
Manufacturer PN	Wago: 734-105/107-000 (Note 1)
Wire Size	28 - 14 AWG
Recommended Wire	18 AWG
Wire Insertion/Extraction Tool	Wago: 734-191
Standard connector and tool are included in Connector Kits XE2-CK, XP2-CK and XM2-CK.	

Note 1: For RoHS compliance, append "/RN01-0000" to the part numbers listed above.

**Pin Description**

Pin	Signal	Function
1	RTN	+24 Vdc Logic power supply return
2	Brake B	Return or low side of motor brake B.
3	Brake A	Return or low side of motor brake A.
4	Brake+24 Vdc	+24 Vdc for both brakes.
5	24 Vdc input	+24 Vdc Logic power supply

**Logic Supply / Brake Wiring Diagram**

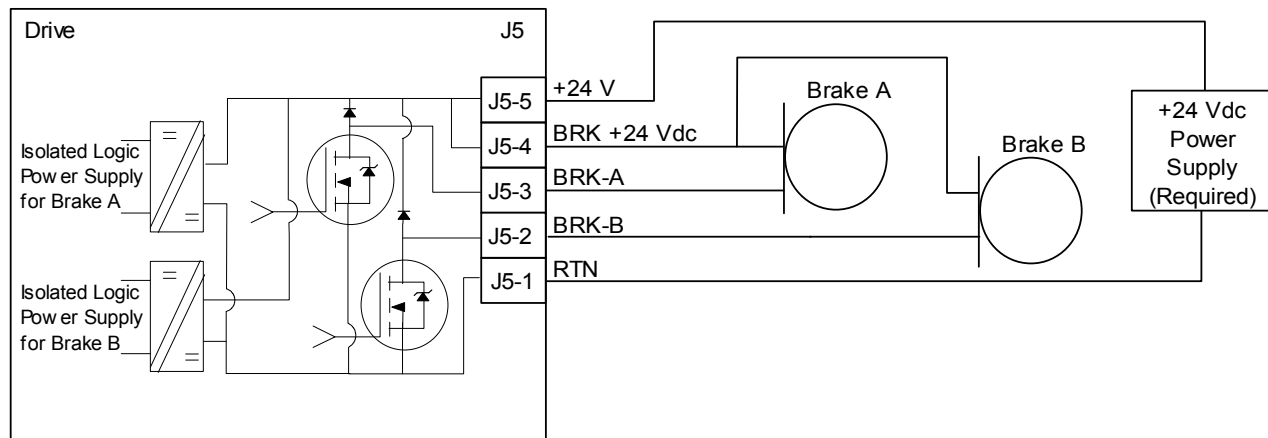

Note that the +24Vdc supply must be a SELV or PELV type in applications using the XE2/XP2/XM2 STO feature. See the *Xenus Plus Dual-Axis STO Manual* for further details.

## 4.6: Ferrules – XE2/XP2/XM2/800-1818/800-1819

### AC POWER, REGEN AND MOTOR OUTPUTS: J1~J4

Wago MCS-MIDI Classic: 231-305/107-000 (J1) 231-303/107-000 (J2), 231-304/107-000 (J3, J4), female connector; with screw flange; pin spacing 5.08 mm / 0.2 in

Conductor capacity  
 Bare stranded: AWG 28~14 [0.08~2.5 mm<sup>2</sup>]  
 Insulated ferrule: AWG 24~16 [0.25~1.5 mm<sup>2</sup>]  
 Stripping length: 8~9 mm  
 Operating Tool: Wago MCS-MIDI Classic: 231-291

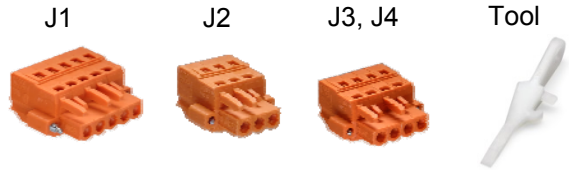

AWG	mm <sup>2</sup>	Color	Mfgr	PNUM	A	B	C	D	E	SL
14	2.5	Blue	Wago	216-206	15.0 (.59)	8.0 (0.31)	2.05 (.08)	4.2 (0.17)	4.8 (0.19)	10 (0.39)
16	1.5	Black	Wago	216-204	14.0 (0.59)	8.0 (0.31)	1.7 (.07)	3.5 (0.14)	4.0 (0.16)	10 (0.39)
18	1.0	Red	Wago	216-223	12.0 (.47)	6.0 (.24)	1.4 (.055)	3.0 (.12)	3.5 (.14)	8 (.31)
	0.75	Gray	Wago	216-222	12.0 (.47)	6.0 (.24)	1.2 (.047)	2.8 (.11)	3.3 (.13)	8 (.31)
22	0.5	White	Wago	216-221	12.0 (.47)	6.0 (.24)	1.0 (.039)	2.6 (.10)	3.1 (.12)	7.5 (.30)

#### NOTES

PNUM = Part Number  
 SL = Stripping length  
 Dimensions: mm (in)

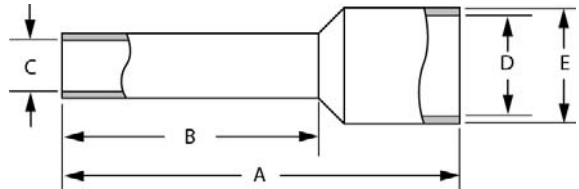

### 24V & BRAKE: J5

Wago MCS-MINI: 734-105/107-000, female connector; with screw flange, pin spacing 3.5 mm / 0.138 in

Conductor capacity  
 Bare stranded: AWG 28~16 [0.08~1.5 mm<sup>2</sup>]  
 Insulated ferrule: AWG 24~16 [0.25~1.5 mm<sup>2</sup>]  
 Stripping length: 0.24~0.28 in [6~7 mm]  
 Operating tool: Wago MCS-MINI: 734-191



### FERRULE PART NUMBERS: SINGLE-WIRE INSULATED

AWG	mm <sup>2</sup>	Color	Mfgr	PNUM	A	B	C	D	E	SL
18	1.0	Red	Wago	216-223	12.0 (.47)	6.0 (.24)	1.4 (.06)	3.0 (.12)	3.5 (.14)	8 (.31)
20	0.75	Gray	Wago	216-222	12.0 (.47)	6.0 (.24)	1.2 (.05)	2.8 (.11)	3.3 (.13)	8 (.31)
22	0.5	White	Wago	216-221	12.0 (.47)	6.0 (.24)	1.0 (.04)	2.6 (.10)	3.1 (.12)	7.5 (.30)

### FERRULE PART NUMBERS: DOUBLE-WIRE INSULATED

AWG	mm <sup>2</sup>	Color	Mfgr	PNUM	A	B	C	D	E	SL
2 x 18	2 x 1.0	Red	Altech	2776.0	15.4 (.61)	8.2 [.32]	2.4 (.09)	3.2 (.13)	5.8 (.23)	11.0 (.43)
2 x 18	2 x 1.0	Gray	Altech	2775.0	14.6 (.57)	8.2 (.32)	2.0 (.08)	3.0 (.12)	5.5 (.22)	11.0 (.43)
2 x 20	2 x 0.75	White	Altech	2794.0	14.6 (.57)	8.2 (.32)	1.7 (.07)	3.0 (.12)	5.0 (.20)	11.0 (.43)
2 x 20	2 x 0.75	Gray	TE	966144-2	15.0 (.59)	8.0 (.31)	1.70 (.07)	2.8 (.11)	5.0 (.20)	10 (.39)
2 x 22	2 x 0.50	White	TE	966144-1	15.0 (.59)	8.0 (.31)	1.40 (.06)	2.5 (.10)	4.7 (.19)	10 (.39)

#### SINGLE WIRE

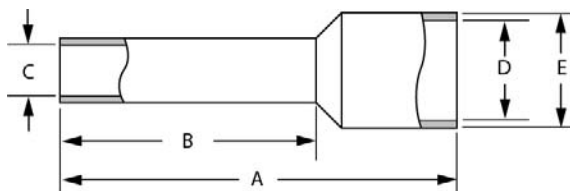

#### DOUBLE WIRE

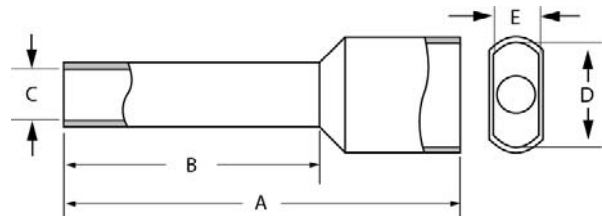

## 4.7: Safe Torque Off

### 4.7.1: XEL/XPL/XML (J5)

The following information is for XEL and XPL drives only.

#### Mating Connector

Description	Manufacturer PN	Wire Size
Connector, D-Sub, 9-position, male, solder cup	Norcomp: 171-009-103L001	
Backshell, D-Sub, RoHS, metallized, for above	Norcomp: 979-009-020R121	24-20AWG

#### Pin Description

Pin	Signal	Function
1	Frame Ground	Cable shield connection.
2	STO-1(+)	High Side STO inputs.
3	STO-1(-)	
4	STO-2(+)	Low Side STO inputs.
5	STO-2(LO-)	
6	STO LED(+)	PWM outputs state LED outputs.
7	STO-LED(-)	
8	STO-GND	Signal ground.
9	STO-24V	Internal current source for STO bypassing

**Safe Torque Off Wiring Diagram (XEL/XPL/XML)**

NOTE: The diagram below includes the STO bypass connections that will energize both STO-1 and STO-2 inputs. When this is done the STO feature is de-activated and control of the output PWM stage is under control of the digital control core. If not using the STO feature, these connections must be made in order for the Xenus Plus to be enabled.

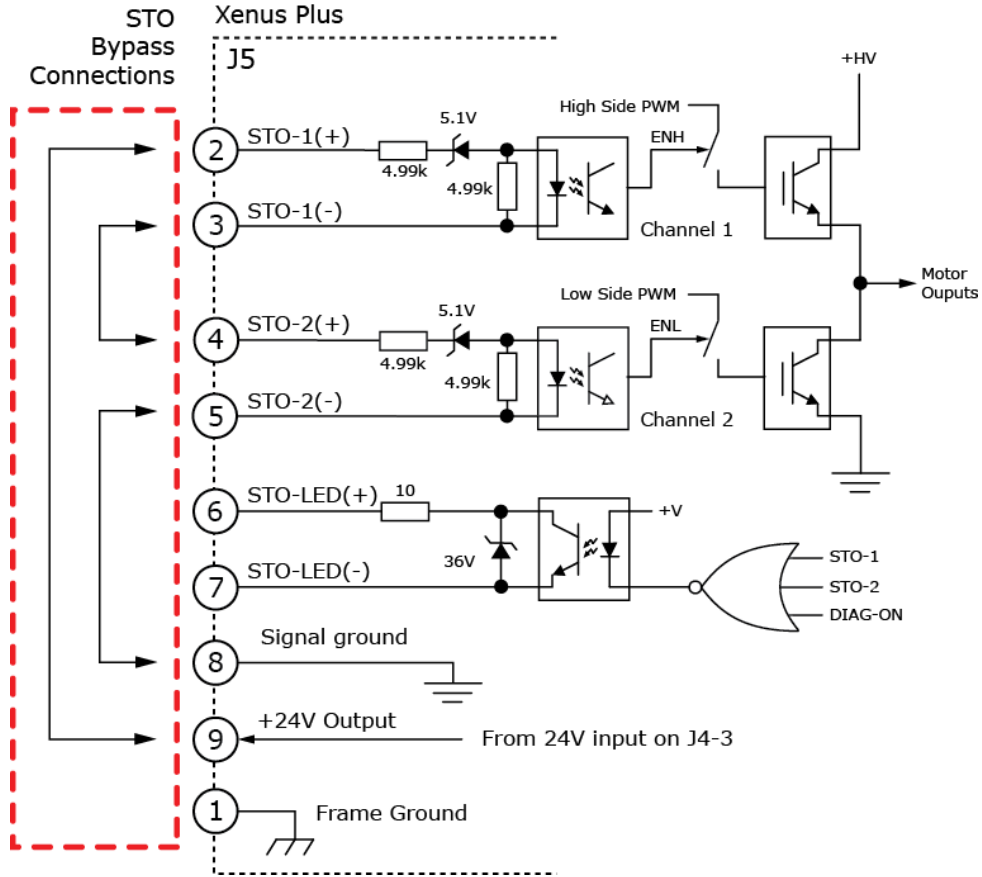

**4.7.2: XE2/XP2/XM2/800-1818/800-1819 (J6)**

The following information is for XE2, XP2, XM2 and 800-1819 drives only.

**Mating Connector**

Description	Manufacturer PN	Wire Size
Connector, D-Sub, 9-position, standard	AMP/Tyco: 205204-4	
AMPLIMITE HDP-20 Crimp-Snap contacts, 24-20AWG, sel AU/NI	AMP/Tyco: 66506-9	24-20AWG
Backshell, D-Sub, RoHS, metallized, for J6	Norcomp: 979-009-020R121	

**Pin Description**

Pin	Signal	Function
1	Frame Ground	Cable shield connection.
2	STO-1(+)	STO-1 Input
3	STO-1(-)	
4	STO-2(+)	STO-2 Input
5	STO-2(-)	
6	STO-1(+)	STO-1 Input. Pins 2 & 6 and pins 3 & 7 are connected together inside the drive. This second set of connection points is provided to simplify wiring of the STO bypass connections.
7	STO-1(-)	
8	STO-GND	24V ground
9	STO-24V	Internal power source for STO bypassing

 <b>DANGER</b>	<p><b>Refer to the Xenus Plus Dual-Axis STO User Manual</b></p>
	<p>The information provided in the Xenus Plus Dual-Axis STO User Manual must be considered for any application using the XE2/XP2/XM2 drive STO feature.</p> <p><b>Failure to heed this warning can cause equipment damage, injury, or death.</b></p>

**Safe Torque Off Bypass Wiring Diagram (XE2/XP2/XM2/800-1818/800-1819)**

The diagram below includes the STO bypass connections that will energize the two inputs (three opto-couplers). When this is done the STO feature is de-activated and control of the output PWM stage is delegated to the digital control core. If the STO feature is not being used, these connections must be made in order for the Xenus Plus to be enabled.

It is important to note that the XE2/XP2/XM2/800-1818/800-1819 and XEL/XPL/XML STO bypass connections are different. The diode shown in the muting/bypass plug should be used if XE2/XP2/XM2/800-1818/800-1819 and XEL/XPL/XML drives are used on the same equipment. Otherwise, the diode may be replaced by a jumper.

Bypass Plug Connections  
 Jumper pins:  
 2-4, 3-5, 6-8, 7-9 \*

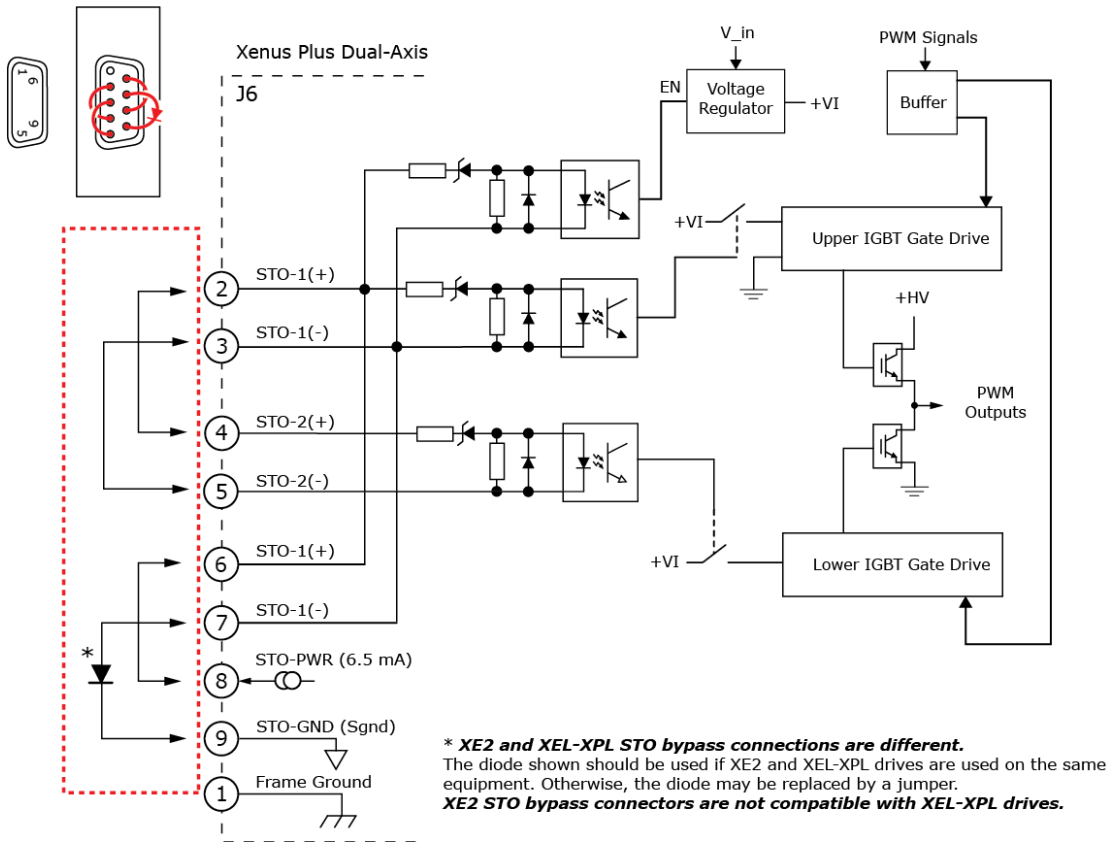

**\* XE2 and XEL-XPL STO bypass connections are different.**  
 The diode shown should be used if XE2 and XEL-XPL drives are used on the same equipment. Otherwise, the diode may be replaced by a jumper.  
**XE2 STO bypass connectors are not compatible with XEL-XPL drives.**

## 4.8: RS-232 Serial Communications

### Mating Connector

6-position, modular connector (RJ-11 style).

Copley Controls provides a prefabricated cable and modular-to-9-pin sub-D adapter in RS-232 Serial Cable Kit, PN SER-CK.

A diagram of the female connector is shown below.

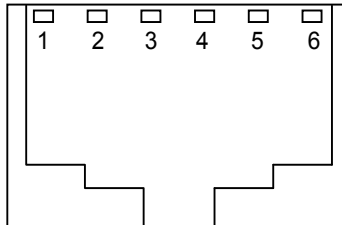

### Pin Description

Pin	Signal	Function
1	N/C	No connection
2	RxD	Receive data input from computer
3	Signal ground	Power supply ground
4	Signal ground	Power supply ground
5	TxD	Transmit data output to computer
6	N/C	No connection

### RS-232 Serial Communications Wiring Diagram

XEL, XPL, and XML drives use connector J6. XE2, XP2, XM2, 800-1818 and 800-1819 drives use connector J7.

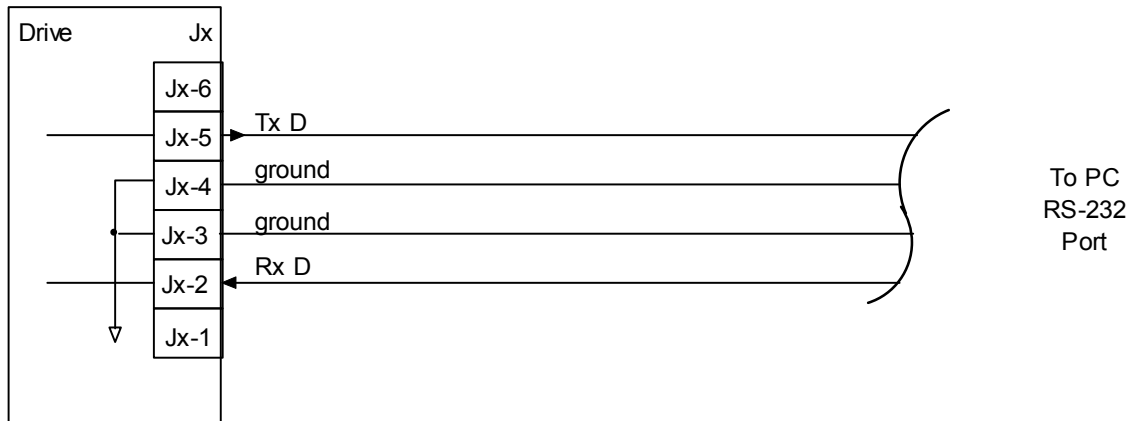

## 4.9: Network Ports

### 4.9.1: EtherCAT (XEL/XE2/800-1818/800-1819)

#### Mating Connector

Dual RJ-45 sockets accept standard Ethernet cables. The IN port connects to a master, or to the OUT port of a device that is 'upstream' between the Xenus Plus and the master. The OUT port connects to 'downstream' nodes. If Xenus Plus is the last node on a network, only the IN port is used. No terminator is required on the OUT port.

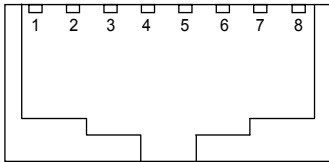

#### Pin Description\*

Pin	Signal	Function
1	TX+	Transmit data +
2	TX-	Transmit data -
3	RX+	Receive data +
4	-	
5	-	
6	RX-	Receive data -
7	-	
8	-	

\*Table applies to both EtherCAT connectors

#### EtherCAT Bus Wiring Diagram

The XEL drive uses connector J7. The XE2/800-1818/800-1819 drives use connector J8.

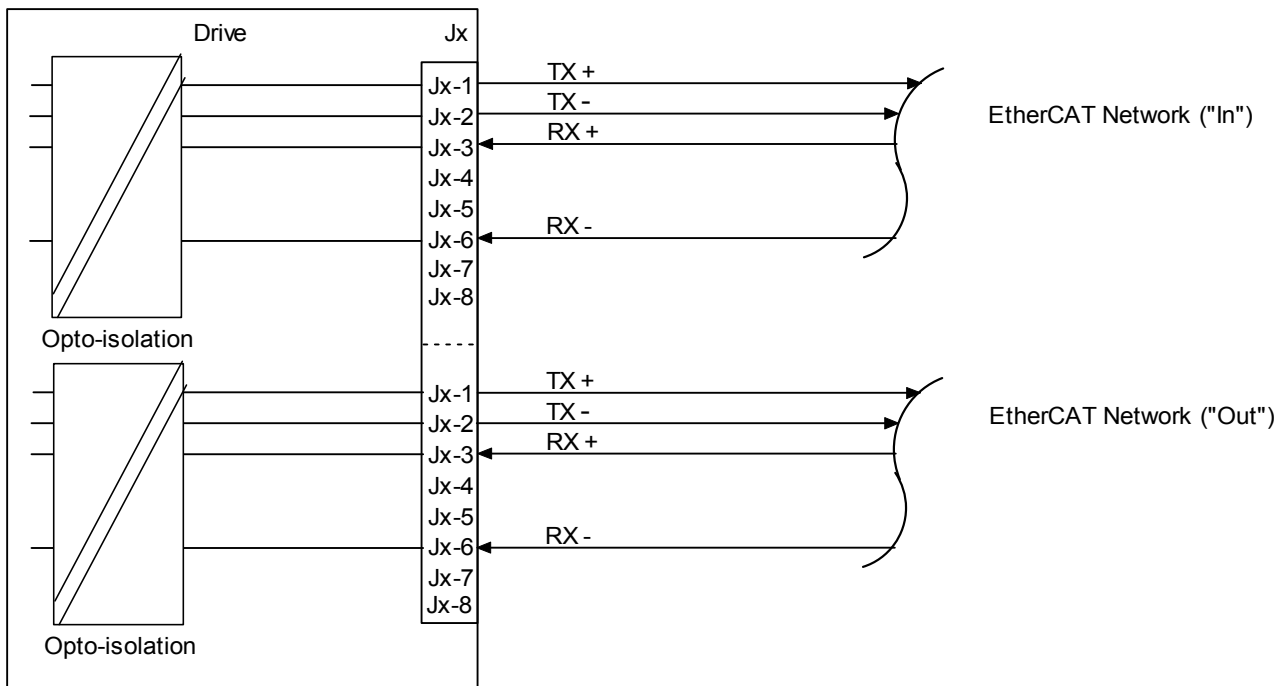



### 4.9.2: CAN Bus (XPL/XP2)

#### Mating Connector

8-position, modular connector (RJ-45 style). Copley Controls provides the following assemblies:

- Prefabricated 10 foot cable, PN XPL-NC-10
- Prefabricated 1 foot cable, PN XPL-NC-01
- Terminator Plug, PN XPL-NT

A diagram of the female connector is shown below.

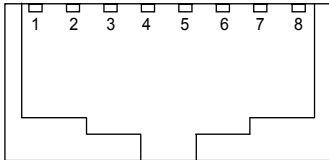

#### Pin Description\*

Pin	Signal	Function
1	CAN_H	CAN_H bus line (dominant high)
2	CAN_L	CAN_L bus line (dominant low)
3	CAN_Gnd	Ground / 0 V / V-
4	--	No connection
5	--	Pass through to second connector, no internal connection
6	CAN_SHLD	Pass through to second connector, no internal connection
7	CAN_Gnd	Ground / 0 V / V-
8	CAN V+	Pass through to second connector, no internal connection

\*Table applies to both CAN connectors

#### CAN Bus Wiring Diagram

The XPL drive uses connector J7. The XP2 drive uses connector J8.

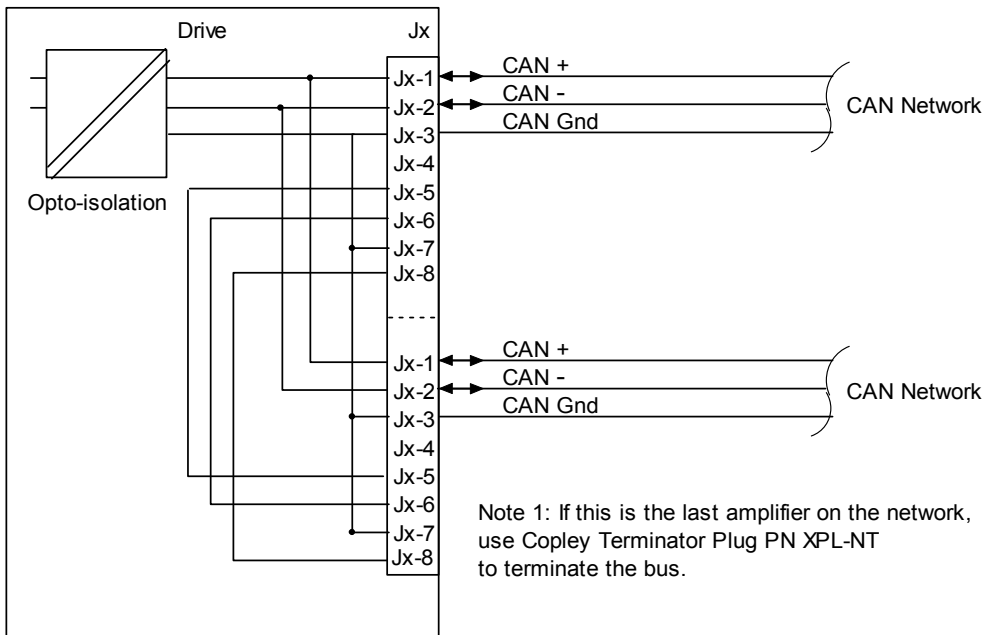

**4.9.3: MACRO Port (J7-XML/J8-XM2)**

The XML/XM2's duplex SC sockets, shown below, accept standard optical fiber.

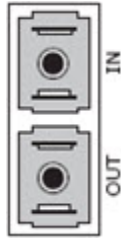

The IN port connects to a master or to the OUT port of a device that is “upstream,” between the XML/XM2 and the master. The OUT port connects to “downstream” nodes. If XML/XM2 is the last node on a network, only the IN port is used. No terminator is required on the OUT port.

## 4.10: Control I/O

### 4.10.1: Non-Isolated Control - XEL/XPL/XML (J8)

#### Mating Connectors

Description	Manufacturer PN	Wire Size
26 Position, 0.1 x 0.09 High Density D-Sub Female, Solder Style Connector	Norcomp 180-026-203L001	24 - 30 AWG
Back shell	Norcomp 979-015-020R121	
Solder style connector included in Connector Kits XEL-CK, XML-CK, and XPL-CK.		

Pin connections for the bulkhead connector on the drive are shown here:

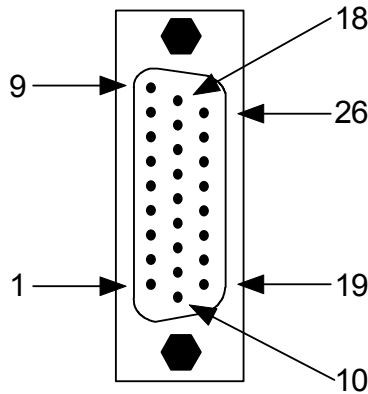

#### Pin Description

Pin	Signal	Function
1	Frame Ground	Cable shield connection.
2	Ref + (AIN1 +)	Analog command positive input—single analog.
3	Ref - (AIN1 -)	Analog command negative input—single analog.
4	IN1	Enable
5	IN2	Programmable input.
6	IN3	Mode-dependent. See <a href="#">Mode-Dependent Dedicated Inputs (p. 108)</a> .
7	IN4	
8	IN5	
9	AOUT	Programmable, 12-bit, $\pm 5$ Vdc.
10	IN6	Mode-dependent. See <a href="#">Mode-Dependent Dedicated Inputs (p. 108)</a> .
11	AIN2 +	Analog input 2 positive input.
12	AIN2 -	Analog input 2 negative input.
13	Multi-mode port /S2	Mode-dependent. See <a href="#">Mode-Dependent Dedicated Inputs (p. 108)</a> .
14	Multi-mode port S2	
15	Signal Ground	Signal ground reference for inputs and outputs.
16	OUT1	Programmable outputs.
17	OUT2	
18	OUT3 (HS)	
19	Signal Ground	Signal ground for +5Vdc, inputs and outputs.

Continued...

...Pin Description, continued:

20	+5 Vdc	+5 Vdc output. Total load current on J8-20, J10-6, and J10-17 not to exceed 400 mA.
21	Multi-Mode Port /X	Programmable differential input/output port. See Mode Dependent Dedicated Inputs (below).
22	Multi-Mode Port X	
23	Multi-Mode Port /B	
24	Multi-Mode Port B	
25	Multi-Mode Port /A	
26	Multi-Mode Port A	

**Mode-Dependent Dedicated Inputs**

These inputs are dedicated to specific functions, depending on operating mode.

Mode	Selected Command Source			Function
	Digital Input Single Ended	Digital Input Differential	Multi-Mode Port	
Current & Velocity PWM 50%	IN 5	IN3(+) & IN4(-)	A & /A	PWM Input
Current & Velocity PWM 100%	IN 5 IN 6	IN3(+) & IN4(-) IN5(+) & IN6(-)	A & /A B & /B	PWM Input Direction Input
Position Pulse & Direction	IN 5 IN 6	IN3(+) & IN4(-) IN5(+) & IN6(-)	A & /A B & /B	Pulse Input Direction Input
Position Up/Down	IN 5 IN 6	IN3(+) & IN4(-) IN5(+) & IN6(-)	A & /A B & /B	Count Up Count Down
Position Quadrature	IN 5 IN 6	IN3(+) & IN4(-) IN5(+) & IN6(-)	A & /A B & /B	Channel A Channel B

**Digital Inputs (IN1-IN6) Wiring Diagram**

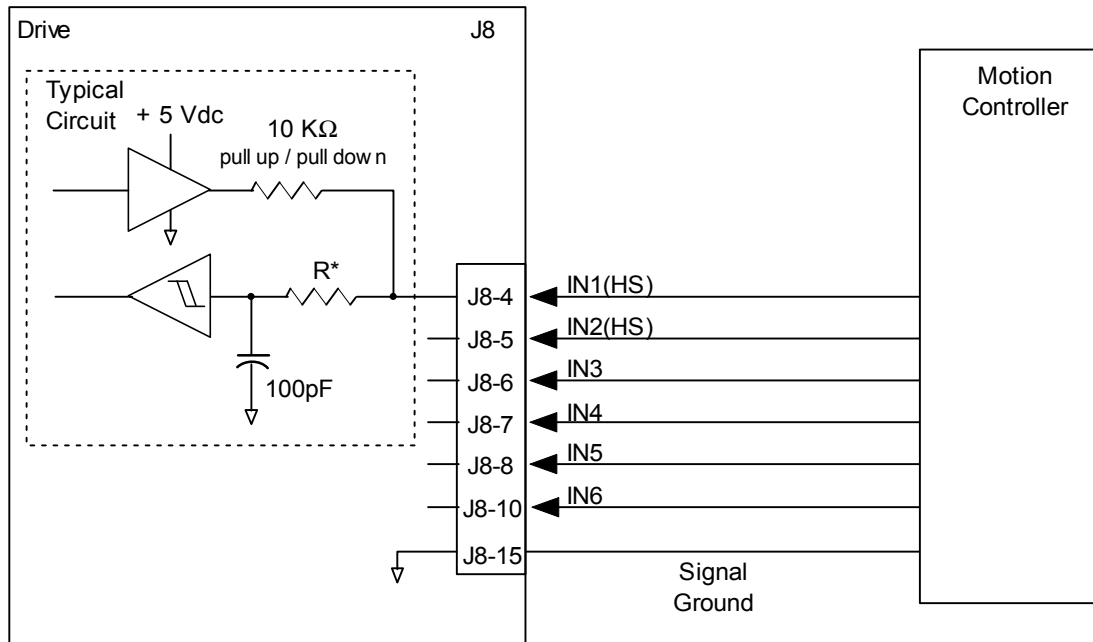

\*HS: IN1, IN2 R = 10 KΩ +24V MAX  
GP: IN3 - IN6 R = 1KΩ +12V MAX

**Digital Outputs Wiring Diagram**

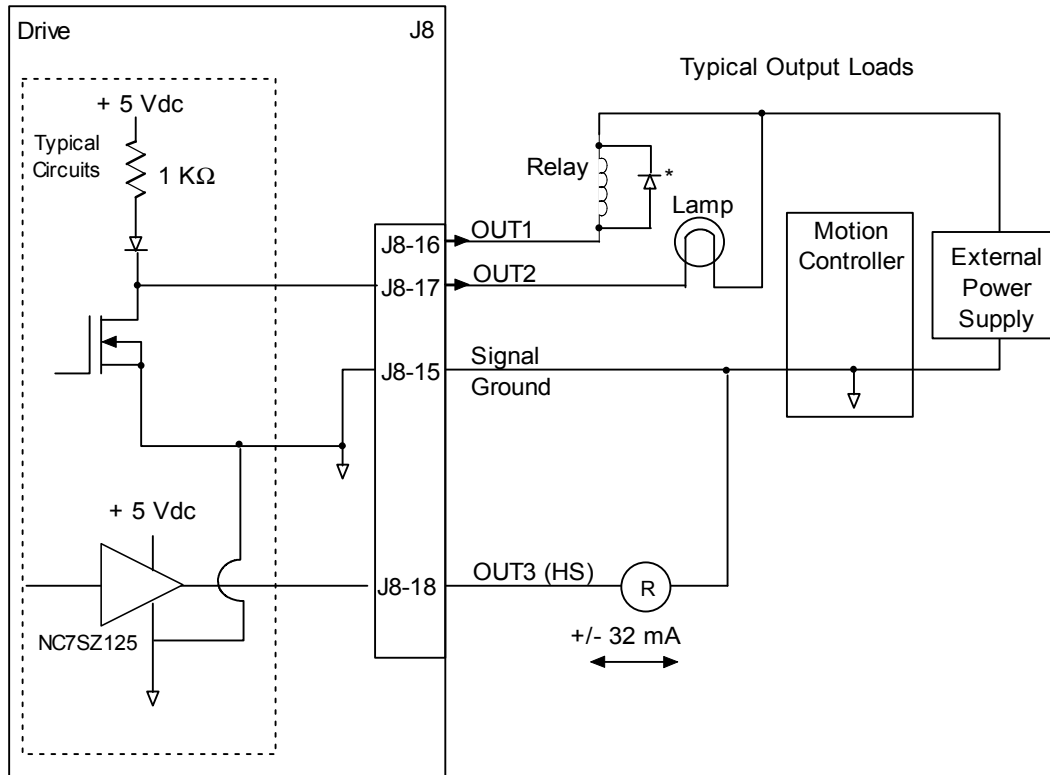

\* Flyback diode required for inductive loads

**Multi-Mode Port Interface Diagram**

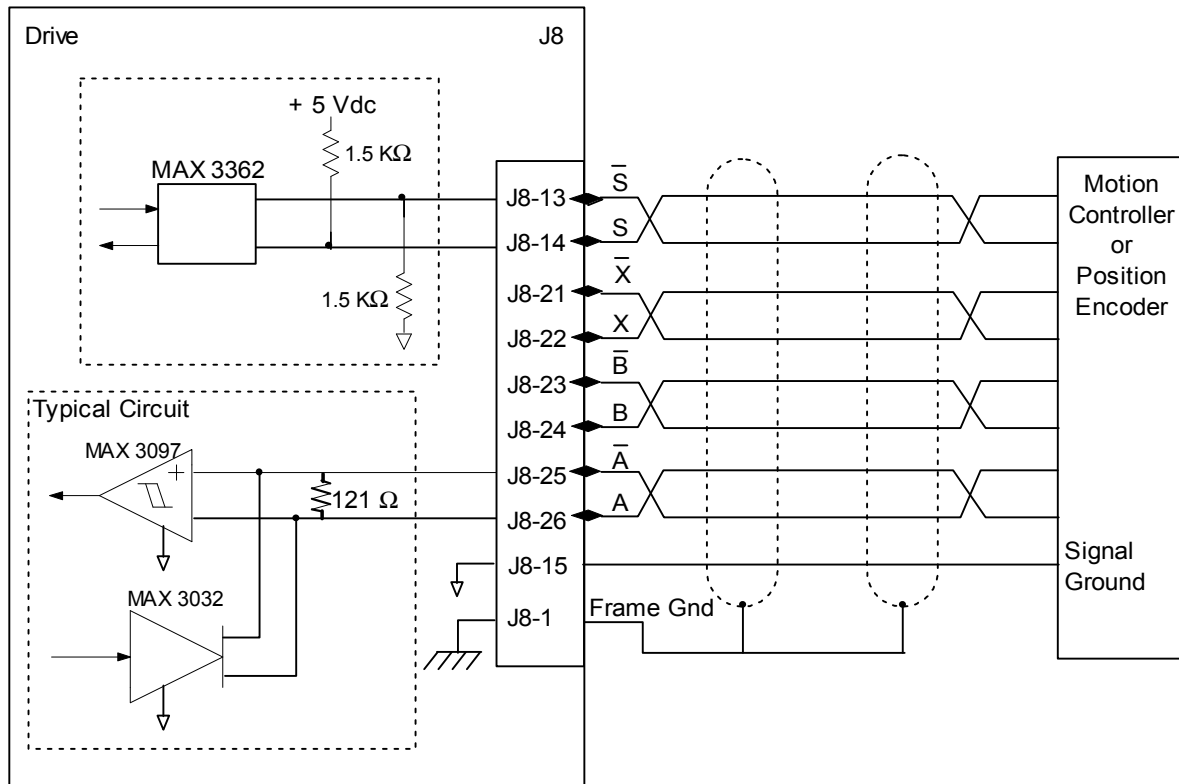

**Analog Input Wiring Diagram**

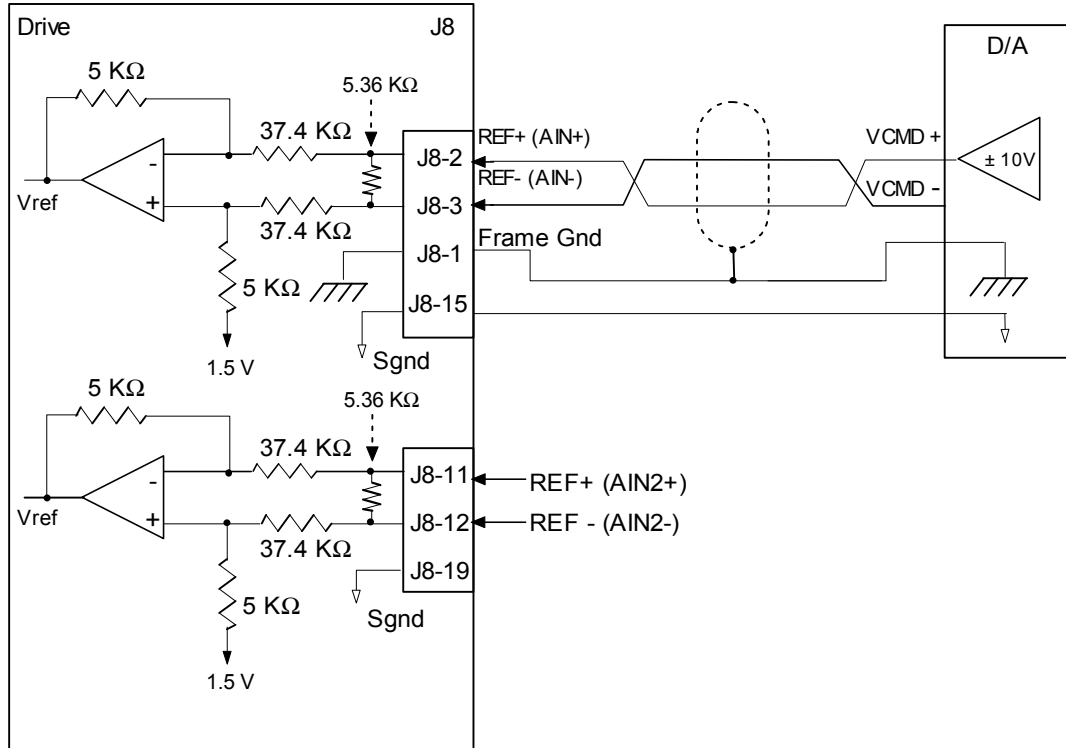

**Analog Output Wiring Diagram**

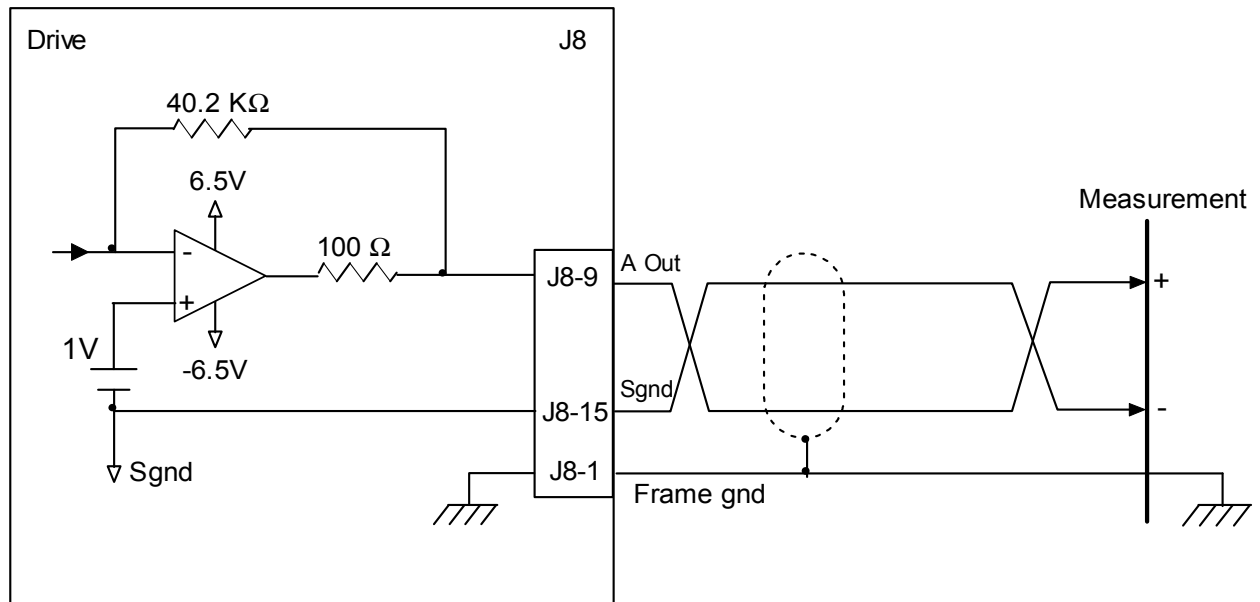

**4.10.2: Isolated Control - XEL/XPL/XML (J9)**

**Mating Connector**

Description	Manufacturer PN	Wire Size
15 Position, High-density, D-Sub, male, solder cup.	Norcomp: 180-015-103L001	24 - 30 AWG
Backshell	Norcomp: 979-009-020R121	
Solder style connector included in Connector Kits XEL-CK, XML-CK, and XPL-CK.		

Pin connections for the bulkhead connector on the drive are shown here:

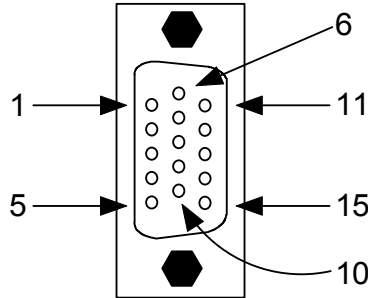

**J9 Pin Description**

Pin	Signal	Function
1	Frame Ground	Cable shield connection.
2	COMM_A	Common signal for first group of optically isolated programmable inputs.
3	IN7 GPI	Optically isolated programmable input.
4	IN8 GPI	
5	IN9 GPI	
6	IN10 GPI	
7	COMM_B	Common signal for second group of optically isolated programmable inputs.
8	IN11 GPI	Optically isolated programmable input.
9	IN12 GPI	
10	IN13 GPI	
11	IN14 GPI	
12	OUT5+ GPI	Optically isolated programmable output positive signal.
13	OUT5- GPI	Optically isolated programmable output negative signal.
14	OUT4+ GPI	Optically isolated programmable output positive signal.
15	OUT4- GPI	Optically isolated programmable output negative signal.

Optically Isolated Programmable Inputs Wiring Diagram

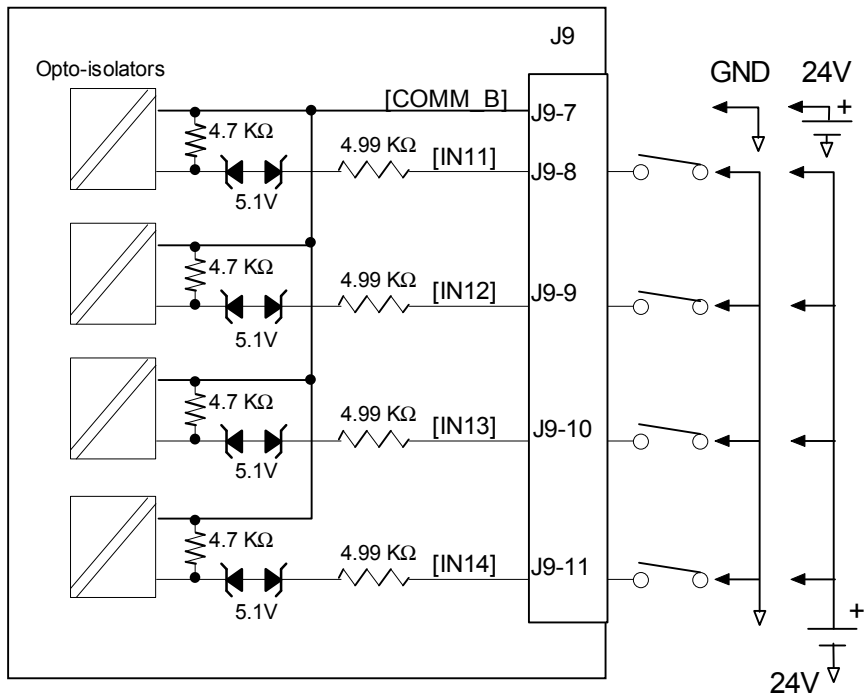
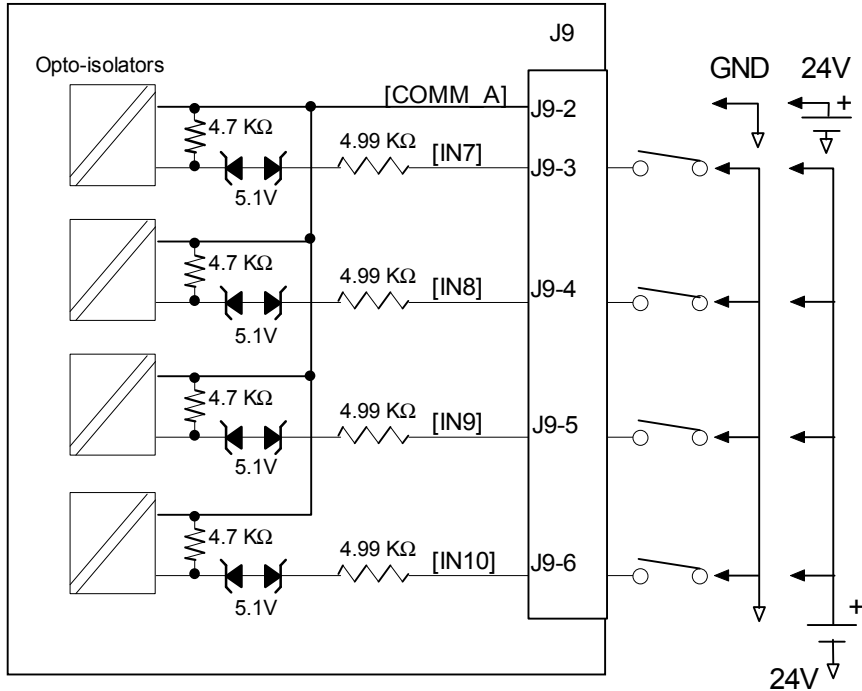



Optically Isolated Programmable Outputs Wiring Diagram

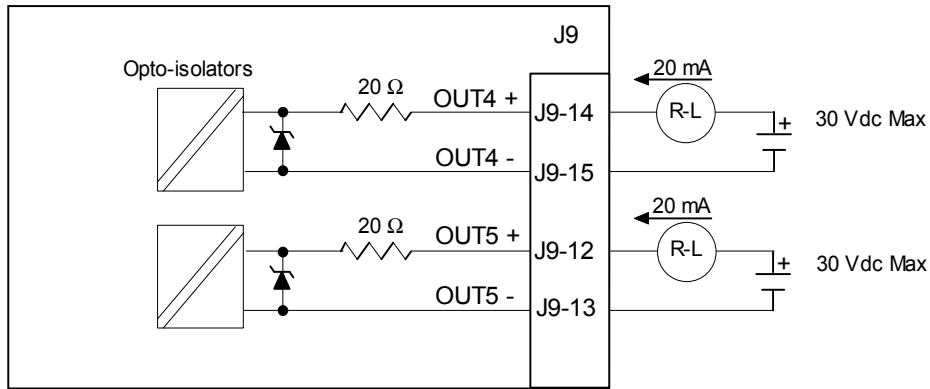

**4.10.3: Non-Isolated Control - XE2/XP2/XM2/800-1818/800-1819 (J12)**

**Mating Connections**

Description	Manufacturer PN	Wire Size
44 Position, 0.1 x 0.09 High Density D-Sub male, Solder Style Connector	Norcomp 180-044-103L001	24 - 30 AWG
Back shell	Norcomp 979-025-020R121	
Solder style connector included in Connector Kits XE2-CK, XP2-CK and XM2-CK.		

Pin connections for the bulkhead connector on the drive are shown here:

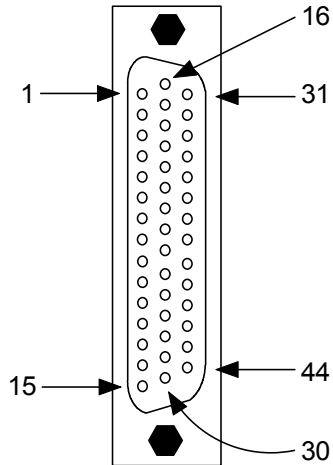

**Pin Description**

Pin	Signal	Function
1	Frame Ground	Cable shield connection.
2	AIN1 -	Analog command negative input--single analog.
3	AIN1+	Analog command positive input—single analog.
4	AIN2 -	Analog command negative input--single analog.
5	AIN2+	Analog command positive input—single analog.
6	Signal ground	Signal ground reference for inputs and outputs.
7	IN1	Enable.
8	IN2 Diff1(+)	Mode dependent dedicated input.
9	IN3 Diff1(-)	
10	IN4 Diff2(+)	
11	IN5 Diff2(-)	
12	IN11	Enable
13	IN12 Diff3(+)	Mode dependent dedicated input.
14	IN13 Diff3(-)	
15	IN14 Diff4(+)	
16	Signal ground	Signal ground reference for inputs and outputs.
17	A + 5Vdc Out3	
18	A-MultiEnc /S	Programmable differential input/output port..
19	A-MultiEnc /X	Programmable differential input/output port..

Continued...

...Pin Description, continued:

20	A-MultiEnc /B	Programmable differential input/output port.
21	A-MultiEnc /A	Programmable differential input/output port.
22	Signal ground	Signal ground reference for inputs and outputs.
23	B +5Vdc Out4	
24	B-MultiEnc /S	Programmable differential input/output port.
25	B-MultiEnc /X	
26	B-MultiEnc /B	
27	B-MultiEnc /A	
28	N/C	
29	N/C	
30	IN15 Diff4(-)	Mode dependent dedicated input.
31	Signal ground	Signal ground reference for inputs and outputs.
32	A +5Vdc Out3	
33	A-MultiEnc S	Programmable differential input/output port.
34	A-MultiEnc X	
35	A-MultiEnc B	
36	A-MultiEnc A	
37	Signal ground	Signal ground reference for inputs and outputs.
38	B +5Vdc Out4	
39	B-MultiEnc S	Programmable differential input/output port.
40	B-MultiEnc X	
41	B-MultiEnc B	
42	B-MultiEnc A	
43	N/C	
44	Signal ground	Signal ground reference for inputs and outputs.

**Mode Dependent Dedicated Inputs**

Axis A

These inputs are for Axis A and are dedicated to specific functions, depending on operating mode.

Mode	Selected Command Source			Function
	Digital Input Single Ended	Digital Input Differential	Multi-Mode Port	
Current & Velocity PWM 50%	IN 4	IN2(+) & IN3(-)	A & /A	PWM Input
Current & Velocity PWM 100%	IN 4 IN 5	IN2(+) & IN3(-) IN4(+) & IN5(-)	A & /A B & /B	PWM Input Direction Input
Position Pulse & Direction	IN 4 IN 5	IN2(+) & IN3(-) IN4(+) & IN5(-)	A & /A B & /B	Pulse Input Direction Input
Position Up/Down	IN 4 IN 5	IN2(+) & IN3(-) IN4(+) & IN5(-)	A & /A B & /B	Count Up Count Down
Position Quadrature	IN 4 IN 5	IN2(+) & IN3(-) IN4(+) & IN5(-)	A & /A B & /B	Channel A Channel B

Axis B

These inputs are for Axis B and are dedicated to specific functions, depending on operating mode.

Mode	Selected Command Source			Function
	Digital Input Single Ended	Digital Input Differential	Multi-Mode Port	
Current & Velocity PWM 50%	IN 14	IN12(+) & IN13(-)	A & /A	PWM Input
Current & Velocity PWM 100%	IN 14 IN 15	IN12(+) & IN13(-) IN14(+) & IN15(-)	A & /A B & /B	PWM Input Direction Input
Position Pulse & Direction	IN 14 IN 15	IN12(+) & IN13(-) IN14(+) & IN15(-)	A & /A B & /B	Pulse Input Direction Input
Position Up/Down	IN 14 IN 15	IN12(+) & IN13(-) IN14(+) & IN15(-)	A & /A B & /B	Count Up Count Down
Position Quadrature	IN 14 IN 15	IN12(+) & IN13(-) IN14(+) & IN15(-)	A & /A B & /B	Channel A Channel B

Digital Inputs (IN1~IN5, IN11~IN15) Wiring Diagram

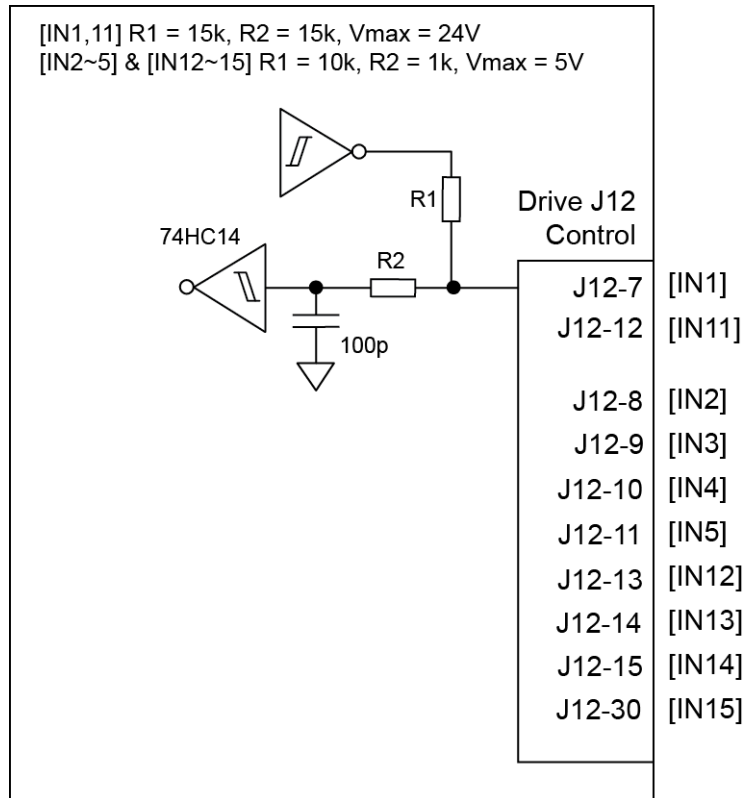

Analog Input Wiring Diagram

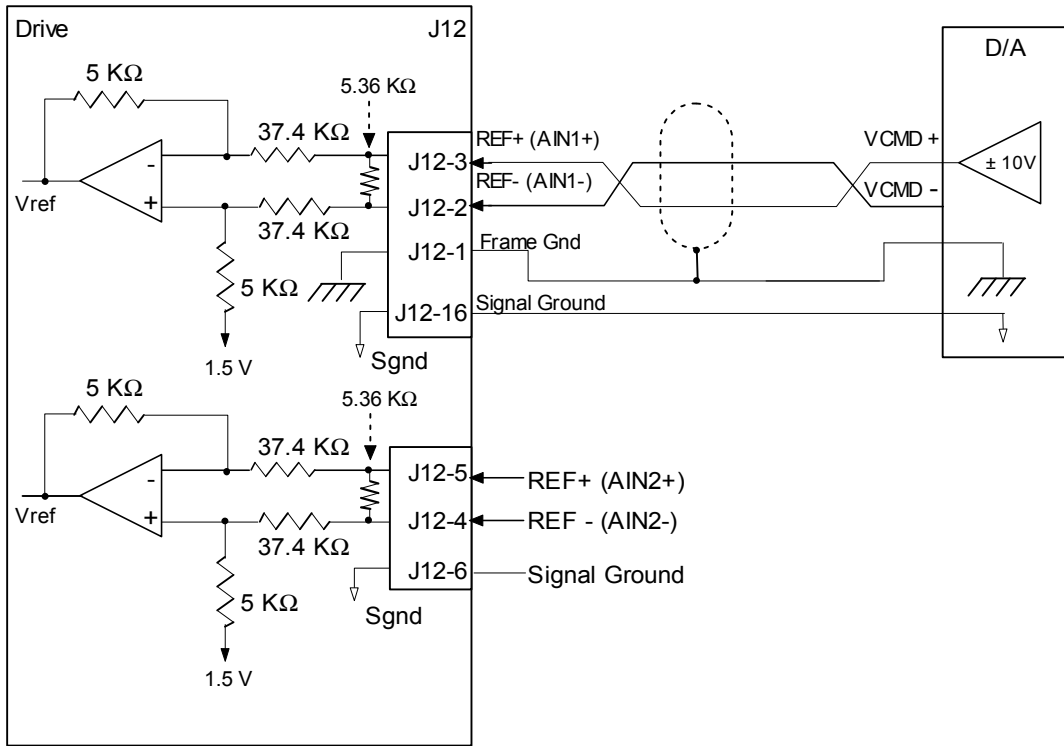

Multi-Mode Port Interface Diagram

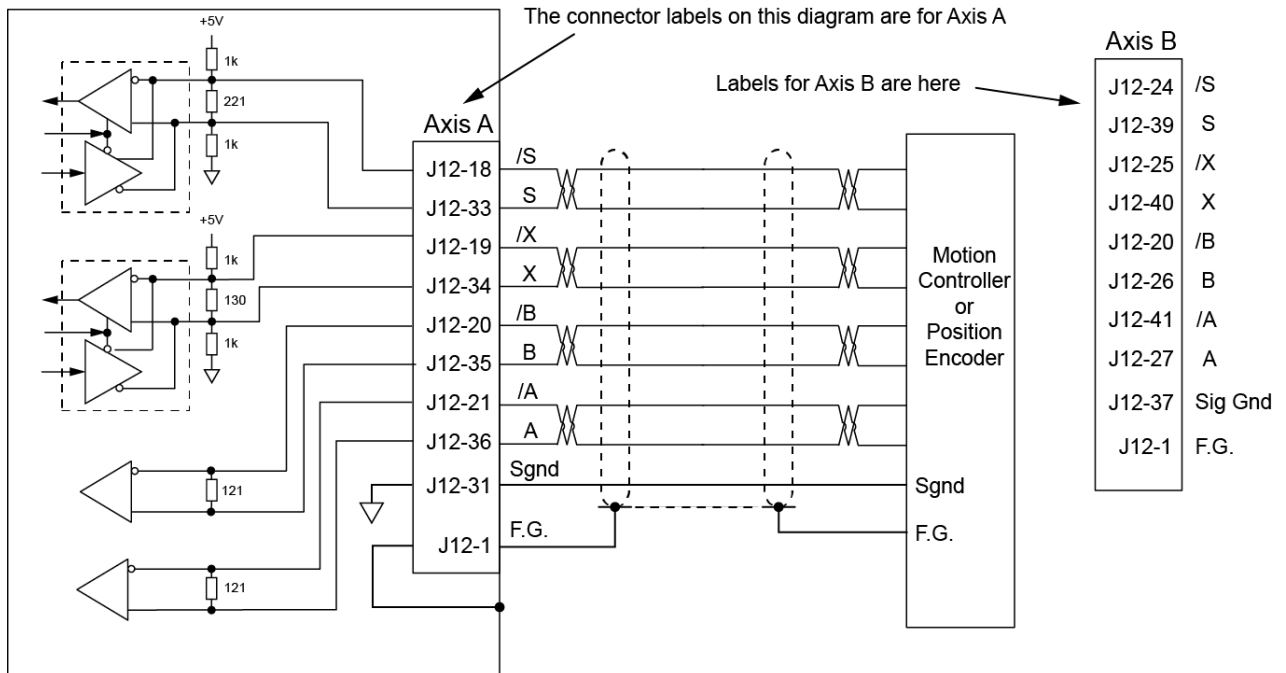

**4.10.4: Isolated Control - XE2/XP2/XM2/800-1818 (J9)**

J9 is a 26 position male D-sub connector used for isolated controls

**Mating Connections**

Description	Manufacturer PN	Wire Size
26 Position, High-Density D-Sub Female Solder Style Connector	Norcomp 180-026-203L001	24 - 30 AWG
Back shell	Norcomp 979-015-020R121	
Solder style connector included in Connector Kits XE2-CK, XP2-CK and XM2-CK.		

Pin connections for the bulkhead connector on the drive are shown here:

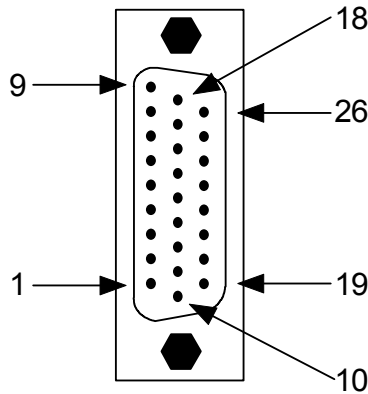

**XE2/XP2/XM2 Pin Description**

Pin	Signal	Function
1	Frame Ground	Cable shield connection.
2	IN6 GPI	Optically isolated programmable input.
3	IN7 GPI	
4	IN8 GPI	
5	IN9 GPI	
6	COM1	Common signal for first group of optically isolated programmable inputs (IN6-IN9)
7	IN16 GPI	Optically isolated programmable input.
8	IN17 GPI	
9	IN18 GPI	
10	OUT1- GPI	Optically isolated programmable output negative signal.
11	OUT2- GPI	
12	OUT3- GPI	
13	OUT4- GPI	
14	OUT5- GPI	
15	N/C	No connection.
16	N/C	No connection.
17	COM2	Common signal for first group of optically isolated programmable inputs (IN16-IN19)
18	IN19 GPI	Optically isolated programmable input.
19	OUT1+ GPI	Optically isolated programmable output positive signal.
20	OUT2+ GPI	Optically isolated programmable output positive signal.

Continued...

...Pin Description, continued:

21	OUT3+ GPI	Optically isolated programmable output positive signal.
22	OUT4+ GPI	
23	OUT5+ GPI	
24	N/C	No connection.
25	N/C	
26	N/C	

**800-1819 Pin Description**

Pin	Signal	Function
1	Frame Ground	Cable shield connection.
2	IN6 GPI	Optically isolated programmable input.
3	IN7 GPI	
4	IN8 GPI	
5	IN9 GPI	
6	COM1	Common signal for first group of optically isolated programmable inputs (IN6-IN9)
7	IN16 GPI	Optically isolated programmable input.
8	IN17 GPI	
9	IN18 GPI	
10	OUT1- GPI	Optically isolated programmable output negative signal.
11	OUT2- GPI	
12	OUT3- GPI	
13	S1_A	S1_A~S4_A signals are outputs driven by 453 ohm resistors that connect to an internal voltage source +6VISO. These provide limited current to drive the input diode anodes of optical limit switches on the motor.
14	S2_A	
15	S3_A	
16	S4_A	
17	N/C	No connection
18	IN19 GPI	Optically isolated programmable input.
19	OUT1+ GPI	Optically isolated programmable output positive signal.
20	OUT2+ GPI	
21	OUT3+ GPI	
22	S1_RTN	S1_RTN~S4_RTN connect to the input diode cathodes of the optical limit switches on the motor.
23	S2_RTN	
24	S3_RTN	
25	S4_RTN	
26	N/C	No connection.

Optically Isolated Programmable Inputs Wiring Diagram, XE2/XP2/XM2/800-1818

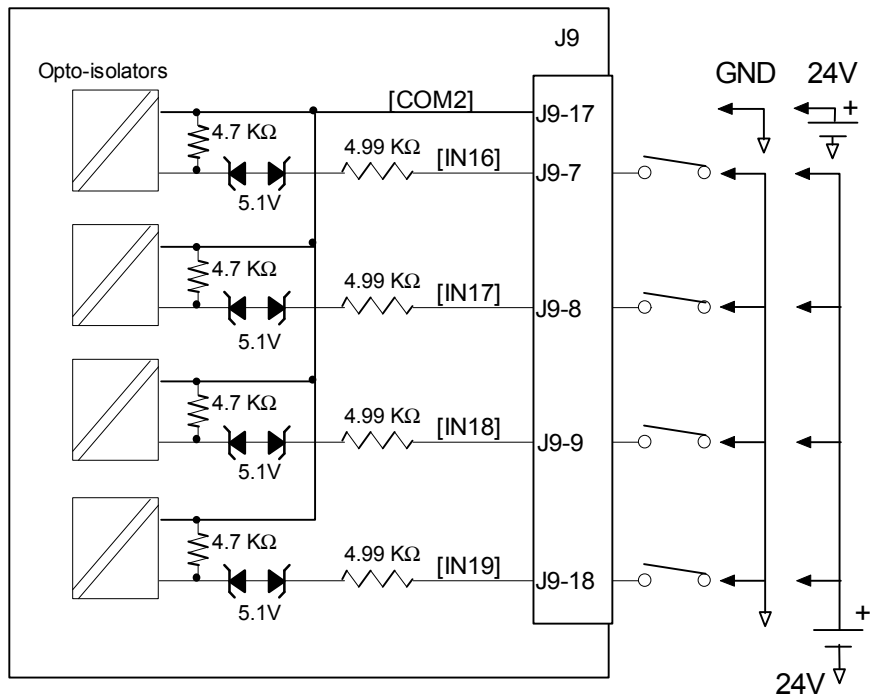
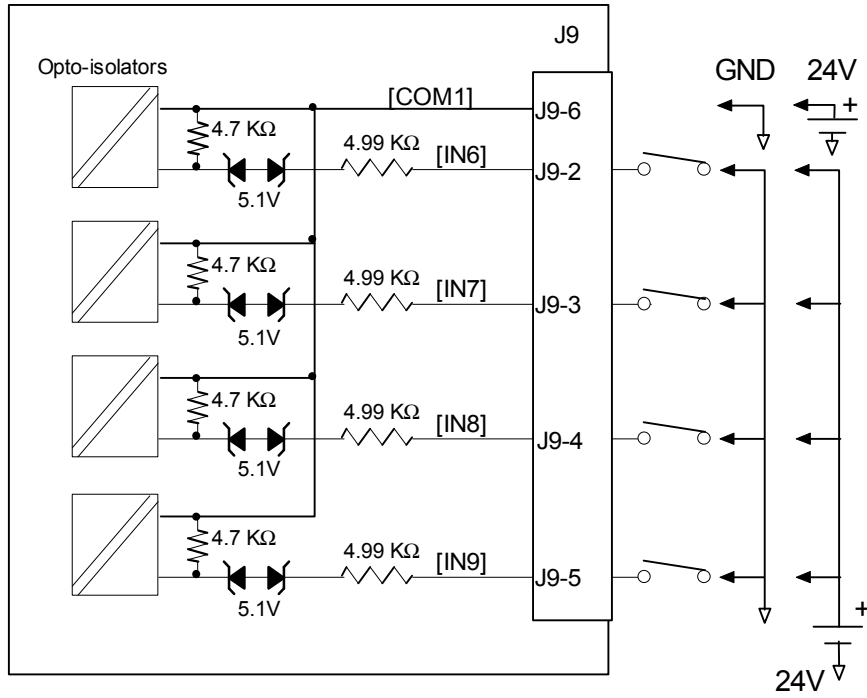



Optically Isolated Programmable Inputs Wiring Diagram, 800-1819

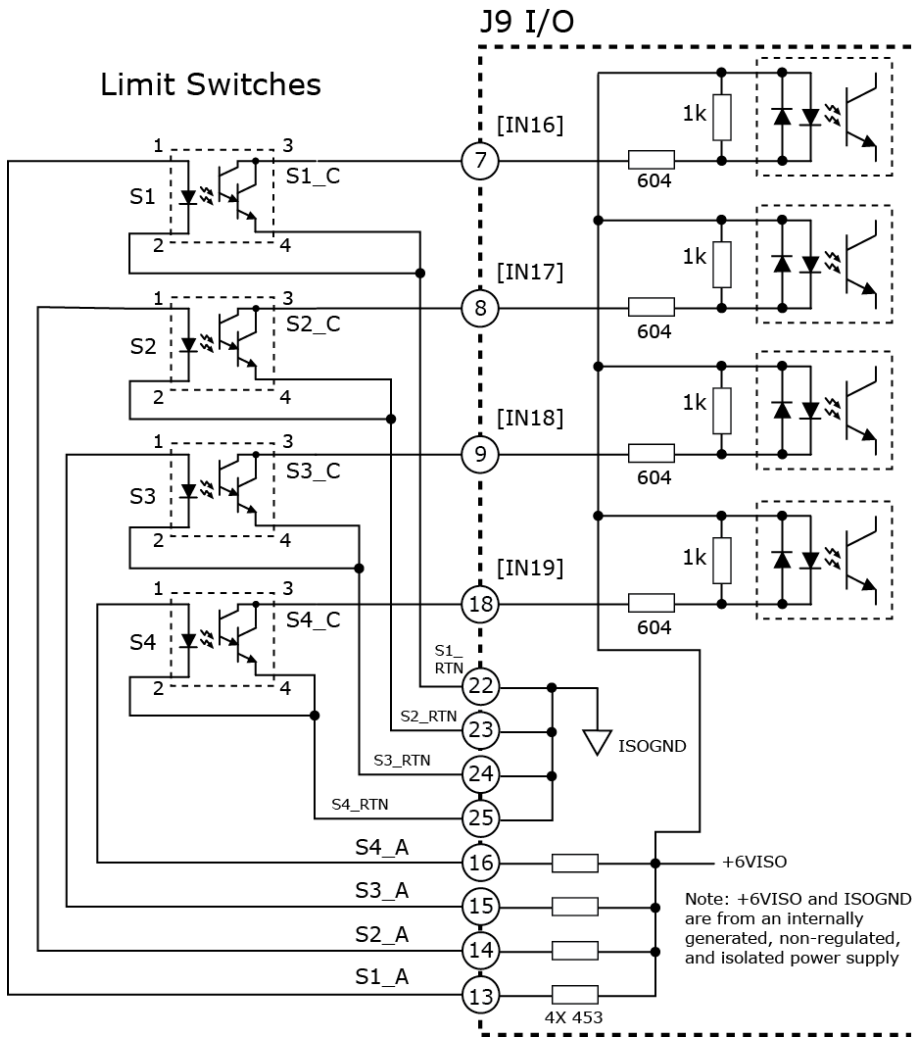

Note: Wiring diagram for IN6 – IN9 on the 800-1819 is the same as for the XE2/XP2/XM2/800-1818.

Optically Isolated Programmable Outputs Wiring Diagram, XE2/XP2/XM2/800-1818/800-1819

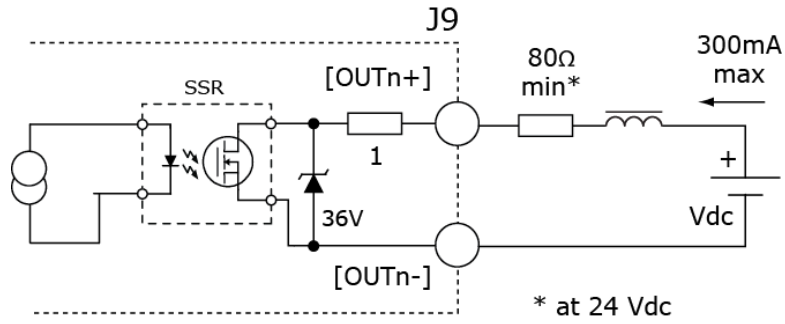

J9 Wiring

Signal	Pins	Signal	Pins
[OUT1+]	19	[OUT1-]	10
[OUT2+]	20	[OUT2-]	11
[OUT3+]	21	[OUT3-]	12
[OUT4+]	22	[OUT4-]	13
[OUT5+]	23	[OUT5-]	14

Note: Model 800-1819 does not have OUT4 and OUT5.

## 4.11: Motor Feedback

The following motor feedback information is true for single and dual axis drives with the exception of the motor over-temperature input. In the Xenus Plus Single Axis models the motor over-temperature input is an analog input whereas it is a digital input in the Xenus Plus Dual Axis models. The Xenus Plus Single Axis drive has one feedback connector, J10. The Xenus Plus Dual Axis drive has two feedback connectors, J10 and J11. All feedback connectors have identical wiring specifications, with the exception of the 800-1819.

### Mating Cable Connector

Description	Manufacturer PN	Wire Size
26 Position, High-Density D-Sub Male Solder Style Connector	Norcomp: 180-026-103L001	24 - 30 AWG
Back shell	Norcomp: 979-015-020R121	
Solder style connector included in Connector Kits XEL-CK, XE2-CK, XPL-CK, XP2-CK, XML-CK, and XM2-CK.		

Pin connections for the bulkhead connector on the drive are shown here:

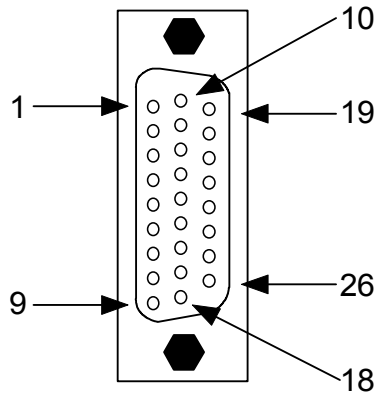

**Pin Description Quad A/B Incremental Encoder**

Pin	Signal	Function
1	Frame Ground	Cable shield connection.
2	Digital Hall U	
3	Digital Hall V	
4	Digital Hall W	
5	Signal Ground	Signal and +5 Vdc ground.
6	+5 Vdc	Encoder and/or Halls +5 Vdc power supply output.
7	Motemp	Motor over temperature switch. May be programmed to other functions. Analog input on the XEL/XPL/XML models. Digital input on the XE2/XP2/XM2/800-1818 models.
8	Encoder /X1 Input	Primary incremental encoder inputs.
9	Encoder X1 Input	
10	Encoder /B1 Input	
11	Encoder B1 Input	
12	Encoder /A1 Input	
13	Encoder A1 Input	
14	Encoder /S1 Input	
15	Encoder S1 Input	
16	Signal Ground	Signal and +5 Vdc ground.
17	+5 Vdc	Encoder and/or Halls +5 Vdc power supply output.
18	Sin1(-)	Analog Sin/Cos/Index encoder signals.
19	Sin1(+)	
20	Cos1(-)	
21	Cos1(+)	
22	Index1(-)	
23	Index1(+)	
24	IN15 (XEL/XPL/XML) IN21/IN22 (XE2/XP2)	General purpose input (IN21 is on J10, IN22 is on J11)
25	Signal Ground	Signal and +5 Vdc ground.
26	Signal Ground	Signal and +5 Vdc ground.

**Pin Description Resolver Xenus Plus (-R)**

Pin	Signal	Function
1	Frame Ground	Cable shield connection.
2	Digital Hall U	
3	Digital Hall V	
4	Digital Hall W	
5	Signal Ground	Signal and +5 Vdc ground.
6	+5 Vdc	Encoder and/or Halls +5 Vdc power supply output.
7	Motemp	Motor over temperature switch. May be programmed to other functions. Analog input on the XEL/XPL/XML models. Digital input on the XE2/XP2 models.
16	Signal Ground	Signal and +5 Vdc ground.
17	+5 Vdc	Encoder and/or Halls +5 Vdc power supply output.
18	S1 Sin(-)	Resolver Sin inputs.
19	S3 Sin(+)	
20	S4 Cos(-)	Resolver Cos inputs.
21	S2 Cos(+)	
22	R2 Ref(-)	Resolver Ref inputs.
23	R1 Ref(+)	
24	IN15 (XEL/XPL/XML) IN21/IN22 (XE2/XP2)	General purpose input (IN21 is on J10, IN22 is on J11)
25	Signal Ground	Signal and +5 Vdc ground.
26	Signal Ground	Signal and +5 Vdc ground.

**Pin Description 800-1819**

Pin	Signal	Function
1	Frame Ground	Cable shield connection.
2	N/C	No connection
3	N/C	
4	N/C	
5	Signal Ground	Signal and +5 Vdc ground.
6	N/C	No connection
7	Motemp	Motor over temperature switch. May be programmed to other functions. Digital input.
8	N/C	No connection
9	Resolver Abs A	Type 2 motor only
10	Resolver Abs B	
11	Resolver Abs C	
12	N/C	No connection
13	N/C	
14	N/C	
15	N/C	
16	Signal Ground	Signal and +5 Vdc ground.
17	+5 Vdc	Encoder +5 Vdc power supply output.
18	Resolver Inc A	Type 2 & Type 1 motors

Pin	Signal	Function
19	Resolver Inc B	No connection
20	Resolver Inc C	
21	N/C	
22	N/C	
23	Resolver Ref(+)	Resolver Ref inputs.
24	N/C	No connection
25	Signal ground	Signal and +5 Vdc ground.
26	Signal ground	Signal and +5 Vdc ground.

**Quad A/B Incremental Encoder Wiring Diagram**

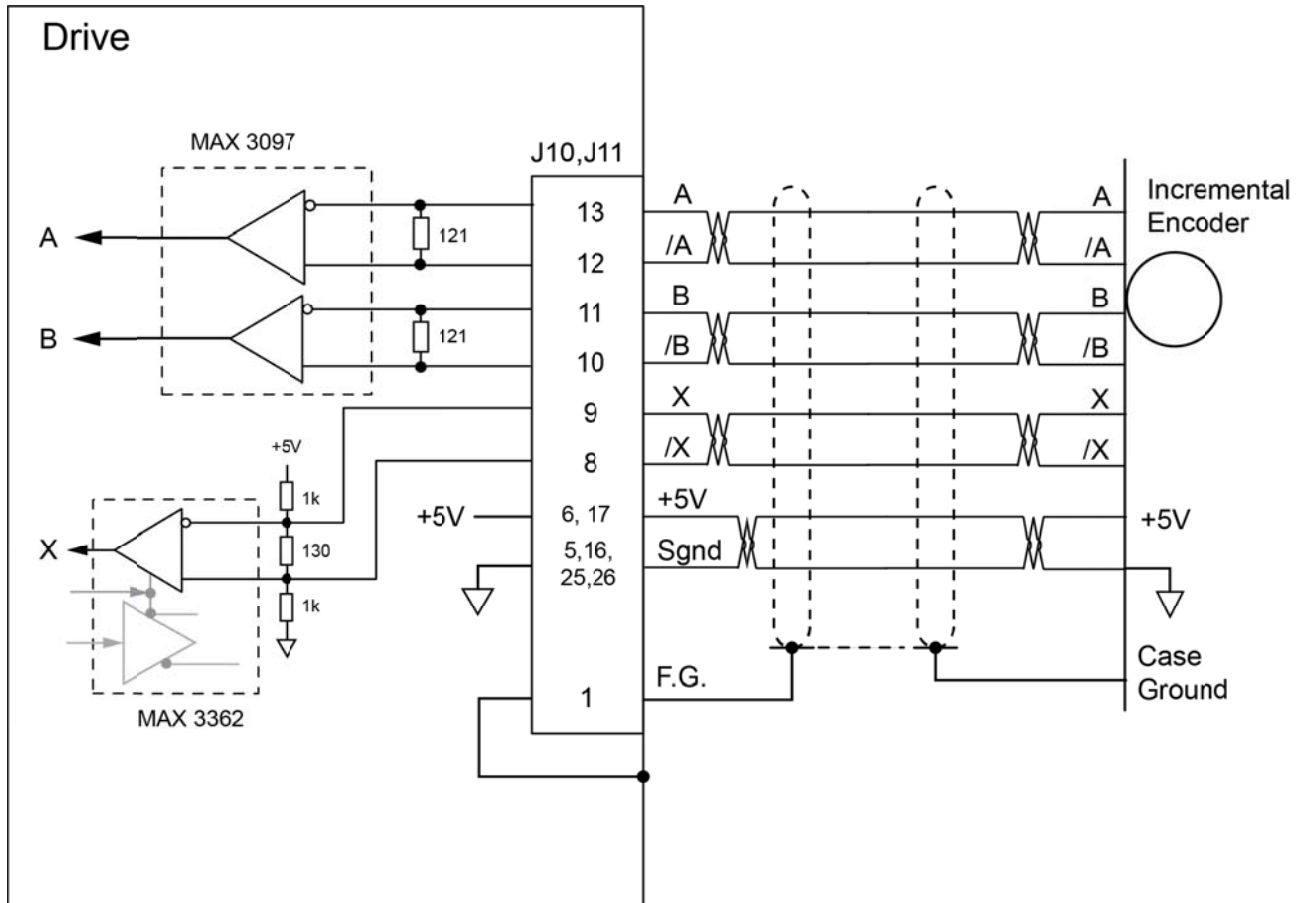

In XEL/XPL/XML there are two encoder +5V outputs at 400 mA each, and in the XE2/XP2/XM2/800-1818 there are 4 encoder +5V outputs at 500 mA each.

Hall Switch Wiring Diagram

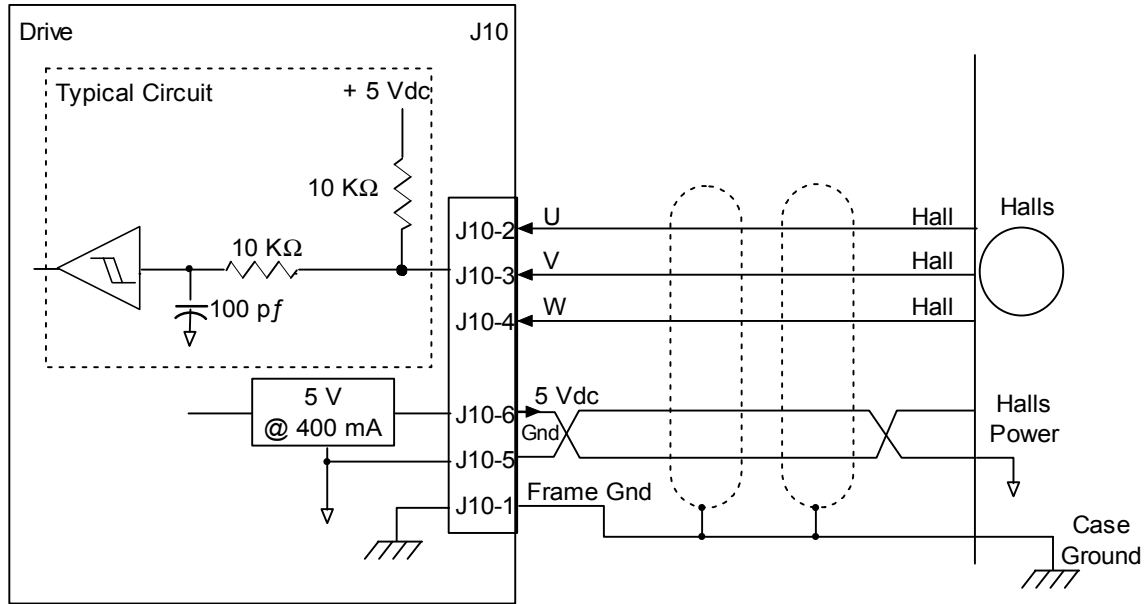

In XEL/XPL/XML there are two encoder +5V outputs at 400 mA each, and in the XE2/XP2/XM2/800-1818 there are 4 encoder +5V outputs at 500 mA each.

Analog Sin/Cos Encoder Wiring Diagram

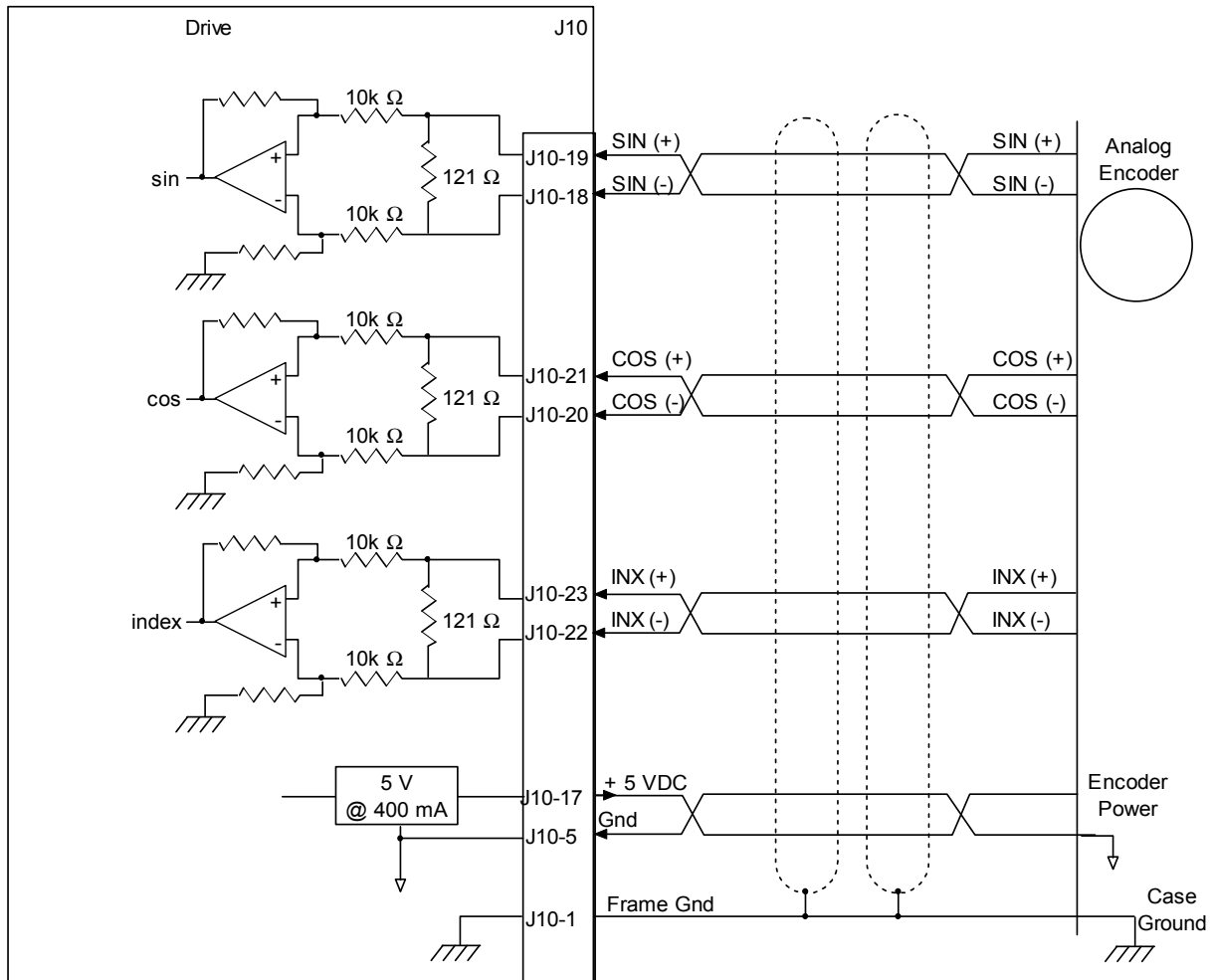

In XEL/XPL/XML there are two encoder +5V outputs at 400 mA each, and in the XE2/XP2/XM2/800-1818 there are 4 encoder +5V outputs at 500 mA each.



**Resolver Wiring Diagram**

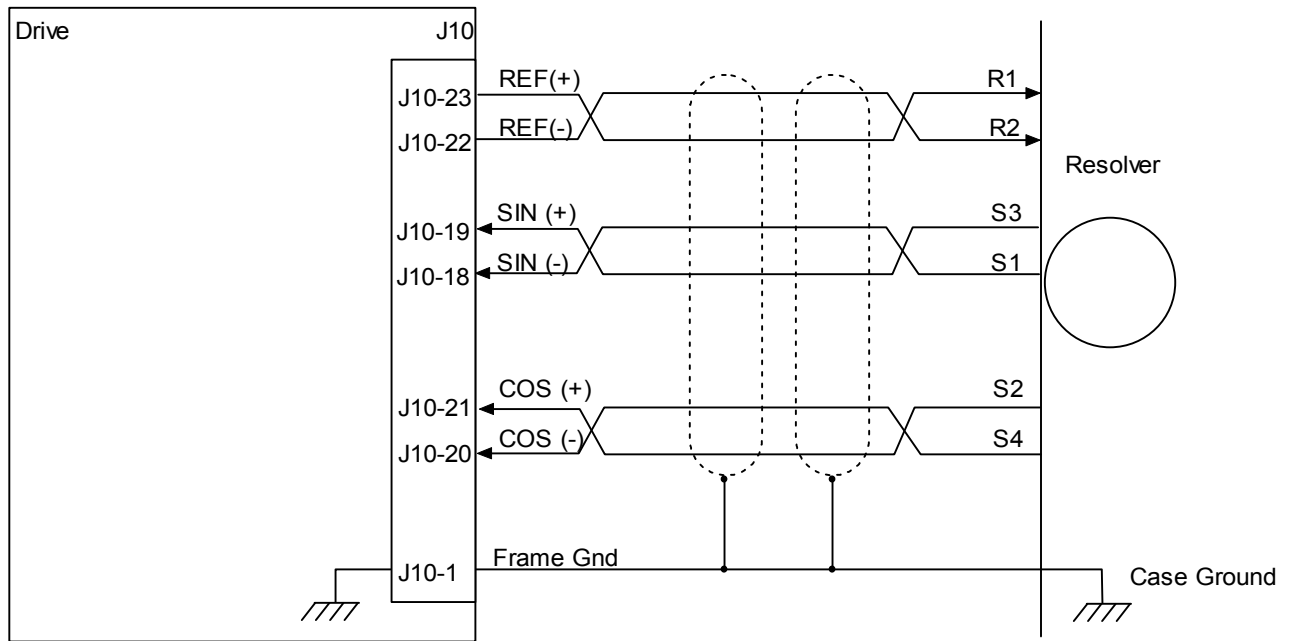

**Resolver Wiring Diagram, 800-1819**

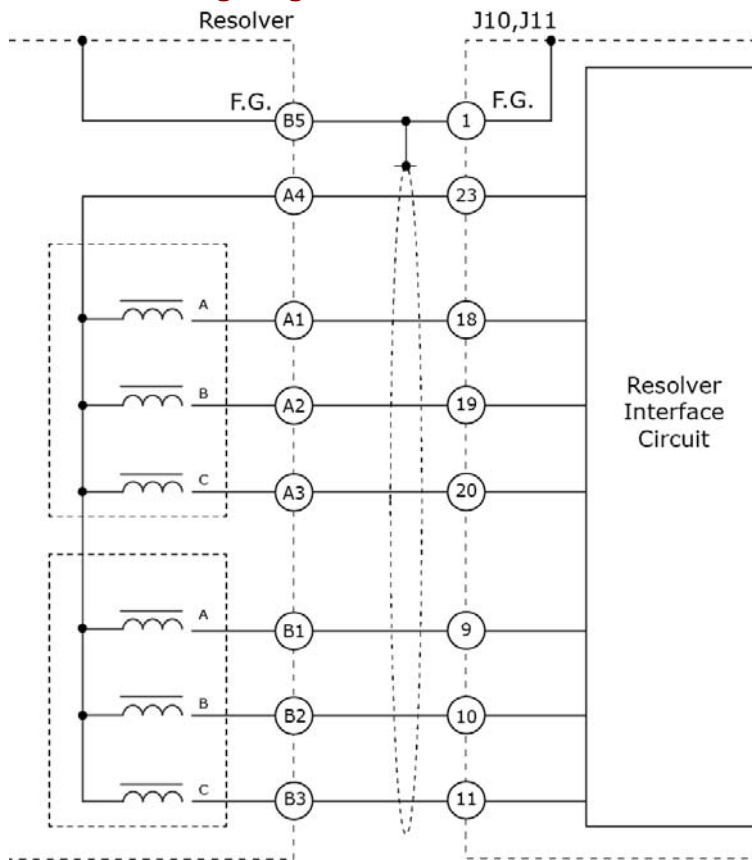

**Motor Over Temperature Wiring Diagram: XEL/XPL/XML**

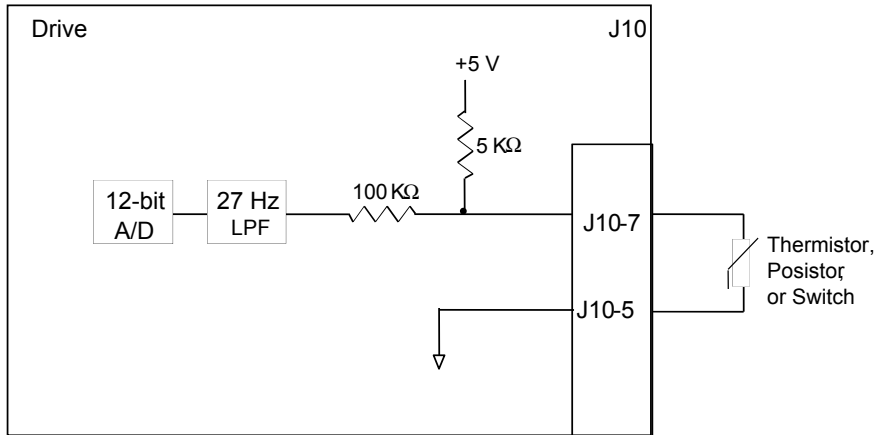

**Motor Over Temperature Wiring Diagram: XE2/XP2/XM2/800-1818/800-1819**

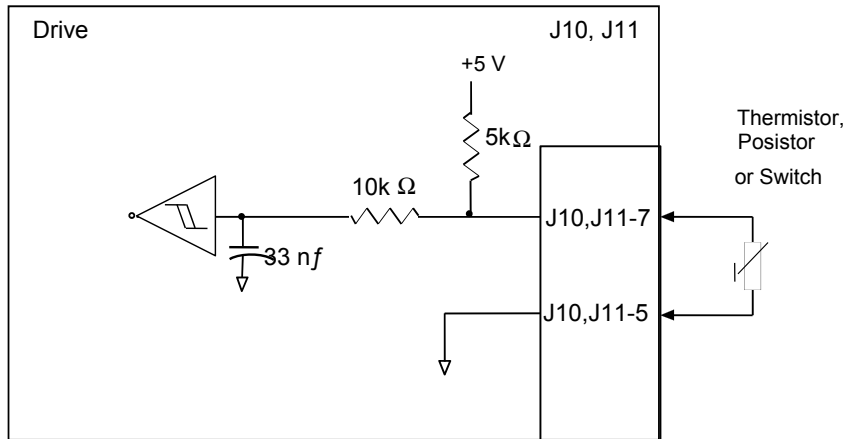

**General Purpose Input Wiring Diagram: XEL/XPL/XML**

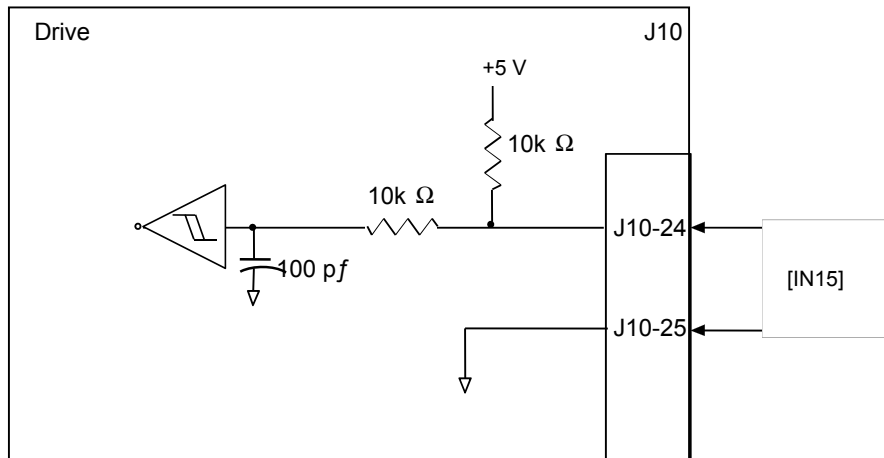

General Purpose Input Wiring Diagram: XE2/XP2/XM2/800-1818/800-1819

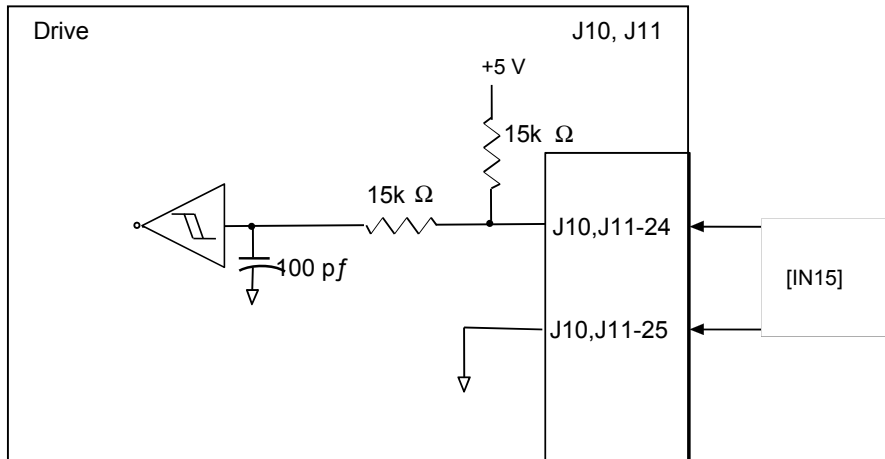

# APPENDIX

## A: REGEN RESISTOR SIZING AND CONFIGURATION

This chapter describes the steps used to determine if a regen resistor is required and what the optimal resistor characteristics would be for a given application. For an overview of regeneration and regen resistors, see [Regen Resistor Theory \(p. 61\)](#). To configure a custom regen resistor, see the *CME 2 User Guide*. Additional information about regeneration can be found in this document on the web-site: [http://www.copleycontrols.com/Motion/pdf/Xenus\\_regen\\_guide-03-04.pdf](http://www.copleycontrols.com/Motion/pdf/Xenus_regen_guide-03-04.pdf)

The contents of this chapter include:

A.1: Sizing a Regen Resistor..... 133

## A.1: Sizing a Regen Resistor

### A.1.1: Gather Required Information

Calculating the power and resistance of the regen resistor requires information about the drive and the rotary or linear motor application.

For all applications, gather the following information:

- 1 Details of the complete motion profile, including times and velocities
- 2 Drive model number
- 3 Applied line voltage to the drive
- 4 Torque constant of the motor
- 5 Resistance (line-to-line) of the motor windings.

For rotary motor applications, gather this additional information:

- 1 Load inertia seen by the motor
- 2 Inertia of the motor.

For linear motor applications, gather this additional information:

- 1 Mass of the moving load
- 2 Mass of the motor forcer block if the motor rod is stationary  
OR  
Mass of the motor rod if the motor forcer block is stationary.

### A.1.2: Observe the Properties of Each Deceleration During a Complete Cycle of Operation

For each deceleration during the motion cycle, determine:

- 1 Speed at the start of the deceleration
- 2 Speed at the end of the deceleration
- 3 Time over which the deceleration takes place.

### A.1.3: Calculate Energy Returned for Each Deceleration

Use the following formulas to calculate the energy returned during each deceleration:

#### Rotary motor:

$$E_{\text{dec}} = \frac{1}{2} J_t (\omega_1^2 - \omega_2^2)$$

Where:

$E_{\text{dec}}$  = Energy returned by the deceleration, in Joules.

$J_t$  = Load inertia on the motor shaft plus the motor inertia in kg m<sup>2</sup>.

$\omega_1$  = Shaft speed at the start of deceleration in radians per second.

$\omega_2$  = Shaft speed at the end of deceleration in radians per second.

$\omega$  =  $2 * \pi * (\text{RPM} / 60)$

#### Linear motor:

$$E_{\text{dec}} = \frac{1}{2} M_t (V_1^2 - V_2^2)$$

Where:

$E_{\text{dec}}$  = Energy returned by the deceleration, in Joules.

$M_t$  = Total mass of the load and the moving part of the motor in kg.

$V_1$  = Velocity at the start of deceleration in meters per second.

$V_2$  = Velocity at the end of deceleration in meters per second.

### A.1.4: Determine the Amount of Energy Dissipated by the Motor

Calculate the amount of energy dissipated by the motor due to current flow through the motor winding resistance using the following formulas.

$$P_{\text{motor}} = \frac{3}{4} R_{\text{winding}} (F / Kt)^2$$

Where:

$P_{\text{motor}}$  = Power dissipated in the motor in Watts.

$R_{\text{winding}}$  = Line to line resistance of the motor.

F = Force needed to decelerate the motor:

Nm for rotary applications

N for linear applications

Kt = Torque constant for the motor:

Nm/Amp for rotary applications

N/Amp for linear applications

$$E_{\text{motor}} = P_{\text{motor}} T_{\text{decel}}$$

Where:

$E_{\text{motor}}$  = Energy dissipated in the motor in Joules

$T_{\text{decel}}$  = Time of deceleration in seconds

### A.1.5: Determine the Amount of Energy Returned to the Drive

Calculate the amount of energy that will be returned to the drive for each deceleration using the following formula.

$$E_{\text{returned}} = E_{\text{dec}} - E_{\text{motor}}$$

Where:

$E_{\text{returned}}$  = Energy returned to the drive, in Joules

$E_{\text{dec}}$  = Energy returned by the deceleration, in Joules

$E_{\text{motor}}$  = Energy dissipated by the motor, in Joules

### A.1.6: Determine if Energy Returned Exceeds Drive Capacity

Compare the amount of energy returned to the drive in each deceleration with the drive's energy absorption capacity. For related drive specifications, see [Regen Circuit Output \(p. 67\)](#).

For mains voltages not listed in the specification table, use the following formula to determine the energy that can be absorbed by the drive.

$$W_{\text{capacity}} = \frac{1}{2} C (V_{\text{regen}}^2 - (1.414 V_{\text{mains}})^2)$$

Where:

$W_{\text{capacity}}$  = The energy that can be absorbed by the bus capacitors, in Joules.

$C$  = Bus capacitance in Farads.

$V_{\text{regen}}$  = Voltage at which the regen circuit turns on, in volts.

$V_{\text{mains}}$  = Mains voltage applied to the drive, in volts AC.

### A.1.7: Calculate Energy to be Dissipated for Each Deceleration

For each deceleration where the energy exceeds the drive's capacity, use the following formula to calculate the energy that must be dissipated by the regen resistor:

$$E_{\text{regen}} = E_{\text{returned}} - E_{\text{amp}}$$

Where:

$E_{\text{regen}}$  = Energy that must be dissipated in the regen resistor, in Joules.

$E_{\text{returned}}$  = Energy delivered back to the drive from the motor, in Joules.

$E_{\text{amp}}$  = Energy that the drive will absorb, in Joules.

### A.1.8: Calculate Pulse Power of Each Deceleration that Exceeds Drive Capacity

For each deceleration where energy must be dissipated by the regen resistor, use the following formula to calculate the pulse power that will be dissipated by the regen resistor:

$$P_{\text{pulse}} = E_{\text{regen}} / T_{\text{decel}}$$

Where:

$P_{\text{pulse}}$  = Pulse power in Watts.

$E_{\text{regen}}$  = Energy that must be dissipated in the regen resistor, in Joules.

$T_{\text{decel}}$  = Time of the deceleration in seconds.

### A.1.9: Calculate Resistance Needed to Dissipate the Pulse Power

Using the maximum pulse power from the previous calculation, calculate the resistance value of the regen resistor required to dissipate the maximum pulse power: For related drive specifications, see [Regen Circuit Output \(p. 67\)](#).

$$R = V_{\text{regen}}^2 / P_{\text{pulse max}}$$

Where:

$R$  = Resistance in Ohms.

$P_{\text{pulse max}}$  = The maximum pulse power.

$V_{\text{regen}}$  = The voltage at which the regen circuit turns on.

Choose a standard value of resistance less than the calculated value. This value must be greater than the minimum regen resistor value specified in [Regen Circuit Output \(p. 67\)](#).

### A.1.10: Calculate Continuous Power to be Dissipated

Use the following formula to calculate the continuous power that must be dissipated by the regen resistor. Use each deceleration where energy is dissipated by the regen resistor.

$$P_{\text{cont}} = (E_{\text{regen } 1} + E_{\text{regen } 2} + E_{\text{regen } \dots}) / T_{\text{cycle}}$$

Where:

$P_{\text{cont}}$  = The continuous power that will be dissipated by the resistor in Watts.

$E_{\text{regen } n}$  = Energy being dissipated during decelerations, in Joules.

$T_{\text{cycle}}$  = Total cycle time in seconds.

Choose a resistor with a power rating equal to or greater than the calculated continuous power. Verify that the calculated power value is less than the continuous regen power rating specified in [Regen Circuit Output \(p. 67\)](#).

### A.1.11: Select Fuses

For custom regen resistors, Cooper Bussman KLM fuses, or equivalent, should be selected. The peak and continuous currents, as well as the peak current time, must be taken into consideration for proper fuse selection. The duration of the peak current is the deceleration time ( $T_{\text{decel}}$ ) associated with the maximum pulse power regen event.

Use the following formulas to determine the minimum peak and continuous current ratings of the fuse. For related drive specifications, see [Regen Circuit Output \(p. 67\)](#).

The peak current is determined by the chosen regen resistor value.

$$I_{\text{peak}} = V_{\text{regen}} / R_{\text{regen}}$$

Where:

$I_{\text{peak}}$  = The current through the regen resistor during regeneration in Amps.

$V_{\text{regen}}$  = The voltage at which the regen circuit turns on.

$R_{\text{regen}}$  = The resistance value of the chosen regen resistor in Ohms.

The continuous current is determined by the continuous regen power.

$$I_{\text{cont}} = P_{\text{cont}} / V_{\text{regen}}$$

Where:

$I_{\text{cont}}$  = The minimum continuous current rating the fuse requires in Amps.

$P_{\text{cont}}$  = The continuous power calculated in the previous step, in Watts.

$V_{\text{regen}}$  = The voltage at which the regen circuit turns on.



# APPENDIX

## B: I<sup>2</sup>T TIME LIMIT ALGORITHM

The current loop I<sup>2</sup>T limit specifies the maximum amount of time that the peak current can be applied to the motor before it must be reduced to the continuous limit or generate a fault. This chapter describes the algorithm used to implement the I<sup>2</sup>T limit. Contents Include:

B.1: I<sup>2</sup>T Algorithm..... 138

## B.1: I<sup>2</sup>T Algorithm

### B.1.1: I<sup>2</sup>T Overview

The I<sup>2</sup>T current limit algorithm continuously monitors the energy being delivered to the motor using the I<sup>2</sup>T Accumulator Variable. The value stored in the I<sup>2</sup>T Accumulator Variable is compared with the I<sup>2</sup>T setpoint that is calculated from the user-entered Peak Current Limit, I<sup>2</sup>T Time Limit, and Continuous Current Limit. Whenever the energy delivered to the motor exceeds the I<sup>2</sup>T setpoint, the algorithm protects the motor by limiting the output current or generates a fault.

### B.1.2: I<sup>2</sup>T Formulas and Algorithm Operation

#### Calculating the I<sup>2</sup>T Setpoint Value

The I<sup>2</sup>T setpoint value has units of Amperes<sup>2</sup>-seconds (A<sup>2</sup>S) and is calculated from programmed motor data. The setpoint is calculated from the Peak Current Limit, the I<sup>2</sup>T Time Limit, and the Continuous Current Limit as follows:

$$\text{I}^2\text{T setpoint} = (\text{Peak Current Limit}^2 - \text{Continuous Current Limit}^2) * \text{I}^2\text{T Time Limit}$$

#### I<sup>2</sup>T Algorithm Operation

During drive operation, the I<sup>2</sup>T algorithm periodically updates the I<sup>2</sup>T Accumulator Variable at a rate related to the output current Sampling Frequency. The value of the I<sup>2</sup>T Accumulator Variable is incrementally increased for output currents greater than the Continuous Current Limit and is incrementally decreased for output currents less than the Continuous Current Limit. The I<sup>2</sup>T Accumulator Variable is not allowed to have a value less than zero and is initialized to zero upon reset or +24 Vdc logic supply power-cycle.

#### Accumulator Increment Formula

At each update, a new value for the I<sup>2</sup>T Accumulator Variable is calculated as follows:

$$\begin{aligned} \text{I}^2\text{T Accumulator Variable } n+1 = & \\ \text{I}^2\text{T Accumulator Variable } n & \\ +(\text{Actual Output Current } n+1^2 - \text{Continuous Current Limit}^2) * \text{Update period} & \end{aligned}$$

After each sample, the updated value of the I<sup>2</sup>T Accumulator Variable is compared with the I<sup>2</sup>T setpoint. If the I<sup>2</sup>T Accumulator Variable value is greater than the I<sup>2</sup>T Setpoint value, then the drive limits the output current to the Continuous Current Limit. When current limiting is active, the output current will be equal to the Continuous Current Limit if the commanded current is greater than the Continuous Current Limit. If instead the commanded current is less than or equal to the Continuous Current Limit, the output current will be equal to the commanded current.

### B.1.3: I<sup>2</sup>T Current Limit Algorithm – Application Example

#### I<sup>2</sup>T Example: Parameters

Operation of the I<sup>2</sup>T current limit algorithm is best understood through an example. For this example, a motor with the following characteristics is used:

- Peak Current Limit – 12 A
- I<sup>2</sup>T Time Limit – 1 S
- Continuous Current Limit – 6 A

From this information, the I<sup>2</sup>T setpoint is:

$$I^2T \text{ setpoint} = (12 A^2 - 6 A^2) * 1 S = 108 A^2S$$

See the example plot diagrams on the next page.

### I<sup>2</sup>T Example: Plot Diagrams

The plots that follow show the response of a drive (configured w/ I<sup>2</sup>T setpoint = 108 A<sup>2</sup>S) to a given current command. For this example, DC output currents are shown in order to simplify the waveforms. The algorithm essentially calculates the RMS value of the output current, and thus operates the same way regardless of the output current frequency and wave shape.

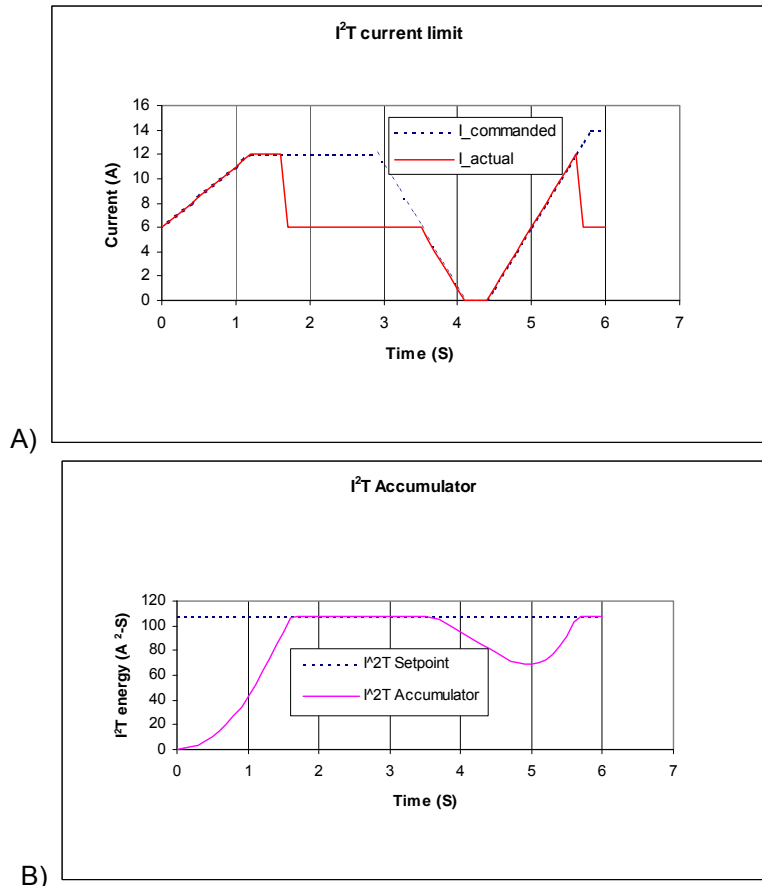

At time 0, plot diagram A shows that the actual output current follows the commanded current. Note that the current is higher than the continuous current limit setting of 6 A. Under this condition, the I<sup>2</sup>T Accumulator Variable begins increasing from its initial value of zero. Initially, the output current linearly increases from 6 A up to 12 A over the course of 1.2 seconds. During this same period, the I<sup>2</sup>T Accumulator Variable increases in a non-linear fashion because of its dependence on the square of the current.

At about 1.6 seconds, the I<sup>2</sup>T Accumulator Variable reaches a value equal to the I<sup>2</sup>T setpoint. At this time, the drive limits the output current to the continuous current limit even though the commanded current remains at 12 A. The I<sup>2</sup>T Accumulator Variable value remains constant during the next 2 seconds since the difference between the actual output current and the continuous current limit is zero.

At approximately 3.5 seconds, the commanded current falls below the continuous current limit and once again the output current follows the commanded current. Because the actual current is less than the continuous current, the I<sup>2</sup>T Accumulator Variable value begins to fall incrementally.

The I<sup>2</sup>T Accumulator Variable value continues to fall until at approximately 5.0 seconds when the commanded current goes above the continuous current limit again. The actual output current follows the current command until the I<sup>2</sup>T Accumulator Variable value reaches the I<sup>2</sup>T setpoint and current limiting is invoked.

# APPENDIX

## C: THERMAL CONSIDERATIONS

This chapter describes operating temperature characteristics, heatsink options, and heatsink mounting instructions. Contents include:

C.1: Operating Temperature and Cooling Configurations .....	142
C.2: Heatsink Mounting Instructions (XEL/XPL/XML).....	145

# C.1: Operating Temperature and Cooling Configurations

## C.1.1: XEL, XPL, and XML Models

The following charts show the maximum allowable ambient temperature of Xenus Plus drives for a variety of operating conditions and cooling configurations. The operating conditions considered cover a range of continuous output currents at both 120 Vac and 240 Vac mains voltages.

### Model XEL/XML/XPL-230-18 (-R) Mains 120 Vac

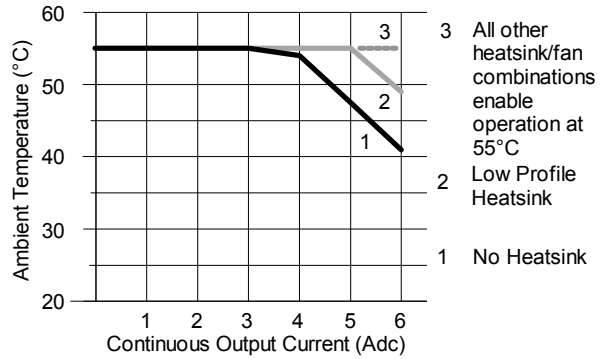
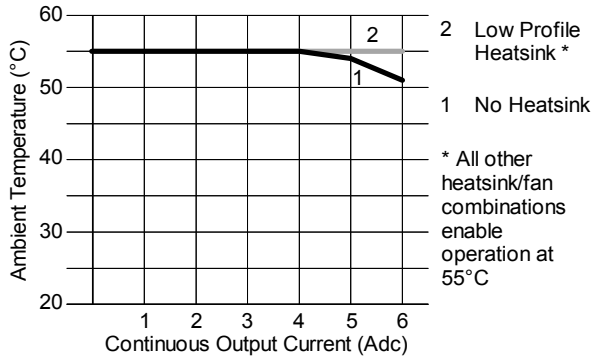

### Model XEL/XML/XPL-230-36 (-R)

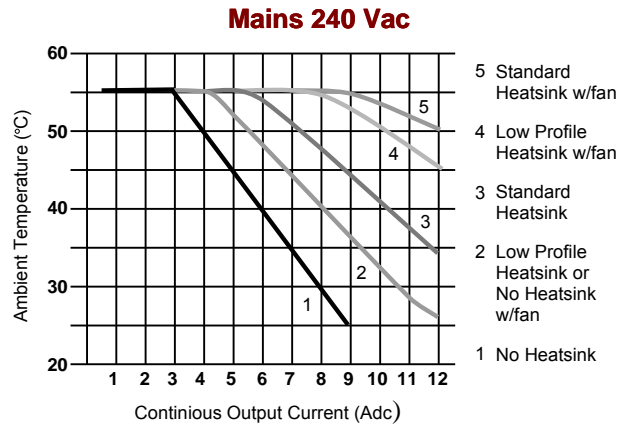
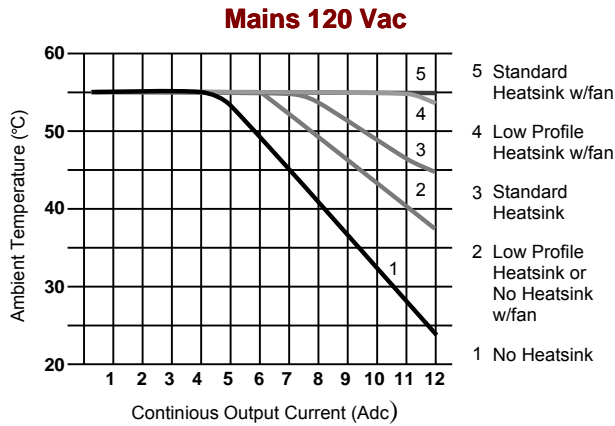

### Model XEL/XML/XPL-230-40 (-R)

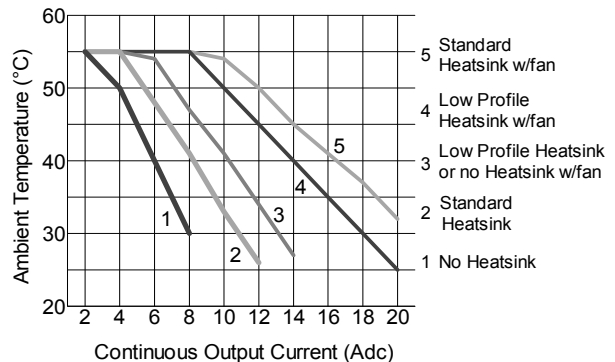
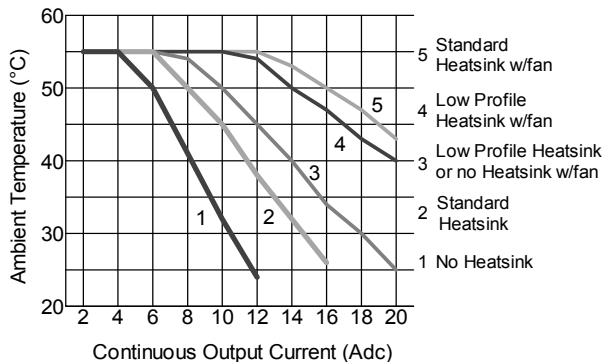

**C.1.2: XEL, XPL, and XML Heatsink and Fan Configurations**

**No Heatsink**

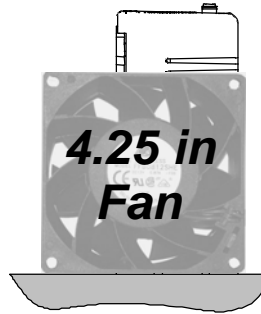
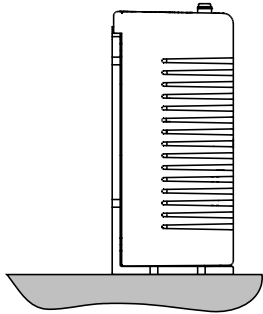

**Low-Profile Heatsink**

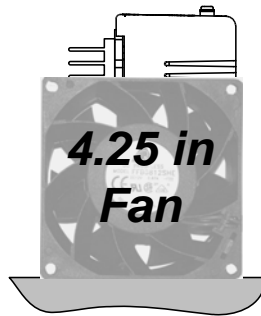
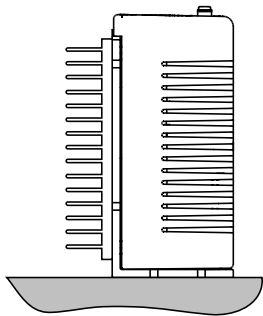

**Standard Heatsink**

**No Fan**

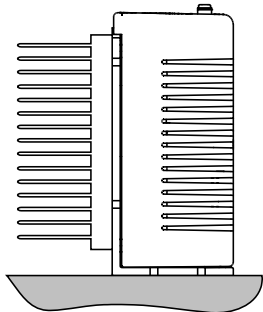

**With Fan\***

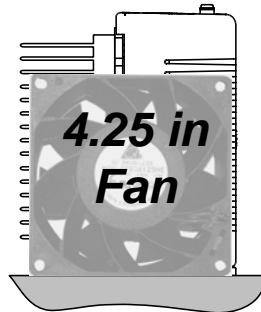

\* Select a 4.25-inch square fan that supplies forced air at a minimum rate of 300 linear feet per minute.

**C.1.3: XE2, XP2, XM2 and 800-1819 Models**

Due to the fan and heatsink integrated into their design, the XE2/XP2/XM2/800-1819 models are able to operate at full load conditions (both axes simultaneously) over the full specified operating range. Care must be taken in mounting the drives to ensure that airflow is not impeded. The heatsink/fan surface of the drive should be at least 1.5 in (38.1mm) from any other surface, including other drives, for adequate cooling.

**C.1.4: Model 800-1818**

The following chart shows the maximum allowable ambient temperature as a function of output current for the model 800-1818 drive. Data is given for two different mounting configurations with the drive operating from maximum rated mains input voltage.

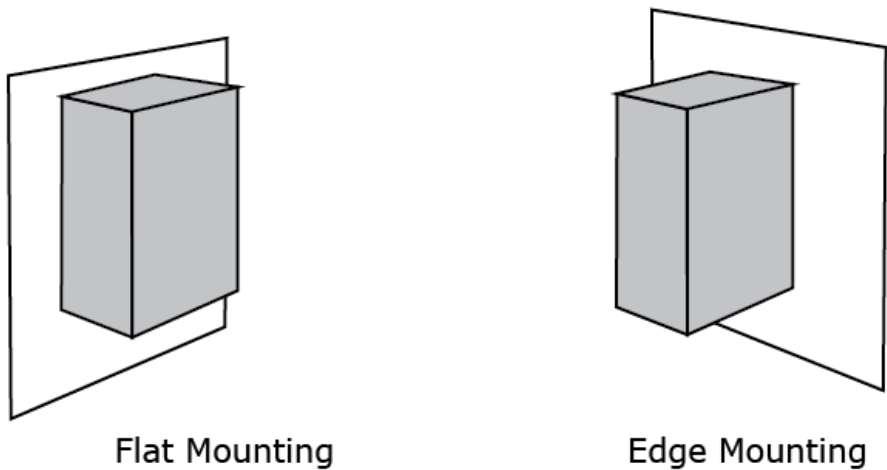
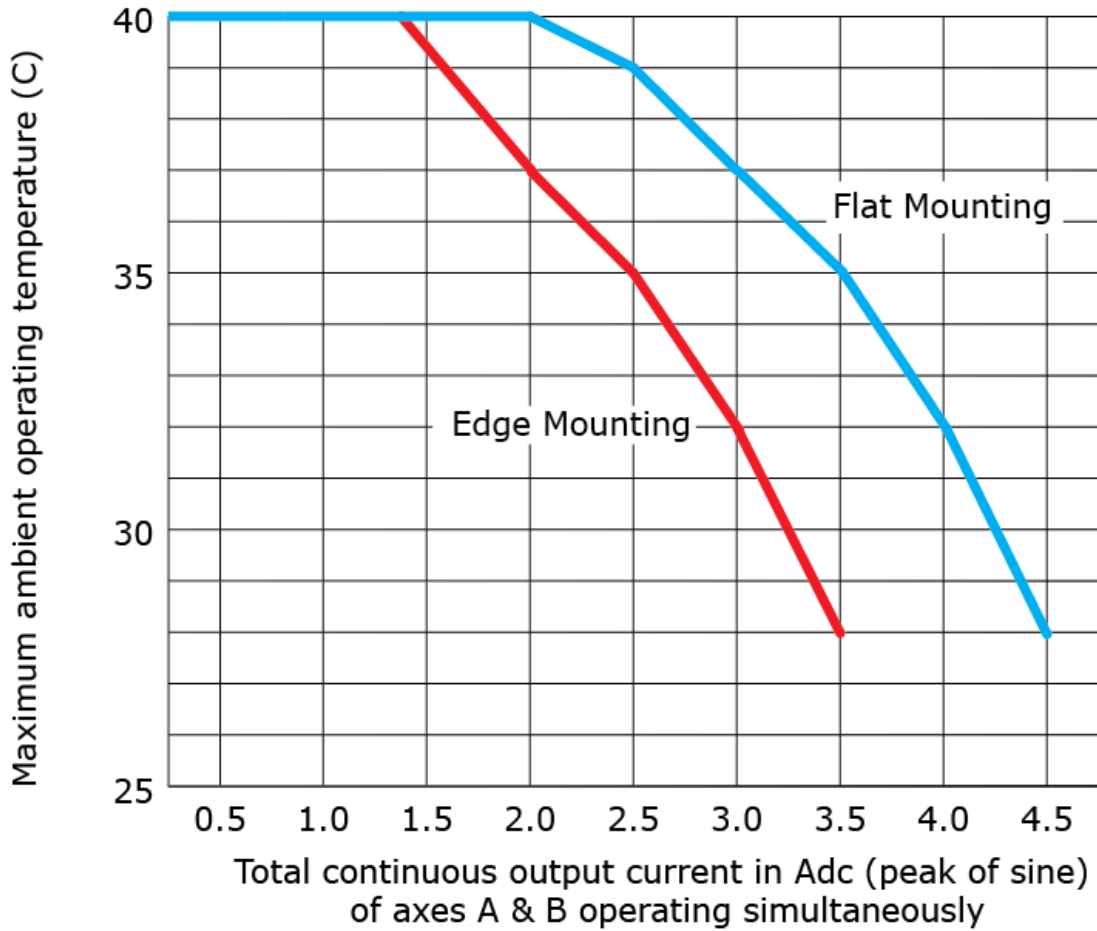



**C.2: Heatsink Mounting Instructions (XEL/XPL/XML)**

A dry film interface pad is used in place of thermal grease. The pad is die-cut to shape and has holes for the heat sink mounting screws. There are two protective sheets, blue on one side and clear on the other. Both must be removed when the interface pad is installed.

Remove the blue protective sheet from one side of the pad.

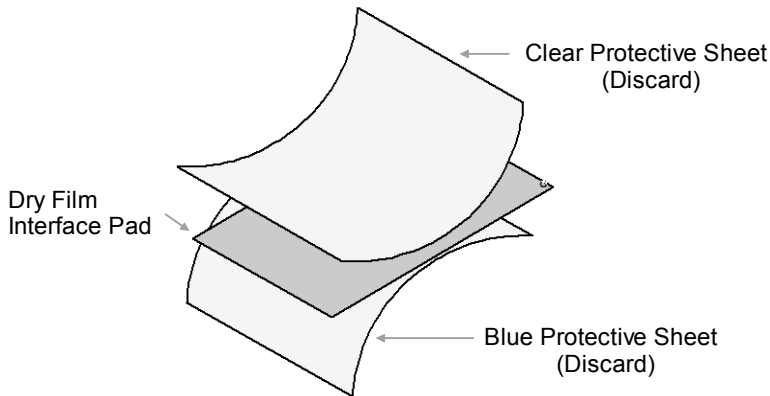

Place the interface pad on the drive, taking care to center the pad holes over the heatsink mounting holes.

Remove the clear protective sheet from the pad.

Mount the heatsink onto the drive taking care to see that the holes in the heatsink, interface pad, and drive all line up.

Torque the #8-32 mounting screws to 16~20 lb-in (1.8~2.3 Nm).

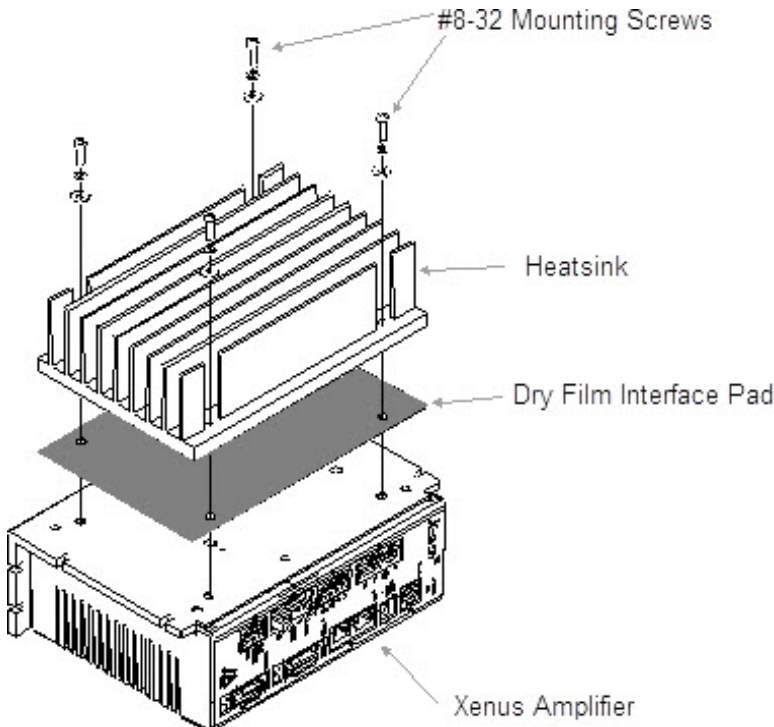

NOTE: The drawing shows the standard heatsink kit but the mounting instructions given are valid for the low profile heatsink kit as well.

# APPENDIX

## D: XENUS PLUS FILTER

This chapter provides an overview of the Model XTL-FA-01 edge filter. Contents include:

D.1: Overview .....	147
D.2: XTL-FA-01 Edge Filter Wiring .....	150

## D.1: Overview

The XTL-FA-01 edge filter can be used to minimize noise on the output of any Xenus Plus drive.

### D.1.1: Differential and Common Mode Filtering

Most noise is capacitively coupled from the motor power cable to neighboring cables. To minimize this noise, the XTL-FA-01 edge filter uses both differential edge filtering and common mode filtering. Differential edge filtering reduces the high frequency component of the PWM signal, thus producing a signal with less energy that can be coupled during transmission. Common mode filtering reduces the unnecessary common mode noise generated by PWM signals.

### D.1.2: Description and Functional Diagram

The differential filter increases the rise time by at least a factor of 3, substantially reducing noise in the system. Copley Controls drives typically have a 150 ns rise-time (high frequency component in the MHz range). Thus, the edge filter can increase rise time to 500 ns, reducing the high frequency noise emissions by the square law. The differential filter is designed with 82  $\mu\text{H}$  inductors and a proprietary passive circuit. The inductance will provide a total of 164  $\mu\text{H}$  in series with the load, helping to reduce ripple current. This brings low inductance motors into the required range.

The common mode filter is designed with a 220  $\mu\text{H}$  common mode toroid that works with the cable capacitance to earth ground to remove common mode switching noise.

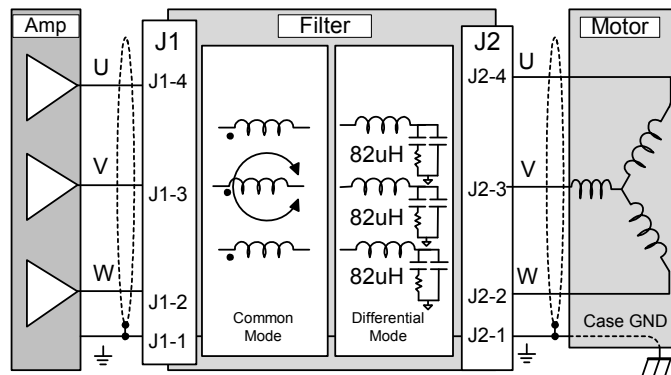

### D.1.3: PWM Output Plot

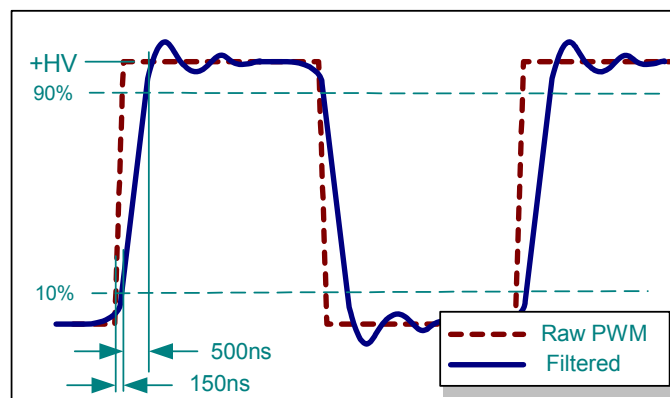

**D.1.3: XTL-FA-01 Edge Filter Specifications**

Input	Voltage, maximum	373 Vdc
	Current, maximum	20 Adc
Output	Voltage, maximum	373 Vdc
	Current, maximum	20 Adc
Peak Current/Peak Current Time		40 Adc for 1 second
Rise/Fall Time		500 ns (typical)
Differential Mode Inductance		82 $\mu$ H per phase, 162 $\mu$ H phase-phase (nominal)
Common Mode Inductance		220 $\mu$ H (nominal)
Nominal Resistance		27 milliohms per leg, 54 milliohms phase-phase (nominal)
Agency Approvals		UL508C, EN60204, RoHS
Weight		1 lb. 11 oz.

**D.1.4: Thermal Considerations**

**Cooling Requirements**

When used with XE2/XP2/XM2-230-20/800-1818/800-1819, XEL/XML/XPL-230-18 or XEL/XML/XPL-230-36 drives, the XTL-FA-01 operates below maximum temperature values, and thus requires no cooling fan.

When used with XEL/XML/XPL-40 drives running continuous currents greater than 12 Adc, the XTL-FA-01 should be cooled with an external fan. The fan should have a flow rate of at least 110 CFM. The filter has been tested using the Comair Rotron MD24B2 24 Vdc powered fan.

**Fan Mounting Guidelines**

Most of the filter’s heat is transferred to ambient air, rather than through the heat plate. Thus, it is very important to mount the filter and fan in such a way that the fan can blow up through the filter’s cover slots. Mount the filter on edge and mount the fan below it so that it blows up through the cover slots.

There is no heatsink option for the XTL-FA-01 edge filter.

**D.1.5: XTL-FA-01 Edge Filter Dimensions**

The following diagram shows the mounting dimensions of the XTL-FA-01 Edge Filter.

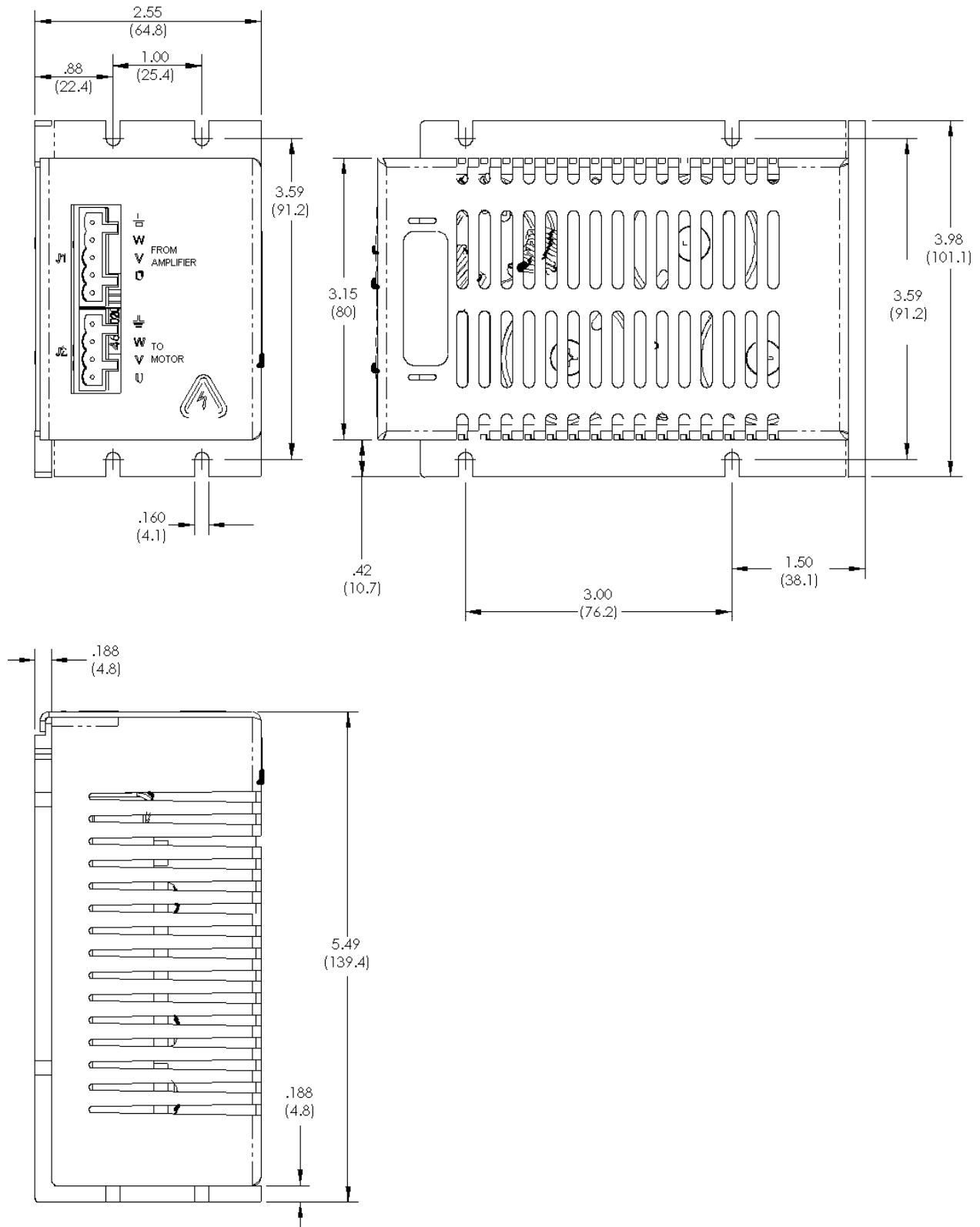



## D.2: XTL-FA-01 Edge Filter Wiring

This section describes the wiring of the XTL-FA-01 Edge Filter.

### D.2.1: Electrical Codes and Warnings

Be sure that all wiring complies with the National Electrical Code (NEC) or its national equivalent, and all prevailing local codes.

 <b>DANGER</b>	<p><b>DANGER: Hazardous voltages.</b></p> <p>Exercise caution when installing.  <b>Failure to heed this warning can cause equipment damage, injury, or death.</b></p>
 <b>DANGER</b>	<p><b>Risk of electric shock.</b></p> <p>High-voltage circuits on Xenus Plus J1, J2, and J3 and on Filter J1 and J2 are connected to mains power.  <b>Failure to heed this warning can cause equipment damage, injury, or death.</b></p>
 <b>WARNING</b>	<p><b>Do not ground mains-connected circuits.</b></p> <p>With the exception of the ground pins on Xenus Plus J1, J2, and J3 and on Filter J1 and J2, all of the other circuits on these connectors are mains-connected and must never be grounded.  <b>Failure to heed this warning can cause equipment damage.</b></p>

**D.2.2: Connector Locations**

Edge Filter J1 connects to Xenus Plus J2 (J3 or J4 for XE2/XP2/XM2/800-1818/800-1819).  
Edge Filter J2 connects to the motor.



**D.2.3: Cable Notes**

- 1 Keep the Edge Filter to Xenus Plus cable as short as possible. A typical length is 7 inches.
- 2 To reduce noise, twisted shielded cable must be used and the signal cables should not be bundled in the same conduit.

**D.2.4: Edge Filter Input (J1) From Drive**

**Mating Connector**

Description	Euro-style, 5 position, 5.0 mm pluggable female terminal block
Manufacturer PN	Wago 721-105/026-047 (Note 1)
Connector Wire Size	22-12 AWG
Recommended Wire	12 AWG, 600 V (Shielded cable used for CE compliance)
Wire Insertion/Extraction Tool	Wago 231-131
Connector and tool are included in Connector Kit XTL-FK.	

Note 1: For RoHS compliance, append "/RN01-0000" to the Wago part numbers listed above.

**Pin Description**

Pin	Signal	Function
1	Frame Ground	Chassis ground and cable shield
2	Phase W	Phase W input from drive
3	Phase V	Phase V input from drive (use for DC motor connection)
4	Phase U	Phase U input from drive (use for DC motor connection)
5	---	No connection

**D.2.5: Edge Filter Output (J2) To Motor**

**Mating Connector**

Description	Euro-style, 4 position, 5.0 mm pluggable female terminal block.
Manufacturer PN	Wago: 721-104/026-047 (Note 1)
Connector Wire Size	22-12 AWG
Recommended Wire	12 AWG, 600 V (Shielded cable used for CE compliance)
Wire Insertion/Extraction Tool	Wago: 231-131
Connector and tool are included in Connector Kit XTL-FK.	

Note 1: For RoHS compliance, append "/RN01-0000" to the Wago part numbers listed above.

**Pin Description**

Pin	Signal	Function
1	Ground	Chassis ground and cable shield
2	Phase W	Phase W output to motor
3	Phase V	Phase V output to motor (use for DC motor connection)
4	Phase U	Phase U output to motor (use for DC motor connection)



**D.2.6: Diagram: Edge Filter Wiring with Brushless Motor**

This is an example for a Xenus Plus Single Axis drive. For Xenus Plus Dual Axis, connectors J3 or J4 on the drive are used for outputs to the filter.

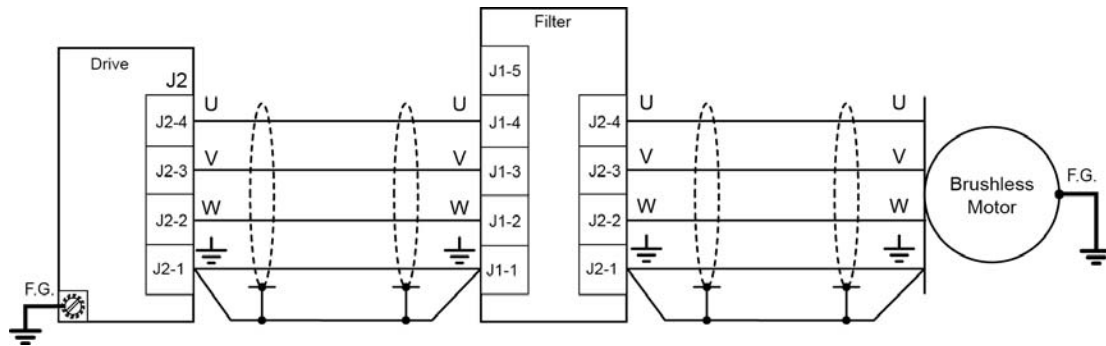

**D.2.7: Diagram: Edge Filter Wiring with Brush Motor**

This is an example for a Xenus Plus Single Axis drive. For Xenus Plus Dual Axis, connectors J3 or J4 on the drive are used for outputs to the filter.

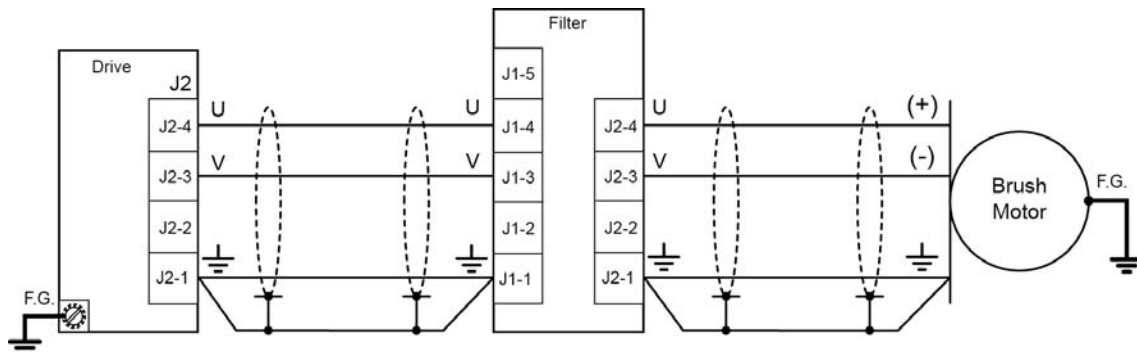

**D.2.8: XTL-FA-01 Edge Filter Ordering**

**Filter**

Model	Description
XTL-FA-01	Xenus Plus Edge Filter

**Connector Kit**

Model	Qty	Ref	Description	Mfr. Model No.
XTL-FK	1	J1	Plug, 5 position, 5.0 mm, female	Wago: 721-105/026-047
	1	J2	Plug, 4 position, 5.0 mm, female	Wago: 721-104/026-047
	2	--	Insertion / Extraction Tool	Wago: 231-131

Note 1: For RoHS compliance, append "/RN01-0000" to the Wago part numbers listed above.

# APPENDIX

## E: CONNECTING XPL/XP2 FOR SERIAL CONTROL

This chapter describes how to connect one or more XPL/XP2 drives for control via the RS-232 bus on one of the drives. Contents Include:

E.1: Single-Axis and Multi-Drop ..... 154

## E.1: Single-Axis and Multi-Drop

An XPL/XP2 drive's RS-232 serial bus can be used by CME 2 for drive commissioning. The serial bus can also be used by an external control application (HMI, PLC, PC, etc.) for setup and direct serial control of the drive. The control application can issue commands in ASCII format.

For experimentation and simple setup and control, a telnet device such as the standard Microsoft Windows HyperTerminal can also be used to send commands in ASCII format. For more information, see Copley Controls ASCII RS-232 User Guide.

The serially connected drive can also be used as a multi-drop gateway for access to other drives linked in a series of CAN bus connections.

Instructions for hooking up a single-axis connection and a multi-drop network appear below.

### E.1.2: Single-Axis Connections

For RS-232 serial bus control of a single axis, set the CAN node address of that axis drive to zero (0). Note that if the CAN node address is switched to zero after power-up, the drive must be reset or power cycled to make the new address setting take effect.

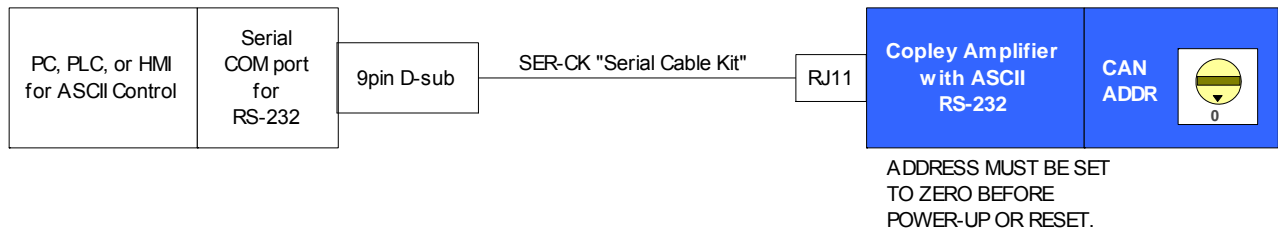

### E.1.3: Multi-Drop Network Connections

A serially connected XPL/XP2 drive can be used as a multi-drop gateway for access to other XPL/XP2 drives linked in a series of CAN bus connections. Set the CAN node address of the serially connected drive (gateway) to zero (0). Assign each additional drive in the chain a unique CAN node address value between 1 and 127. If the XP2 is used as the master, axis B is sequentially addressed automatically. Also, when using XP2 as a master, axis A will not be available for CAN controls. Use 120 Ohms termination on the first and last drive.

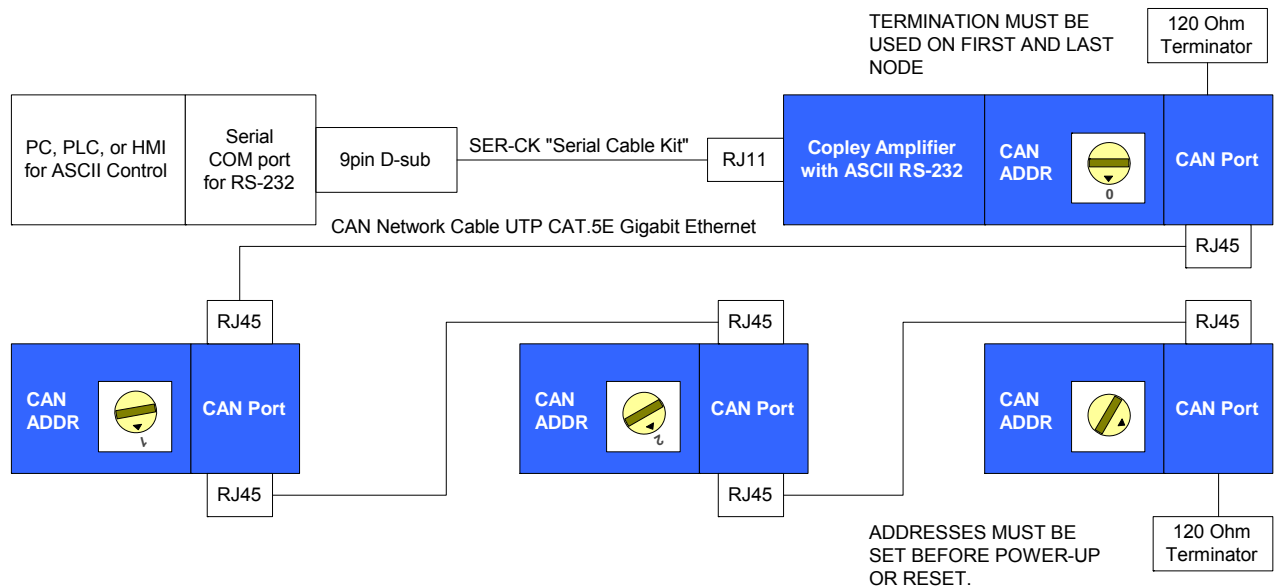

# APPENDIX

## F: ORDERING GUIDE AND ACCESSORIES

This chapter lists part numbers for drives and accessories. Contents include:

F.1: Drive Model Numbers .....	157
F.2: Accessory Model Numbers.....	160
F.3: Heatsink Kits.....	161
F.4: Regen Resistor Assemblies .....	162
F.5: Edge Filter .....	162
F.6: Order Example .....	162
F.7: Copley Standard Regen Resistor Specifications.....	163

## F.1: Drive Model Numbers

### XEL

Model Number	Description
XEL-230-18	Xenus Plus EtherCAT Servo drive 6/18 A
XEL-230-18-HL	Xenus Plus EtherCAT Servo drive 6/18 A with factory-fitted, low-profile heatsink
XEL-230-18-HS	Xenus Plus EtherCAT Servo drive 6/18 A with factory-fitted, standard heatsink
XEL-230-36	Xenus Plus EtherCAT Servo drive 12/36 A
XEL-230-36-HL	Xenus Plus EtherCAT Servo drive 12/36 A with factory-fitted, low-profile heatsink
XEL-230-36-HS	Xenus Plus EtherCAT Servo drive 12/36 A with factory-fitted, standard heatsink
XEL-230-40	Xenus Plus EtherCAT Servo drive 20/40 A
XEL-230-40-HL	Xenus Plus EtherCAT Servo drive 20/40 A with factory-fitted, low-profile heatsink
XEL-230-40-HS	Xenus Plus EtherCAT Servo drive 20/40 A with factory-fitted, standard heatsink
XEL-230-18-R	Xenus Plus EtherCAT Servo drive 6/18 A with resolver feedback
XEL-230-18-R-HL	Xenus Plus EtherCAT Servo drive 6/18 A with resolver feedback and factory-fitted, low-profile heatsink
XEL-230-18-R-HS	Xenus Plus EtherCAT Servo drive 6/18 A with resolver feedback and factory-fitted, standard heatsink
XEL-230-36-R	Xenus Plus EtherCAT Servo drive 12/36 A with resolver feedback
XEL-230-36-R-HL	Xenus Plus EtherCAT Servo drive 12/36 A with resolver feedback and factory-fitted, low-profile heatsink
XEL-230-36-R-HS	Xenus Plus EtherCAT Servo drive 12/36 A with resolver feedback and factory-fitted, standard heatsink
XEL-230-40-R	Xenus Plus EtherCAT Servo drive 20/40 A with resolver feedback
XEL-230-40-R-HL	Xenus Plus EtherCAT Servo drive 20/40 A with resolver feedback and factory-fitted, low-profile heatsink
XEL-230-40-R-HS	Xenus Plus EtherCAT Servo drive 20/40 A with resolver feedback and factory-fitted, standard heatsink

NOTE: Heatsink kits for field installation may be ordered separately.

### XE2

Model Number	Description
XE2-230-20	Xenus Plus 2-Axis EtherCAT Servo drive 10/20 A, encoder feedback
XE2-230-20-R	Xenus Plus 2-Axis EtherCAT Servo drive 10/20 A, resolver feedback
800-1818	Xenus Plus 2-Axis EtherCAT Servo drive 4.5/9 A, encoder feedback
800-1819	Custom Xenus Plus 2-Axis EtherCAT Servo drive 10/20 A, resolver feedback

### XP2

Model Number	Description
XP2-230-20	Xenus Plus 2-Axis CANopen Servo drive 10/20 A, encoder feedback
XP2-230-20-R	Xenus Plus 2-Axis CANopen Servo drive 10/20 A, resolver feedback

**XPL**

<b>Model Number</b>	<b>Description</b>
XPL-230-18	Xenus Plus Standard Servo drive 6/18 A
XPL-230-18-HL	Xenus Plus Standard Servo drive 6/18 A with factory-fitted, low-profile heatsink
XPL-230-18-HS	Xenus Plus Standard Servo drive 6/18 A with factory-fitted, standard heatsink
XPL-230-36	Xenus Plus Standard Servo drive 12/36 A
XPL-230-36-HL	Xenus Plus Standard Servo drive 12/36 A with factory-fitted, low-profile heatsink
XPL-230-36-HS	Xenus Plus Standard Servo drive 12/36 A with factory-fitted, standard heatsink
XPL-230-40	Xenus Plus Standard Servo drive 20/40 A
XPL-230-40-HL	Xenus Plus Standard Servo drive 20/40 A with factory-fitted, low-profile heatsink
XPL-230-40-HS	Xenus Plus Standard Servo drive 20/40 A with factory-fitted, standard heatsink
XPL-230-18-R	Xenus Plus Standard Servo drive 6/18 A with resolver feedback
XPL-230-18-R-HL	Xenus Plus Standard Servo drive 6/18 A with resolver feedback and factory-fitted, low-profile heatsink
XPL-230-18-R-HS	Xenus Plus Standard Servo drive 6/18 A with resolver feedback and factory-fitted, standard heatsink
XPL-230-36-R	Xenus Plus Standard Servo drive 12/36 A with resolver feedback
XPL-230-36-R-HL	Xenus Plus Standard Servo drive 12/36 A with resolver feedback and factory-fitted, low-profile heatsink
XPL-230-36-R-HS	Xenus Plus Standard Servo drive 12/36 A with resolver feedback and factory-fitted, standard heatsink
XPL-230-40-R	Xenus Plus Standard Servo drive 20/40 A with resolver feedback
XPL-230-40-R-HL	Xenus Plus Standard Servo drive 20/40 A with resolver feedback and factory-fitted, low-profile heatsink
XPL-230-40-R-HS	Xenus Plus Standard Servo drive 20/40 A with resolver feedback and factory-fitted, standard heatsink
NOTE: NOTE: Heatsink kits for field installation may be ordered separately.	

**XML**

<b>Model Number</b>	<b>Description</b>
XML-230-18	Xenus Plus MACRO Servo drive 6/18 A
XML-230-18-HL	Xenus Plus MACRO Servo drive 6/18 A with factory-fitted, low-profile heatsink
XML-230-18-HS	Xenus Plus MACRO Servo drive 6/18 A with factory-fitted, standard heatsink
XML-230-36	Xenus Plus MACRO Servo drive 12/36 A
XML-230-36-HL	Xenus Plus MACRO Servo drive 12/36 A with factory-fitted, low-profile heatsink
XML-230-36-HS	Xenus Plus MACRO Servo drive 12/36 A with factory-fitted, standard heatsink
XML-230-40	Xenus Plus MACRO Servo drive 20/40 A
XML-230-40-HL	Xenus Plus MACRO Servo drive 20/40 A with factory-fitted, low-profile heatsink
XML-230-40-HS	Xenus Plus MACRO Servo drive 20/40 A with factory-fitted, standard heatsink
XML-230-18-R	Xenus Plus MACRO Servo drive 6/18 A with resolver feedback
XML-230-18-R-HL	Xenus Plus MACRO Servo drive 6/18 A with resolver feedback and factory-fitted, low-profile heatsink
XML-230-18-R-HS	Xenus Plus MACRO Servo drive 6/18 A with resolver feedback and factory-fitted, standard heatsink
XML-230-36-R	Xenus Plus MACRO Servo drive 12/36 A with resolver feedback
XML-230-36-R-HL	Xenus Plus MACRO Servo drive 12/36 A with resolver feedback and factory-fitted, low-profile heatsink
XML-230-36-R-HS	Xenus Plus MACRO Servo drive 12/36 A with resolver feedback and factory-fitted, standard heatsink
XML-230-40-R	Xenus Plus MACRO Servo drive 20/40 A with resolver feedback
XML-230-40-R-HL	Xenus Plus MACRO Servo drive 20/40 A with resolver feedback and factory-fitted, low-profile heatsink
XML-230-40-R-HS	Xenus Plus MACRO Servo drive 20/40 A with resolver feedback and factory-fitted, standard heatsink
NOTE: Heatsink kits for field installation may be ordered separately.	

**XM2**

<b>Model Number</b>	<b>Description</b>
XM2-230-20	Xenus Plus 2-Axis MACRO Servo drive 10/20 A, encoder feedback
XM2-230-20-R	Xenus Plus 2-Axis MACRO Servo drive 10/20 A, resolver feedback

## F.2: Accessory Model Numbers

### Software

Model	Description
CME2	CME 2 Drive Configuration Software (Download)
CML	Copley Motion Libraries (Download, license required)
CMO	Copley Motion Objects (Download)
CPL	Copley Programming Language (Download, license required)

Links to these software releases can be found at: <http://www.copleycontrols.com/Motion/Downloads/index.html>

### Connector Kit with Solder-Cup Feedback and Control Connectors

#### XEL/XPL/XML

Model	Qty	Ref	Description	Mfr. Model No.
XEL-CK XPL-CK XML-CK Connector Kit	1	J1	Plug, 4 position, 7.5 mm, female	Wago: 721-204/026-045 (Note 1)
	1	J2	Plug, 4 position, 5.0 mm, female	Wago: 721-104/026-047 (Note 1)
	1	J3	Plug, 5 position, 5.0 mm, male	Wago: 721-605/000-044 (Note 1)
	1	J4	Plug, 3 position, 5.0 mm, female	Wago: 721-103/026-047 (Note 1)
	4	--	Tool, wire insertion and extraction	Wago: 231-131
	1	J5	Connector, D-Sub, 9-position, male, solder cup	Norcomp: 171-009-103L001
	1		Backshell, D-Sub, RoHS, metalized, for above	Norcomp: 979-009-020R121
	1	J8	Connector, high-density D-Sub, 26 position, female, solder cup	Norcomp: 180-026-203L001
	1		Backshell, D-Sub, RoHS, metalized, for above	Norcomp: 979-015-020R121
	1	J9	Connector, high-density D-Sub, 15 position, male, solder cup	Norcomp: 180-015-103L001
	1		Backshell, D-Sub, RoHS, metalized, for above	Norcomp: 979-009-020R121
	1	J10	Connector, High Density D-Sub Male 26 position, solder-cup	Norcomp: 180-026-103L001
	1		Backshell, D-Sub, RoHS, metalized, for above	Norcomp: 939-015-020R121

#### XE2/XP2/XM2/800-1818/800-1819

Model	Qty	Ref	Name	Description	Mfr. Model No.
XE2-CK Connector Kit	1	J1	AC Pwr	Plug, 5 position, 5.08 mm, female	Wago: 231-305/107-000 (Note 1)
	1	J2	Regen	Plug, 3 position, 5.08 mm, female	Wago: 231-303/107-000 (Note 1)
	2	J3, J4	Motor	Plug, 4 position, 5.08 mm, female	Wago: 231-304/107-000 (Note 1)
	1	J5	Brake	Plug, 5 position, 3.5 mm, female	Wago: 734-105/107-000 (Note 1)
	1	J5	Tool	Tool, wire insertion & extraction, 734 series	Wago: 734-191
	4	J1, J2 J3, J4	Tool	Tool, wire insertion & extraction, 231 series	Wago: 231-291
	1	J6 Note 2	Safety	Connector, DE-9M, 9-position, standard, male	AMP/Tyco: 205204-4
	9			AMPLIMITE HDP-20 Crimp-Snap Contacts, 24-20 AWG, Sel Au/Ni	AMP/Tyco: 66506-9
	1			Backshell, DE-9, RoHS, metallized, for J6	Norcomp: 979-009-020R121
	1	J12	Control	Connector, high-density DB-44M, 44 position, male, solder cup	Norcomp: 180-044-103L001
	1			Backshell, DB-44, 44 Pin, RoHS, metallized	Norcomp: 979-025-020R121
	2	J9	I/O	Connector, high-density DA-26F, 26 position, female, solder cup	Norcomp: 180-026-203L001
	2	J10~11	Feed-back	Connector, high-density DA-26M, 26 position, male, solder cup	Norcomp: 180-026-103L001
	3	J9~11		Backshell, DA-26, RoHS, metallized	Norcomp: 979-015-020R121
SER-CK	1	J7	RS-232	Serial Cable Kit	
XE2-NC-10	1	J8	Network	Ethercat <sup>®</sup> network cable, 10 ft (3 m)	
XE2-NC-01	1			Ethercat <sup>®</sup> network cable, 1 ft (0.3 m)	

Note 1: For RoHS compliance, append "/RN01-0000" to the Wago part numbers listed above.

Note 2: Insertion/extraction tool for J6 contacts is AMP/Tyco 91067-2 (not included in XP2-CK)



**CANopen Connector Kit (XPL/XP2)**

Model	Qty	Ref	Description
XPL-NK	1	J7	Sub-D 9-position female to RJ-45 adapter
	1	J7	CAN bus Network Cable, 10 ft (3 m)
	1		CAN bus RJ-45 Network Terminator

**Individual Cable Assemblies (and Related Accessories)**

Model	Ref	Description
SER-CK	J6	RS-232 Serial Cable Kit (for connecting PC to drive)
XPL-CV	J7	Sub-D 9-position female to RJ-45 adapter for XPL (PC to CANopen cable adapter)
XPL-NC-10	J7	CAN bus Network Cable for XPL, 10 ft (3 m)
XPL-NC-01		CAN bus Network Cable for XPL, 1 ft (0.3 m)
XPL-NT		CAN bus Network Terminator for XPL
XEL-NC-10	J7	EtherCAT Network Cable for XEL, 10 ft (3 m)
XEL-NC-01		EtherCAT Network Cable for XEL, 1 ft (0.3 m)
XP2-NC-10	J8	CANopen® network cable for XP2, 10 ft (3 m)
XP2-NC-01		CANopen® network cable for XP2, 1 ft (0.3 m)
XP2-NC-10	J8	CANopen® network cable for XP2, 10 ft (3 m)
XP2-NC-01		CANopen® network cable for XP2, 1 ft (0.3 m)

**F.3: Heatsink Kits**

XE2, XP2, XM2 models have integral heatsinks and cooling fans. The heatsink kits for XEL, XPL, XML models are optional and provide cooling when required by the installation.

**XEL/XPL/XML, Low Profile**

Model	Qty	Description
XEL-HL	1	Heatsink, low-profile
XPL-HL	1	Heatsink thermal material
XML-HL	1	Heatsink hardware mounting kit

**XEL/XPL/XML, Standard**

Model	Qty	Description
XEL-HS	1	Heatsink, standard
XPL-HS	1	Heatsink thermal material
XML-HS	1	Heatsink hardware mounting kit

These kits contain the parts needed for field installation of a heatsink.

## F.4: Regen Resistor Assemblies

Model	Description
XTL-RA-03	Regen Resistor Assembly (for use with XEL/XML/XPL-230-18)
XTL-RA-04	Regen Resistor Assembly (for use with XEL/XML/XPL-230-36, XEL/XML/XPL-230-40 and XE2/XP2/XM2-230-20/800-1819)

For more information, see Regen Resistor data sheet:

<http://www.copleycontrols.com/Motion/Downloads/xenusPlusData.html>

## F.5: Edge Filter

Model	Description
XTL-FA-01	Xenus Plus Edge Filter

### XTL-FA-01 Edge Filter Connector Kit (for all Xenus Plus models)

Model	Qty	Ref	Description	Mfr. Model No.
XTL-FK	1	J1	Plug, 5 position, 5.0 mm, female	Wago: 721-104/026-047
	1	J2	Plug, 4 position, 5.0 mm, female	Wago: 721-105/026-047
	2	--	Insertion / Extraction Tool	Wago 231-131

Note 1: For RoHS compliance, append "/RN01-0000" to the Wago part numbers listed above

## F.6: Order Example

Order 1 XEL-230-18 drive with standard heatsink fitted at the factory, Connector Kit, and serial

Qty	Item	Description
cable kit:		
1	XEL-230-18-HS	Xenus Plus EtherCAT Servo drive with standard heatsink installed
1	XEL-CK	Connector Kit with solder cup connectors
1	SER-CK	Serial Cable Kit for connecting the PC to the drive

## F.7: Copley Standard Regen Resistor Specifications

### F.7.1: Specifications

Specifications for Copley’s standard regen resistors are described below.

Model	Resistance	Default Continuous Power	Max Continuous Power	Peak Power	Peak Power Time	For Use With
XTL-RA-03	30 Ohms	65 W	400 W	5 kW	1000 ms	XEL/XML/XPL-230-18 XEL/XML/XPL-230-18-R
XTL-RA-04	15 Ohms	65 W	400 W	10 kW	1000 ms	XEL/XML/XPL-230-36 XEL/XML/XPL-230-36-R XEL/XML/XPL-230-40 XEL/XML/XPL-230-40-R XE2/XP2/XM2-230-20 800-1819 XE2/XP2/XM2-230-20-R



**WARNING**

#### High Temperature Risk.

Setting Default Continuous Power for a standard Copley regen resistor to a value greater than the default of 65 W may cause the resistor casing to heat to temperatures that could cause injury. If higher settings are required, contact Copley Controls customer support.

**Failure to heed this warning can cause equipment damage or injury.**

### F.7.2: Dimensions

The diagram below shows XTL-RA-03 and XTL-RA-04 mounting dimensions (in mm).

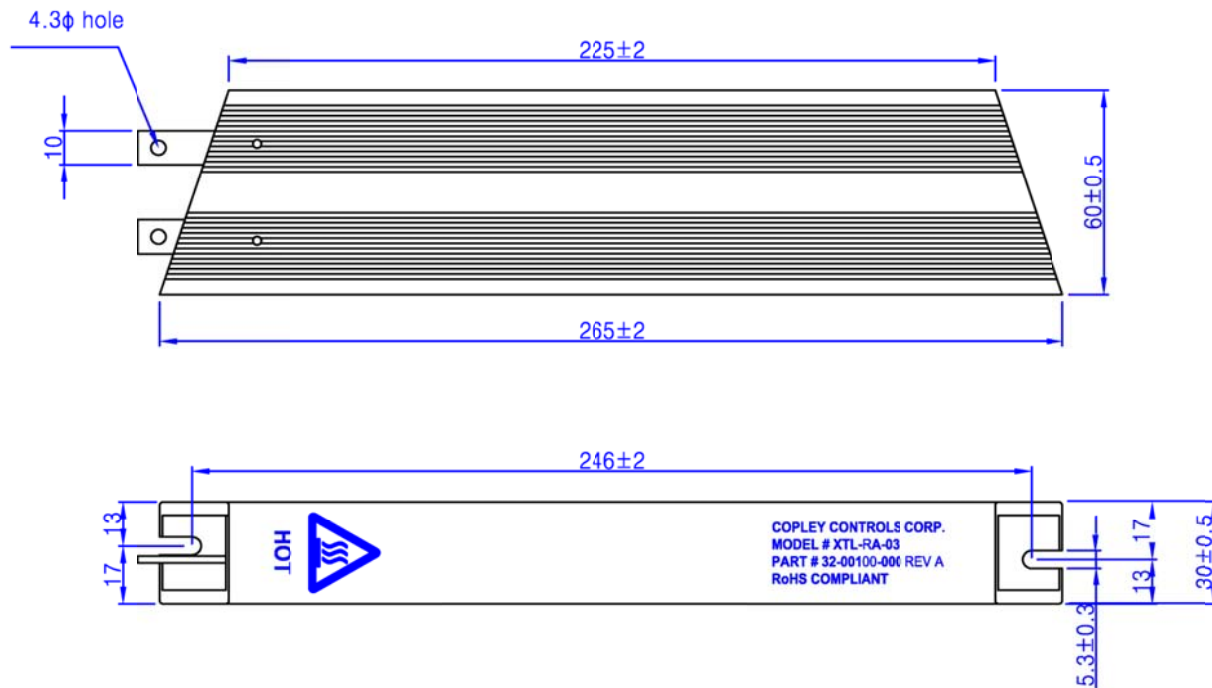

Xenus Plus User Guide

P/N 16-01344

Revision 01

April 2, 2015

© 2011, 2012, 2013, 2014, 2015

Copley Controls

Analogic Motion Controls

20 Dan Road

Canton, MA 02021 USA

All rights reserved